

Service Manual

Personal Computer

CF-T5

This is the Service Manual for
the following areas.
M ...for U.S.A. and Canada

Model No. CF-T5LWETZ1 2

1: Operation System

B: Microsoft® Windows® XP Professional

2: Area

M: Refer to above area table

 **WARNING**

This service information is designed for experienced repair technicians only and is not designed for use by the general public. It does not contain warnings or cautions to advise non-technical individuals of potential dangers in attempting to service a product. Products powered by electricity should be serviced or repaired only by experienced professional technicians. Any attempt to service or repair the product or products dealt with in this service information by anyone else could result in serious injury or death.

Panasonic®

© 2006 Matsushita Electric Industrial Co., Ltd. All rights reserved.
Unauthorized copying and distribution is a violation of law.

WARNINGS

For U.K.

This apparatus must be earthed for your safety.

To ensure safe operation the three-pin plug must be inserted only into a standard three-pin power point which is effectively earthed through the normal household wiring.

Extension cords used with the equipment must be three-core and be correctly wired to provide connection to earth. Wrongly wired extension cords are a major cause of fatalities.

The fact that the equipment operates satisfactorily does not imply that the power point is earthed and that the installation is completely safe.



For your safety, if you have any doubt about the effective earthing of the power point, consult a qualified electrician.

FOR YOUR SAFETY PLEASE READ THE FOLLOWING TEXT CAREFULLY

This appliance is supplied with a moulded three pin mains plug for your safety and convenience.

A 3 amp fuse is fitted in this plug.

Should the fuse need to be replaced please ensure that the replacement fuse has a rating of 3 amps and that it is approved by ASTA or BSI to BS 1362.

Check for the ASTA mark  or the BSI mark  on the body of the fuse.

If the plug contains a removable fuse cover you must ensure that it is refitted when the fuse is replaced.

If you lose the fuse cover the plug must not be used until a replacement cover is obtained.

A replacement fuse cover can be purchased from your local Panasonic Dealer.

IF THE FITTED MOULDED PLUG IS UNSUITABLE FOR THE SOCKET OUTLET IN YOUR HOME THEN THE FUSE SHOULD BE REMOVED AND THE PLUG CUT OFF AND DISPOSED OF SAFELY.

THERE IS A DANGER OF SEVERE ELECTRICAL SHOCK IF THE CUT OFF PLUG IS INSERTED INTO ANY 13 AMP SOCKET.

If a new plug is to be fitted please observe the wiring code as shown below.

If in any doubt please consult a qualified electrician.

Warning: THIS APPLIANCE MUST BE EARTHED.

Important

The wires in this mains lead are coloured in accordance with the following code:

Green-and-yellow: Earth

Blue: Neutral

Brown: Live

As the colours of the wires in the mains lead of this apparatus may not correspond with the coloured markings identifying the terminals in your plug, proceed as follows:

The wire which is coloured GREEN-and-YELLOW must be connected to the terminal in the plug which is marked by the letter E or by the safety earth symbol  coloured GREEN or GREEN-and-YELLOW.

The wire which is coloured Blue must be connected to the terminal which is marked with the letter N or coloured BLACK.

The wire which is coloured Brown must be connected to the terminal which is marked with the letter L or coloured RED.

The mains plug on this equipment must be used to disconnect the mains power.

Please ensure that a socket outlet is available near the equipment and shall be easily accessible.

How to replace the fuse

Open the fuse compartment with a screw-driver and replace the fuse.

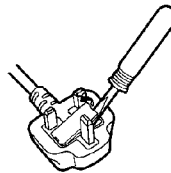

Warnings

- This equipment is not designed for connection to an IT power system.
(An IT system is a system having no direct connections between live parts and Earth; the exposed-conductive-parts of the electrical installation are earthed.
An IT system is not permitted where the computer is directly connected to public supply systems in the U.K.)
- Disconnect the mains plug from the supply socket when the computer is not in use.

This equipment is produced to BS800/1983.

Safety precautions

1. Before servicing, unplug the power cord to prevent an electric shock.
2. When replacing parts, use only manufacturer's recommended components for safety.
3. Check the condition of the power cord. Replace if wear or damage is evident.
4. After servicing, be sure to restore the lead dress, insulation barriers, insulation papers, shields, etc.

Important Safety Instructions

When using your telephone equipment, basic safety precautions should always be followed to reduce the risk of fire, electric shock and injury to persons, including the following:

1. Do not use this product near water, for example, near a bath tub, wash bowl, kitchen sink or laundry tub, in a wet basement or near a swimming pool.
2. Avoid using a telephone (other than a cordless type) during an electrical storm. There may be a remote risk of electric shock from lightning.
3. Do not use the telephone to report a gas leak in the vicinity of the leak.
4. Use only the power cord and batteries indicated in this manual. Do not dispose of batteries in a fire. They may explode. Check with local codes for possible special disposal instructions.

SAVE THESE INSTRUCTIONS

LITHIUM BATTERY ⚠

• **CAUTION**

Danger of explosion if battery is incorrectly replaced.
Replace only with the same or equivalent type recommended by the equipment manufacture.
Discard used batteries according to the manufacturer's instructions.

LITHIUMBATTERIES ⚠

Vorsicht!

Explosionsgefahr bei unsachgemäßem Austausch der Batterie. Ersatz nur durch denselben oder einen vom Hersteller empfohlenen ähnlichen Typ. Entsorgung gebrauchter Batterien nach Angaben des Herstellers.

PILE AU LITHIUM ⚠

ATTENTION: IL Y A DANGER D'EXPLOSION S' IL Y A REMPLACEMENT INCORRECT DE LA PILE. REMPLACER UNIQUEMENT AVEC UNE PILE DU MÊME TYPE OU D'UN TYPE RECOMMANDÉ PAR LE CONSTRUCTEUR. METTRE AU RÉBUT LES PILES USAGÉES CONFORMÉMENT AUX INSTRUCTIONS DU FABRICANT.

For U.S.A. / CANADA



A lithium ion battery that is recyclable powers the product you have purchased. Please call 1-800-8-BATTERY for information on how to recycle this battery.

L'appareil que vous vous êtes procuré est alimenté par une batterie au lithium-ion. Pour des renseignements sur le recyclage de la batterie, veuillez composer le 1-800-8-BATTERY.

Lithium Battery

Lithium Battery!

This computer contains a lithium battery to enable the date, time, and other data to be stored. The battery should only be exchanged by authorized service personnel.

Warning! A risk of explosion from incorrect installation or mis-application may possibly occur.

Precautions (Battery Pack)

- Care should be exercised with regard to the following in order to avoid the possibility of overheating, fire or damage.



Avoid Heat

Do not throw the battery pack into a fire or expose it to excessive heat.



Keep Articles Away

Do not place the battery pack together with articles such as necklaces or hairpins when carrying or storing.



Do Not Disassemble

Do not insert sharp objects into the battery pack, expose it to bumps or shocks, deform, disassemble, or modify it.



Do Not Short

Do not short the positive (+) and negative (-) contacts.



Avoid Extreme Heat, Cold and Direct Sunlight

Do not charge, use or leave the battery pack for extended periods where it will be exposed to direct sunlight, in a hot place (in an automobile on a sunny day, for example), or in a cold place.



Do Not Use With Any Other Computer

The battery pack is rechargeable and was intended for the specified computer or charger. Do not use it with a computer other than the one for which it was designed.



Do Not Put into a Microwave

Do not put the battery pack into a microwave oven or a pressurized chamber.



Discontinue Use

Should the battery emit an abnormal odor, become hot to the touch, become discolored, change shape, or become in any way different from normal, remove it from the computer or charger and discontinue use.

- Do not touch the terminals on the battery pack. The battery pack may no longer function properly if the contacts are dirty or damaged.
- Do not expose the battery pack to water, or allow it to become wet.

- If the battery pack will not be used for a long period of time (a month or more), charge or discharge (use) the battery pack until the remaining battery level becomes 30% to 40% and store it in a cool, dry place.
- This computer prevents overcharging of the battery by recharging only when the remaining power is less than approx. 95% of capacity.
- The battery pack is not charged when the computer is first purchased. Be sure to charge it before using it for the first time. When the AC adaptor is connected to the computer, charging begins automatically.
- Should the battery leak and the fluid get into your eyes, do not rub your eyes. Immediately flush your eyes with clear water and see a doctor for medical treatment as soon as possible.

NOTE

- The battery pack may become warm during recharging or normal use. This is completely normal.
- Recharging will not commence outside of the allowable temperature range (0 °C to 50 °C {32°F to 122 °F}). (☞ Reference Manual "Battery Power") Once the allowable range requirement is satisfied, charging begins automatically. Note that the recharging time varies based on the usage conditions. (Recharging takes longer than usual when the temperature is 10 °C {50 °F} or less.)
- If the temperature is low, the operating time is shortened. Only use the computer within the allowable temperature range.
- The battery pack is a consumable item. If the amount of time the computer can be run off a particular battery pack becomes dramatically shorter and repeated rechargings do not restore its performance, the battery pack should be replaced with a new one.
- When transporting spare batteries inside a package, briefcase, etc., it is recommended that it be placed in a plastic bag so that its contacts are protected.
- Always power off the computer when it is not in use. Leaving the computer on when the AC adaptor is not connected will exhaust the remaining battery capacity.

CONTENTS

1. Specifications	6
2. Names and Functions of Parts.....	8
3. Block Diagram	10
4. Diagnosis Procedure	11
5. Power-On Self Test (Boot Check).....	13
6. List of Error Codes <Only when the port replicator is connected>	14
7. Self Diagnosis Test	16
8. Wiring Connection Diagram	21
9. Disassembly/Reassembly	22
10. Exploded View	74
11. Replacement Parts List	78

1 Specifications

Main Specifications

Model No.		CF-T5LWETZBM	
CPU/ Secondary cache memory		Intel® Core™ Solo Processor Ultra Low Voltage U1400 (1.20 GHz, 2 MB* ¹ L2 cache, 533 MHz FSB)	
Chip Set		Mobile Intel® 945 GMS Express chip set	
Main Memory		512 MB* ¹ , DDR2 SDRAM (1536 MB* ¹ Max.)	
Video Memory		UMA (128 MB* ¹ Max.)* ²	
Hard Disk Drive		60 GB* ³	
Display Method		12.1 XGA type (TFT) (1024 × 768 dots)	
Internal LCD		65,536/16,777,216 colors (1024 × 768 dots)* ⁴	
External Display* ⁵		65,536/16,777,216 colors (800 × 600 dots/1024 × 768 dots/1280 × 768 dots/1280 × 1024 dots/1400 × 1050 dots/1600 × 1200 dots/2048 × 1536 dots (60 Hz)* ⁶)	
Simultaneous Display on LCD + External Display* ⁵		65,536/16,777,216 colors (800 × 600 dots, 1024 × 768 dots)* ⁴	
Wireless LAN		Intel® PRO/Wireless 3945 ABG Network Connection	
LAN* ⁷		IEEE 802.3 10Base-T, IEEE 802.3u 100Base-TX	
Modem		Data: 56 kbps (V.92) FAX: 14.4 kbps	
Sound		WAVE and MIDI playback, Intel® High Definition Audio subsystem support, Monaural Speaker (built in)	
Security Chip		TPM (TCG V1.2 compliant)* ⁸	
Card Slots	PC Card Slot	× 1, Type I or Type II, Allowable current 3.3 V: 400 mA, 5 V: 400 mA	
	SD Memory Card Slot* ⁹	× 1, Data transfer rate = 8 MB per second	
RAM Module Slot		× 1, DDR2 SDRAM, 172-pin, 1.8 V, Micro DIMM, PC2-4200 Compliant* ¹⁰	
Interface		USB Ports × 2 (USB2.0 × 2)* ¹¹ / Modem Port (RJ-11) / LAN Port (RJ-45) * ⁷ / External Display Port: Mini Dsub 15-pin female / Microphone Jack: Miniature jack, 3.5 DIA / Headphone Jack: Miniature jack, 3.5 DIA / Mini Port Replicator connector: Dedicated 50-pin male	
Keyboard/Pointing Device		83 keys/Touch Pad/Touchscreen (stylus (included) touch capable)	
Power Supply		AC adaptor or Battery pack	
AC Adaptor* ¹²		Input: 100 V - 240 V AC, 50 Hz/60 Hz Output: 16 V DC, 2.5 A	
Battery Pack		Li-ion 11.1 V, 7.65 Ah	
Operating Time* ¹³		Approx. 7 hours - 14 hours* ¹⁴ (Approx. 11 hours* ¹⁵) (Disable Economy Mode (ECO))	
Charging Time* ¹⁶		Approx. 5 hours (Power off)/Approx. 7 hours (Power on)	
Power Consumption* ¹⁷		Approx. 35 W* ¹⁸ / Approx. 40 W (maximum when recharging in the ON state)	
Physical Dimensions (W × H × D) (excluding the stylus holder)		<ul style="list-style-type: none"> • Including protrusion of the hand strap 268 mm × 33.3 mm (at the front)/71.1 mm (at the rear) × 218 mm {10.6 " × 1.3 " /2.8 " × 8.6 "} • Excluding protrusion of the hand strap 268 mm × 33.3 mm (at the front)/50.2 mm (at the rear) × 218 mm {10.6 " × 1.3 " /2.0 " × 8.6 "} 	
Weight* ¹⁹		Approx. 1600 g {3.5 lb.}	
Environment	Operation	Temperature	5°C to 35°C {41°F to 95°F}
		Humidity	30% to 80% RH (No condensation)
	Storage	Temperature	-20°C to 60°C {-4°F to 140°F}
		Humidity	30% to 90% RH (No condensation)
OS* ²⁰		Microsoft® Windows® XP Professional Service Pack 2 with Advanced Security Technologies (NTFS File system)	

Model No.	CF-T5LWETZBM
Pre-installed Software ^{*20}	Microsoft [®] Internet Explorer 6 Service Pack 2 / DirectX 9.0c / Microsoft [®] Windows [®] Media Player 10 / Microsoft [®] Windows [®] Movie Maker 2.1 / Microsoft [®] .NET Framework 1.1 SP1/2.0 / Adobe Reader / Intel [®] PROSet/Wireless Software <Only for models with wireless LAN> / SD Utility / Icon Enlarger / Loupe Utility / Touch Pad Utility / DMI Viewer / PC Information Viewer / Bluetooth™ Stack for Windows [®] by TOSHIBA <Only for model with Bluetooth> / Display Rotation Tool / Hotkey Settings / Wireless Switch Utility <Only for model with wireless LAN/wireless WAN/Bluetooth> / Economy Mode (ECO) Setting Utility / Battery Recalibration Utility / Infineon TPM Professional Package V2.5 ^{*21} / Recover Pro 6 ^{*21}
	Setup Utility / Hard Disk Data Erase Utility ^{*22} / PC-Diagnostic Utility ^{*23}

Wireless LAN <Only for model with wireless LAN>

Data Transfer Rates	IEEE802.11a: 54/48/36/24/18/12/9/6 Mbps (automatically switched) ^{*24} IEEE802.11b: 11/5.5/2/1 Mbps (automatically switched) ^{*24} IEEE802.11g: 54/48/36/24/18/12/9/6 Mbps (automatically switched) ^{*24}
Standard Supported	IEEE802.11a/IEEE802.11b/IEEE802.11g
Transmission Method	OFDM system, DS-SS system
Wireless Channels Used	IEEE802.11a: Channels 36/40/44/48/52/56/60/64/149/153/157/161/165 IEEE802.11b/ IEEE802.11g: Channels 1 to 11
RF Frequency Band	IEEE802.11a: 5.18 - 5.32 GHz, 5.745 - 5.825 GHz IEEE802.11b/ IEEE802.11g: 2412 - 2462 MHz

Bluetooth™ <Only for model with Bluetooth>

Bluetooth Version	2.0 + EDR
Transmission Method	FHSS system
Wireless Channels Used	Channels 1 to 79
RF Frequency Band	2.402-2.48 GHz
Power Class	Class 1

*1 1 MB = 1,048,576 bytes

*2 A segment of the main memory is allotted automatically depending on the computer's operating status. The size of the Video Memory cannot be set by the user.

*3 1 GB = 1,000,000,000 bytes. Your operating system or some application software will report as fewer GB.

*4 A 16,777,216 color display is achieved by using the dithering function.

*5 Display may be impossible using some connected external displays.

*6 When using an external display with a resolution of 2048 x 1536 dots, use a display that supports a 60Hz refresh rate. If an external display that does not support a 60Hz refresh rate is used, images may not be displayed properly.

*7 Some devices cannot be used depending on the port type.

*8 For information on TPM, click [start] - [Run] and input "c:\util\drivers\tpm\README.pdf", and refer to the Installation Manual of "Trusted Platform Module (TPM)".

*9 Operation has been tested and confirmed using Panasonic SD Memory Cards with a capacity of up to 2 GB. The transfer rate using the SD Memory Card slot on this computer is 8 MB per second. (This is a theoretical value, and differs from actual speeds.) The transfer rate is 8 MB per second even if you use an SD Memory Card that supports high-speed transfer rates. Operation on other SD equipment is not guaranteed. This computer is not compatible with MultiMediaCards or SDHC Memory Cards. Do not insert these kinds of cards.

*10 Only a RAM module designed for DDR2 (PC2-4200) can be added (Panasonic : CF-BAW0512U, CF-BAW1024U). JEDEC standard 214 pin Micro DIMM cannot be used. PC2100 / PC2700 172 pin Micro DIMM cannot be used.

If a PC2-3200 RAM module is installed, the main memory processing speed may become slower.

*11 Does not guarantee operation of all USB-compatible peripherals.

*12 <Only for North America>

The AC adaptor is compatible with power sources up to 240 V AC adaptor. This computer is supplied with a 125 V AC compatible AC cord.

20-M-2-1

*13 Varies depending on the usage conditions, or when an optional device is attached. Measured when the power saving function on the USB2.0 USB Root Hub is set to on. (At the time of purchase, the power saving function is activated.) When Economy Mode (ECO) is enabled, the operating time becomes approximately 20% shorter than when it is disabled.

*14 Measured using BatteryMark™ Version 4.0.1 (LCD brightness : Maximum - Minimum).

*15 Measured using MobileMark™ 2005 (LCD brightness : 60 cd/m²).

*16 Varies depending on the usage conditions, CPU speed, etc. It may take a long time to charge a fully discharged battery.

*17 Approx. 1.5 W when the battery pack is fully charged (or not being charged) and the computer is off.

*18 Rated power consumption.

23-E-1

*19 Average value. May differ depending on models.

*20 Operations of this computer are not guaranteed except for the pre-installed OS.

*21 Must be installed before use.

*22 The Product Recovery DVD-ROM is required.

*23 For startup methods, refer to "Hardware Diagnostics"

*24 These are speeds specified in IEEE802.11a+b+g standards. Actual speeds may differ.

2 Names and Functions of Parts

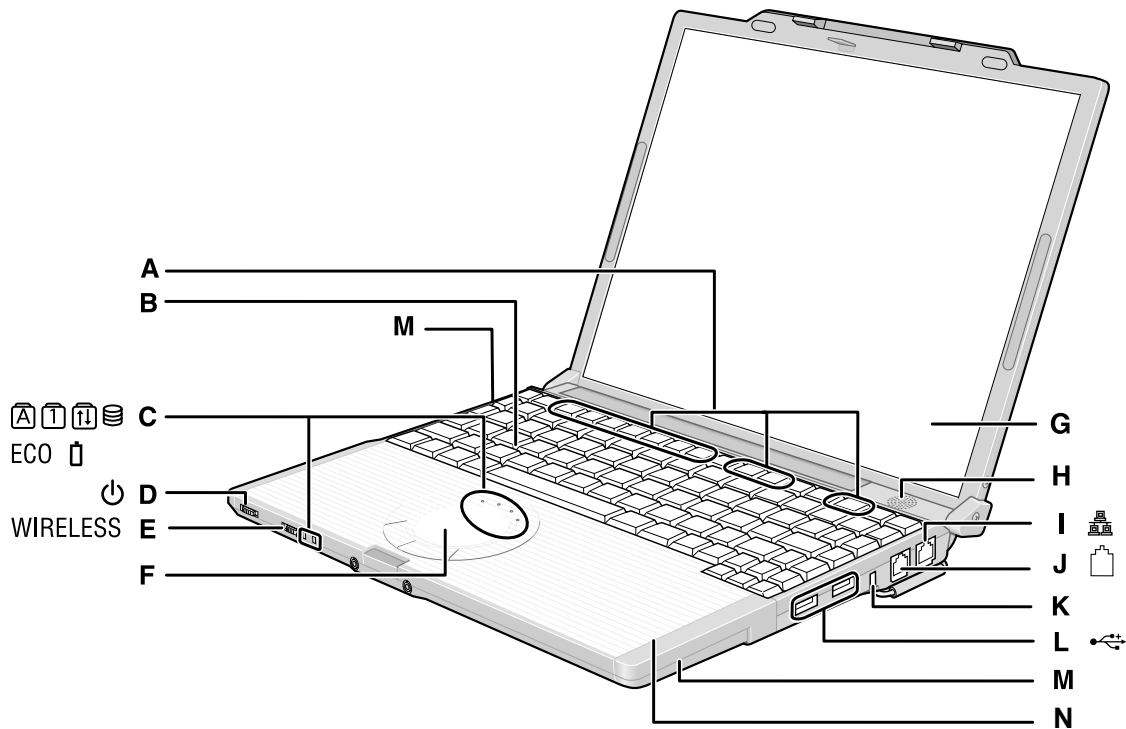

A : Function Key

B : Keyboard

C : LED Indicator

: Caps lock

: Numeric key (NumLk)

: Scroll lock (ScrLk)

: Hard disk drive status

ECO : Economy Mode (ECO) status

: Battery status

D : Power Switch

page 13

Power Indicator

Off: Power off/Hibernation

Green: Power on

Blinking green: Standby

E : Wireless Switch

<Only for model with wireless LAN/wireless WAN/
Bluetooth>

F : Touch Pad

G : LCD/Touchscreen

H : Speaker

I : LAN Port

If the Mini Port Replicator is connected to the computer, connect the LAN cable to the LAN port on the Mini Port Replicator. You cannot use the LAN port on the computer.

J : Modem Port

Be sure to use the included modem telephone cable, and insert the end of the cable with the phyllite core into the modem port on the computer.

K : Security Lock

You can connect a Kensington cable. Refer to the instruction manual of the cable. The security lock and cable is a theft prevention device. Matsushita Electric Industrial Co., Ltd. will bear no responsibility in the event of theft.

L : USB Ports

M : Wireless LAN Antenna

<Only for model with wireless LAN>

N : Bluetooth Antenna

<Only for model with Bluetooth>

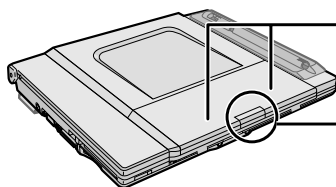

Wireless WAN Antenna

For model with EVDO or without wireless WAN:

The SIM card slot under this cover is not used for this model. Do not open the cover.

For other models:

Refer to the additional instructions.

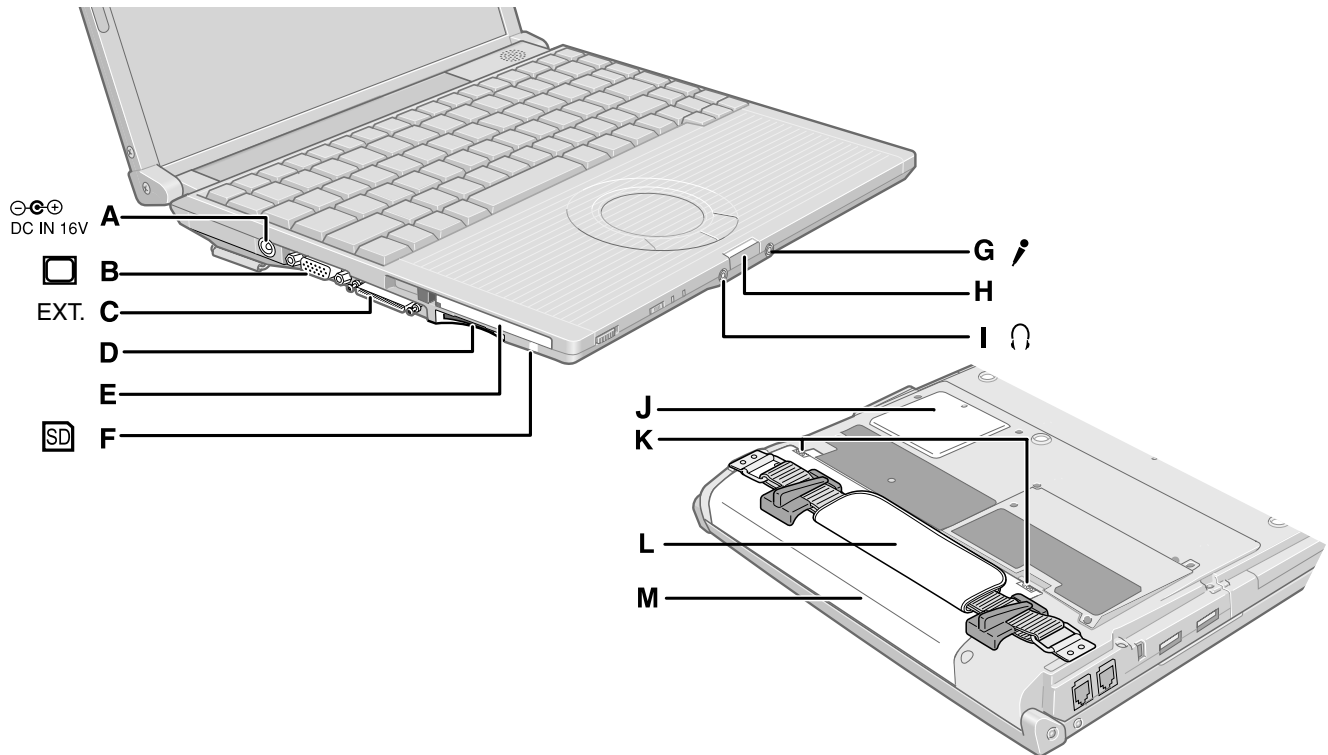

A : DC-IN Jack

B : External Display Port

If the Mini Port Replicator is connected to the computer, connect the external display to the external display port on the Mini Port Replicator. You cannot use the external display port on the computer.

C : Mini Port Replicator Connector

Connect the Mini Port Replicator (optional).

D : SD Memory Card Slot

E : PC Card Slot

F : SD Memory Card Indicator

Blinking: During access

G : Microphone Jack

A condenser microphone can be used. If other types of microphones are used, audio input may not be possible, or malfunctions may occur as a result.

When recording in stereo using a stereo microphone:

Double-click  in the notification area, click [Options] - [Properties], and add a check mark for [Recording], click [OK] - [Options] - [Advanced Controls] - [Advanced], remove a check mark for [Mono Microphone], and then click [Close].

When using a monaural microphone with a 2-terminal plug: With the settings outlined above, only audio on the left track will be recorded.

When monitoring the microphone audio using headphones, sounds on the left track cannot be heard, regardless of the above settings. This is a result of the computer's specifications, and is not a malfunction.

H : Latch

I : Headphone Jack

You can connect headphones or amplified speakers. When they are connected, audio from the internal speakers is not heard.

J : RAM Module Slot

K : Battery Latches

L : Hand Strap

M : Battery Pack

A lithium ion battery that is recyclable powers the product you have purchased. Please call 1-800-8-BATTERY for information on how to recycle this battery.

L'appareil que vous vous êtes procuré est alimenté par une batterie au lithium-ion. Pour des renseignements sur le recyclage de la batterie, veuillez composer le 1-800-8-BATTERY.

3 Block Diagram

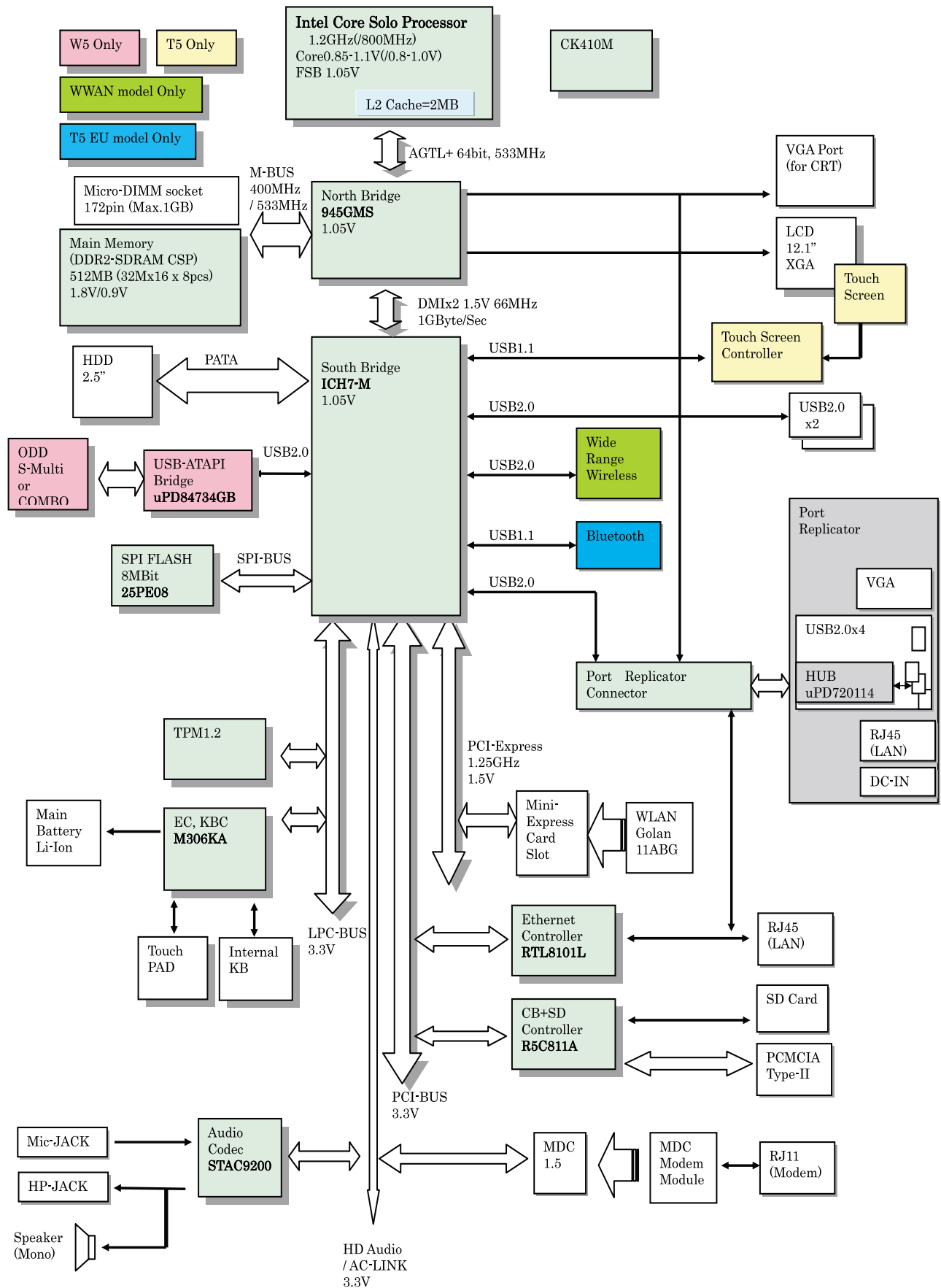

4 Diagnosis Procedure

4.1. Basic Procedures

The basic procedures for diagnosis, disassembly, and test of defective parts of a set to be repaired are summarized below. For details, refer to relevant pages in the Service Manual.

● Flow Chart

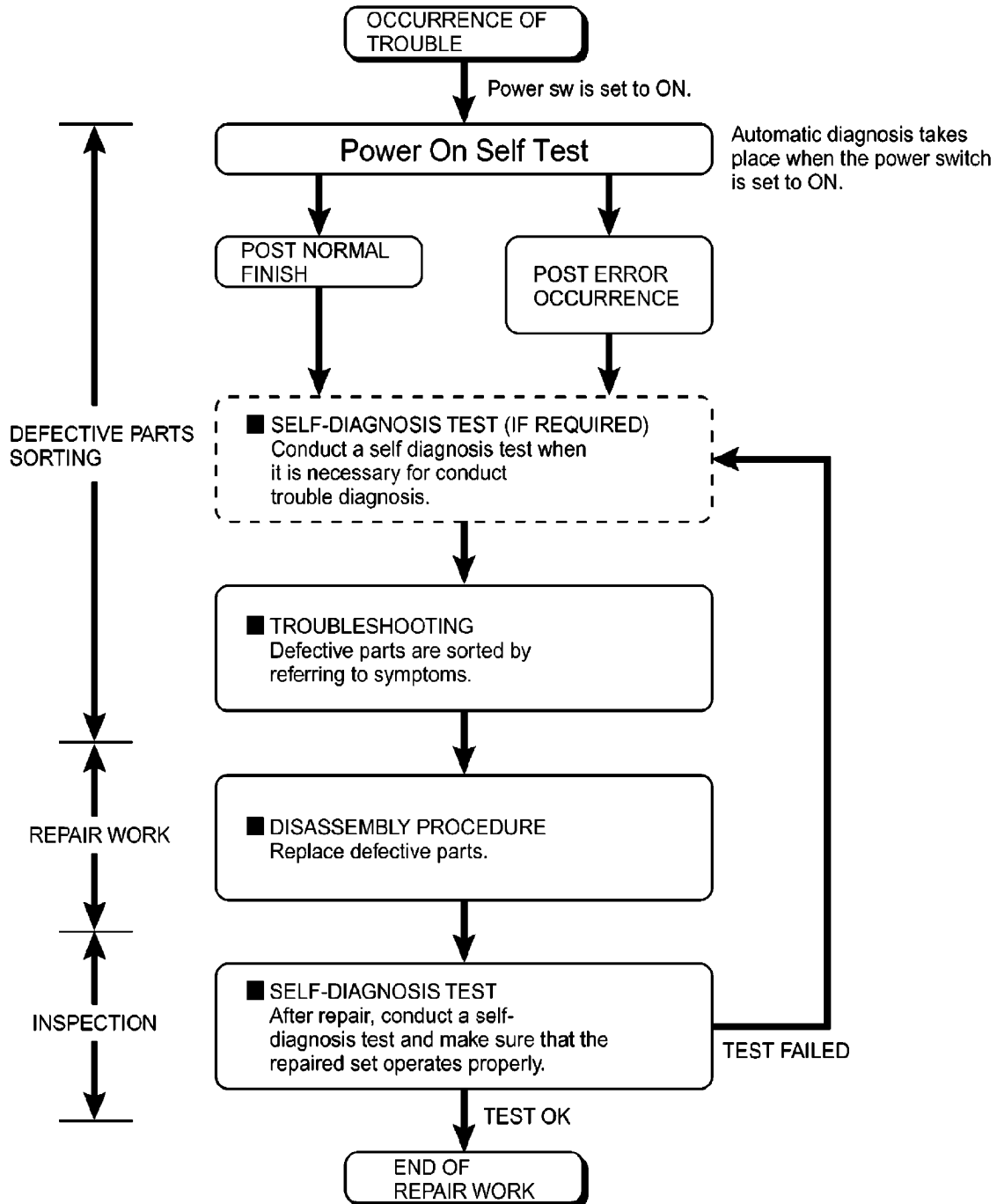

4.2. Troubleshooting

Please take note of the following two points with regard to troubleshooting:

1. Know-how of diagnosis upon occurrence of heavy troubles, e.g. Set cannot be turned ON, Set fails to start, No display on screen, etc.
2. Explanation of each trouble, mainly symptom of trouble in operation.

Flow Chart

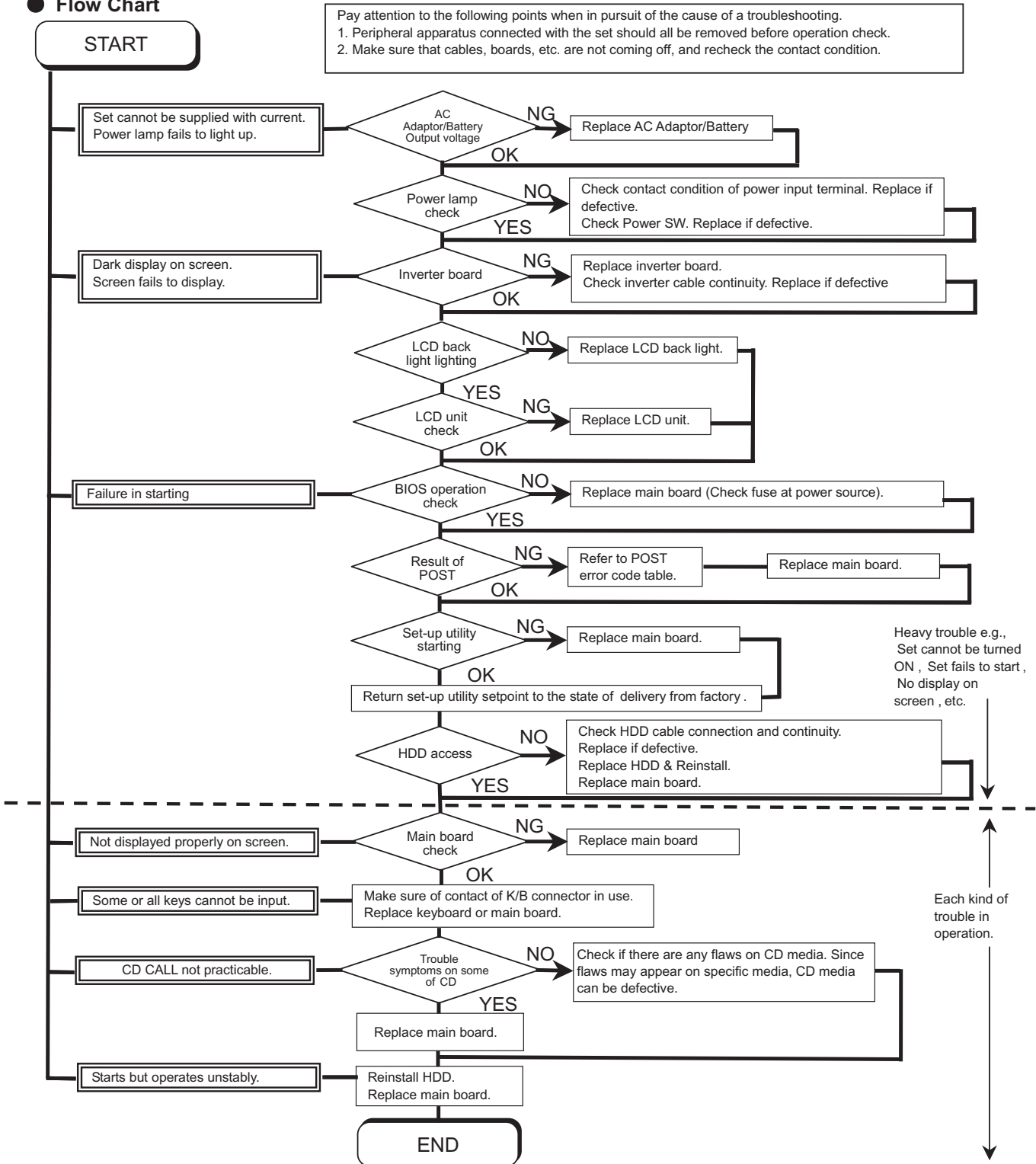

5 Power-On Self Test (Boot Check)

Outline of POST

The set has a boot check function called POST (Power-On Self Test) in it.

The condition of the main body is diagnosed by checking beep sound or error code.

StartTest begins automatically when power switch is set to ON.

Normal finishAfter memory checking, a beep sound is issued once and the set is placed into automatic stop.

Note: If no error occurs, nothing is displayed. (No display of OK, etc.)

Error Diagnosis by Checking Beep Signal Sound

The beep sound is as follows:



(Length of bar shows length of sound.)

■ = long sound (about 0.4 sec.), ■ = short sound (about 0.2 sec.), Length between sounds is about 0.1 sec.

Table of errors classified by beep sounds

Diagnosis	Beep signal sound	Error message
Main board	1(long sound)-2	BIOS ROM error
	1-2-2-3	BIOS ROM error
	1-3-1-1	RAM error
	1-3-1-3	Keyboard controller error
	1-3-4-1	RAM error
	1-3-4-3	RAM error
	1-4-1-1	RAM error
	2-1-2-3	BIOS ROM error
	2-2-3-1	Occurrence of unexpected offering

(Note) A beep sound is also issued in case of other I/O trouble.

6 List of Error Codes <Only when the port replicator is connected>

The following is a list of the messages that BIOS can display. Most of them occur during POST. Some of them display information about a hardware device, e.g., the amount of memory installed. Others may indicate a problem with a device, such as the way it has been configured. Following the list are explanations of the messages and remedies for reported problems. If your system displays one of except the messages marked below with an asterisk (*), write down the message and contact Panasonic Technical Support. If your system fails after you make changes in the Setup menus, reset the computer, enter Setup and install Setup defaults or correct the error.

0200 Failure Fixed Disk

Fixed disk in not working or not configured properly. Check to see if fixed disk is attached properly. Run Setup. Find out if the fixed-disk type is correctly identified.

0210 Stuck key

Stuck key on keyboard.

0211 Keyboard error

Keyboard not working.

0212 Keyboard Controller Failed

Keyboard controller failed test. May require replacing keyboard controller.

0213 Keyboard locked - Unlock key switch

Unlock the system to proceed.

0230 System RAM Failed at offset : *nnnn*

System RAM failed at offset *nnnn* of in the 64k block at which the error was detected.

0231 Shadow RAM Failed at offset : *nnnn*

Shadow RAM failed at offset *nnnn* of the 64k block at which the error was detected.

0232 Extended RAM Failed at offset : *nnnn*

Extended memory not working or not configured properly at offset *nnnn*.

0250 System battery is dead - Replace and run SETUP

The CMOS clock battery indicator shows the battery is dead. Replace the battery and run Setup to reconfigure the system.

***0251 System CMOS checksum bad - Default configuration used**

System CMOS has been corrupted or modified incorrectly, perhaps by an application program that changes data stored in CMOS. The BIOS installed Default SETUP Values. If you do not want these values, enter Setup and enter your own values. If the error persists, check the system battery or contact Panasonic Technical Support.

0260 System timer error

The timer test failed. Requires repair of system board.

0270 Real time clock error

Real-time clock fails BIOS test. May require board repair.

***0280 Previous boot incomplete - Default configuration used**

Previous POST did not complete successfully. POST loads default values and offers to run Setup. If the failure was caused by incorrect values and they are not corrected, the next boot will likely fail. On systems with control of **wait states**, improper Setup settings can also terminate POST and cause this error on the next boot. Run Setup and verify that the wait-state configuration is correct. This error is cleared the next time the system is booted.

0281 Memory Size found by POST differed from EISA CMOS

Memory size found by POST differed from EISA CMOS.

02D0 System cache error - Cache disabled

Contact Panasonic Technical Support.

02F0: CPU ID:

CPU socket number for Multi-Processor error.

02F4: EISA CMOS not writable

ServerBIOS2 test error: Cannot write to EISA CMOS.

02F5: DMA Test Failed

ServerBIOS2 test error: Cannot write to extended DMA (Direct Memory Access) registers.

02F6: Software NMI Failed

ServerBIOS2 test error: Cannot generate software NMI (Non-Maskable Interrupt).

02F7: Fail - Safe Timer NMI Failed

ServerBIOS2 test error: Fail-Safe Timer takes too long.

device address Conflict

Address conflict for specified *device*.

Allocation Error for: *device*

Run ISA or EISA Configuration Utility to resolve resource conflict for the specified *device*.

Failing Bits : *nnnn*

The hex number *nnnn* is a map of the bits at the RAM address which failed the memory test. Each 1 (one) in the map indicates a failed bit. See error 230,231 or 232 for offset address of the failure in System, Extended or Shadow memory.

Invalid System Configuration Data

Problem with NVRAM (CMOS) data.

I/O device IRQ conflict

I/O device IRQ conflict error.

Operating System not found

Operating system cannot be located on either drive A: or drive C:. Enter Setup and see if fixed disk and drive A: are properly identified.

Parity Check 1 *nnnn*

Parity error found in the system bus. BIOS attempts to locate the address and display it on the screen. If it cannot locate the address, it displays ????. Parity is a method for checking errors in binary data. A parity error indicates that some data has been corrupted.

Parity Check 2 *nnnn*

Parity error found in the I/O bus. BIOS attempts to locate the address and display it on the screen. If it cannot locate the address, it displays ????.

Press <F1> to resume, <F2> to Setup

Displayed after any recoverable error message. Press <F1> to start the boot process or <F2> to enter a Setup and change the settings. Write down and follow the information shown on the screen.

7 Self Diagnosis Test

As for the self-diagnosis test(PC-Diagnostic utility) to use this model, a standard test and the enhancing test by the module of the main body building in are possible.

- Notes To skip BIOS password
Use <Ctrl>+<F10> key to skip BIOS password or authentication of fingerprint.
This key is only for entering DIAG mode. Not available to boot the computer.
If customer set "HDD Lock", the DIAG program cannot perform HDD test.
*This key is for service purpose only. Do not disclose this information to unrelated others.

1. Beginning of self-diagnosis test

1-1. Setting of content of setup

1. The power supply of the computer is turned on.
2. " F2 " is pushed on the screen of "Panasonic" while " press <F2 to enter Setup> " is displayed.
3. The setup utility starts and then takes notes of the content of the BIOS setup of present set.
4. " F9 " is pushed, " Yes" is selected on the screen of " Is the default value loaded? ", and " Enter" is pushed.
5. " F10 " is pushed.
6. " Yes" is selected on the screen of the setup confirmation, and " Enter" is pushed.
7. The computer starts automatically.

Attention

- If the device which can be set is set to "Invalidity" by "Advanced" or "Security" menu, becomes an error by "PC-Diagnostic utility".
(It is judged that the device which can be set to "Invalidity" by "Main" menu such as "Flat pad" is normal if the controller operates normally though sets to "Invalidity" by the setup.)
- In the model with built-in DVD of the USB connection, even if DVD is normal, becomes an error if legacy USB is set to "Invalidity"

1-2. When you execute an automatic test

1. "Ctrl" + "F7" is pushed while the "Panasonic" start screen is displayed after the computer is started.
2. The test of all devices begins automatically by "PC-Diagnostic utility"s starting.

Attention

- It is a test which the customer who bought PC can execute. (As for HDD, the enhancing test is also possible.)
- A flat pad does not work for a while after starting "PC-Diagnostic utility".
- The movement of a flat pad might become abnormal If after RAM begins from the CPU/System test, a flat pad will be operated in about 30 seconds. In that case, restarts pushing "Alt" + "Ctrl" + "Del" key. Or, please start "PC-Diagnostic utility" again after doing the power supply switch in the slide, and turning off the power supply.

1-3. When you execute the enhancing test

1. Please let me discontinue diagnosing clicking  to end an automatic test.
2. Please click on the character of "D" "PC-Diagnostic utility" on the screen while pushing both of right "Shift" and left "Shift" keys.

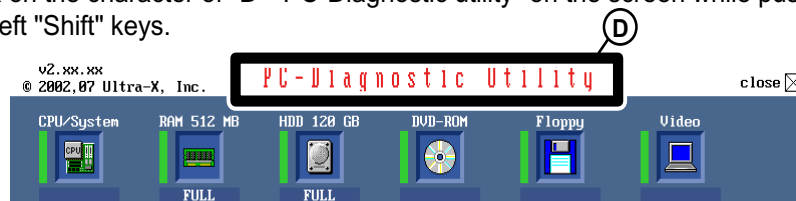

3. All devices which can select the enhancing test make the setting of the enhancing test possible.
4. The district device is made "FULL" display (enhancing test).
5. The test begins clicking .

*Please refer to item 4 for the error result of each test and the division of the breakdown part.

2. Operation of PC-Diagnostic Utility

- Only the device which can be inspected on the entire screen is displayed.
- The item does not appear when the device of wireless LAN etc. is not physically connected.
- The movement of the item must use an arrow key or a flat pad.



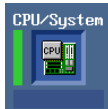

- As for the device under the diagnosis, blue and yellow are alternately displayed at the left of the icon.
- The diagnosis result of the device greens at the left of the icon when it is normal, and becomes red when abnormal.



- When the test of all devices ends, the test result is displayed under the right of the screen.



- Please click  while diagnosing when being stop on the way by the time the test of all devices ends.
- Please click  when you restart "PC-Diagnostic utility".

*Each device is tested from the beginning, and it is not possible to restart on the way.

2-1. Selection of tested device

-To test only a specific device, "Test" and "Do not test" of each device can be selected.

-The device which can select the enhancing test changes in order of "The standard is tested" and "Do not test" whenever the device icon is clicked.



Start the standard test



Do not test

Please begin testing clicking  if the selection of the tested device ends.

2-2. "PC-Diagnostic utility" End method

When of "Close" on the right of the screen is clicked, the computer reactivates automatically. Or, the power supply switch is done in the slide and the power supply is turned off.

2-3. The content of the setup is returned to the setting of the user

1. Turned on the computer.
2. "F2" is pushed on the screen while "Press<F2>to enter Setup" is displayed of "Panasonic".
3. Push "F10", and on the screen of "Is the change in the setting preserved and do end?"and then "Yes" is selected, and "Enter" is pushed.
4. The computer reactivates automatically.
5. The end option is chosen by the start menu, and the power supply of the computer is turned off.

Standard at test time

All devices other than RAM and HDD ----- about 1 minute

RAM standard test ----- 1 - 2 minutes

HDD standard test ----- 2 - 3 minutes

HDD enhancing test (60GB) ----- about 40 minutes

Ex.The standard when the standard <all device> is tested becomes $1+2+3=6$ minutes.

- There is greatly a difference from RAM test when the memory is increased according to the performance of the memory occasionally.
- Moreover, when the main body of PC under the test is a high temperature, it occasionally takes time.
- There is greatly a difference from HDD according to the performance of the drive occasionally.

7.1. Test Item and Division of trouble

Test item	Standard	Enhancing	Content of standard test	Content of enhancing test	Place with possibility of breakdown
CPU / SYSTEM	○	—	CPU is shifted to protected mode, and "Violation of the paging", "Operation of the violation of a privileged instruction", and DMA, INT, TIMER, and the RTC operation are confirmed.	—	CPU / Main board
RAM	○	—	All memory space is tested in a special memory access pattern based on "R.S.T . technology".	—	Memory / Mainboard
HDD	○	○	The record area frequently accessed with Microsoft Windows XP to test in about two minutes regardless of points of HDD is emphatically tested.	All record area is tested.	HDD / Mainboard / Cable / Connector
MODEM	○	—	It is confirmed not to find abnormality in the AC97 modem controller.	—	MODEM/ Mainboard
Wireless LAN	○	—	It is confirmed not to find abnormality in the Wireless LAN modem controller.	—	Wireless LAN board / Connector / Mainboard
Sound *5	○	—			
USB	○	○ ^{*1}	It is confirmed not to find abnormality in the USB controller.	It is confirmed not to find abnormality in the wiring between the USB controller and the connector by confirming the connection of the USB equipment connected with the USB connector.	Mainboard / Connector
LAN	○	○ ^{*2}	It is confirmed not to find abnormality in the LAN controller.	It is confirmed not to find abnormality in the wiring between the controller and the connector by connecting to HUB with LAN cable.	Mainboard / Connector
PC Card	○	—	It is confirmed not to find abnormality in the CardBus controller.	—	Mainboard
SD	○	—	It is confirmed not to find abnormality in the SD controller.	—	Mainboard
Keyboard	○	○ ^{*3}	It is confirmed not to find abnormality in keyboard controller's keyboard interface.	The key is actually input, and the operation is displayed on the screen.	Mainboard / Keyboard
Touch Pad	○	○ ^{*4}	Whether keyboard controller's mouse interface operates normally is confirmed.	The operation is actually displayed on the screen by operating the touch pad.	Mainboard / Touch Pad
DVD-ROM	○	○ ^{*6}	The drive is normally reset, and it is accessible is confirmed.	It is confirmed to be able to read media normally.	Mainboard / Touch Pad

Test Item	Standard	Enhanced	Content of Standard Test	Content of Extend Test	The place with possibility of breakdown
Touch Screen	○	○	It is confirmed not to find abnormality in the USB connection of Touch Screen. This test cannot find abnormality of Touch Screen.	Perform Touch Screen functionality practically. Operator has to judge PASS/FAIL with test result.	Main board/ Touch Screen
Bluetooth	○		It is confirmed not to find abnormality in the connection of Main board and Bluetooth module.	—	Bluetooth cable
Wireless WAN	○	—	It is confirmed not to find abnormality in the connection of Main board and Wireless WAN module.	—	WWAN cable
Floppy	○	—	It is confirmed not to find abnormality in the legacy FD drive. This test cannot find abnormality of mechanical breakdown. (e.g., Head, Motor)	—	FD Drive/ Main board (Super I/O)/ FDD cable FDD connector
Video	○	—	It is confirmed not to find abnormality in access to VRAM with VESA. The PC which uses main memory as VRAM may fail with main memory failure.	—	Main board (Chipset, Graphic Controller)/ Memory
GPS	○	—	It is confirmed not to find abnormality in the connection of Main board and GPS	—	GPS cable
IEEE1394	○	—	It is confirmed not to find abnormality in the IEEE1394 controller.	—	Main board (IEEE1394 Controller)
Express Card	—	○	—	It is confirmed not to find abnormality in the wiring between Chipset and Express Card.	Main board (Chipset)/ Express Card Connector
Smart Card	○	—	It is confirmed not to find abnormality in the Smart Card controller.	—	Main board (Smart Card Controller)
Serial Port	○	○ *7	It is confirmed not to find abnormality of Super I/O UART function. This test cannot find lack of wiring between Super I/O and Serial Connector.	It is confirmed not to find abnormality in the wiring between Super I/O and Serial Connector. This test cannot find failure of cable characteristic and device problems.	Main board (Super I/O)/ Serial Connector
Parallel Port	○	○ *8	It is confirmed not to find abnormality of Super I/O parallel function. This test cannot find lack of wiring between Super I/O and Parallel Connector.	It is confirmed not to find abnormality in the wiring between Super I/O and Parallel Connector. This test cannot find failure of cable characteristic and device problems.	Main board (Super I/O)/ Parallel Connector

*1 Please connect the USB device with the port (USB connector) which wants to test before the tests.

*2 Please connect LAN port with LAN HUB with LAN cable before the tests.

*3 The operator actually inputs the key, and the operator judges PASS/FAIL of the test.

*4 The operator actually operates the mouse, and the operator judges PASS/FAIL of the test.

*5 It is not abnormal though the sound is emitted from the speaker while testing.

※ When the test result is PASS, trouble is thought by not hearing of the sound under the test from the speaker and the headphone by the wiring of the audio output system.

*6 Please set DVD/CD media in the drive before the tests.

*7 Please set a Special Loop Back Connector Tool at serial connector for Enhanced Test. (This Connector Tool is same as the one used before.)

*8 Please set a Special Loop Back Connector Tool at parallel connector for Enhanced Test. (This Connector Tools is same as the one used before.)

8 Wiring Connection Diagram

——— Connection by Cable
 - - - - - Direct connection Connectors
 [] Parts on Bottom Side

Connection Cable		
※ 1	LCD Cable	DFJS1050ZA
※ 2	SP Cable	DFJS962ZA
※ 3	Antenna PCB-L	N1ZYYY000002
※ 4	Antenna PCB-R	N1ZYYY000003
※ 5	MODEM Cable	DFJS9732B
※ 6	LAN Cable	DFJS9582B
※ 7	PAD FFC	DFJK12U112BB
※ 8	FPC Unit,HDD	DL3UP1443AAA
※ 9	DC-IN Cable	DFJS1020YA
※ 10	USB Cable	DFJS980ZA

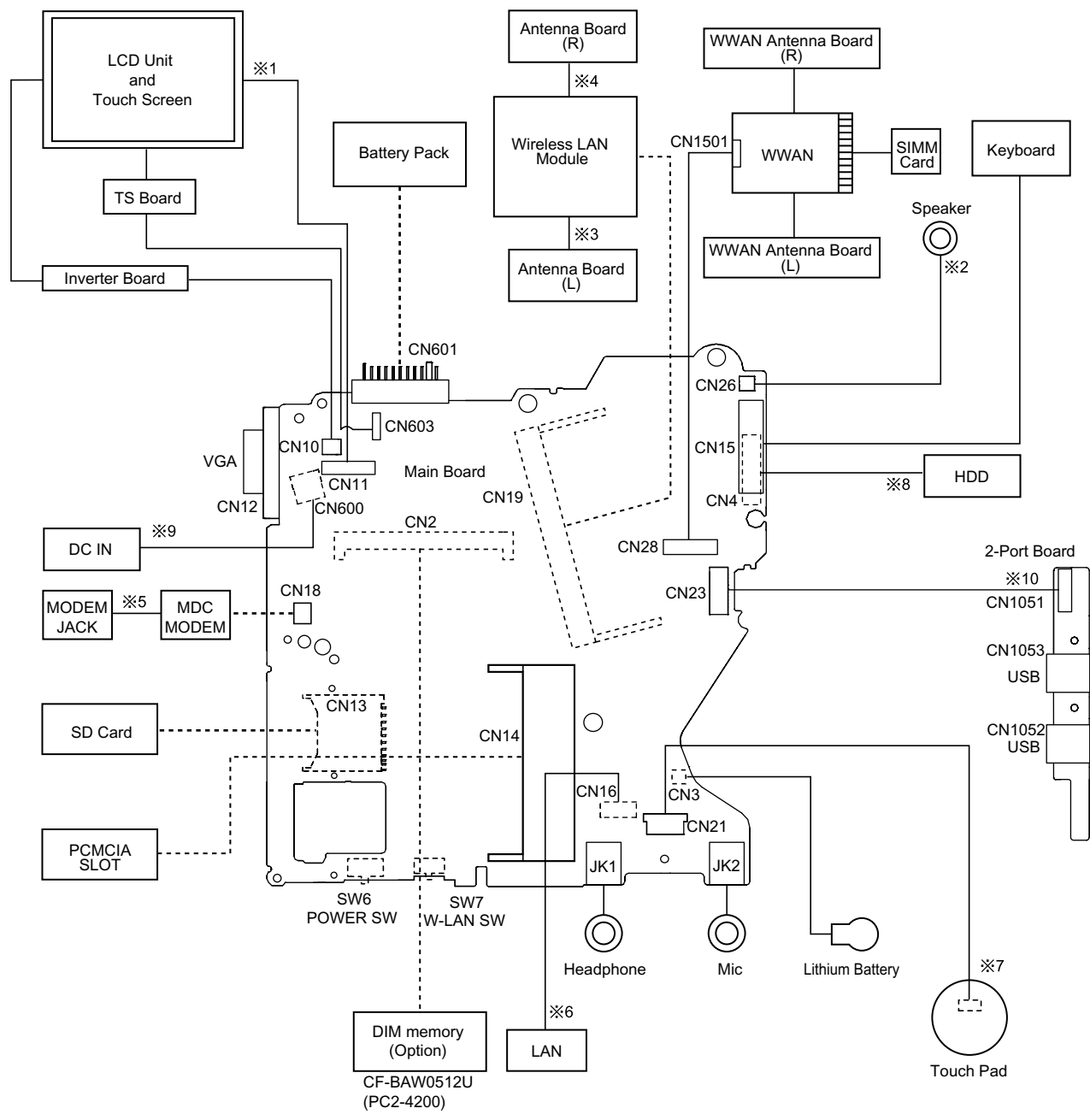

9 Disassembly instructions

9.1. Disassembly Flow Chart

● Main Unit

9.2.1.

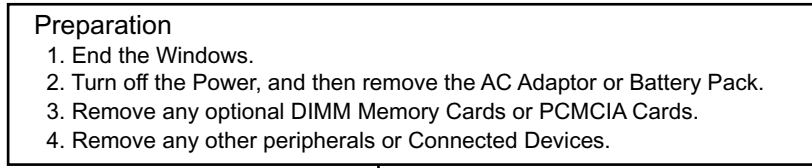

9.2.2.

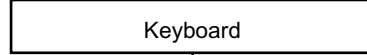

9.2.3.



9.2.4.

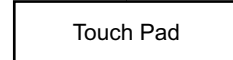

9.2.5.

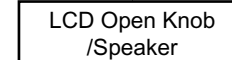

9.2.6.



9.2.7.



9.2.8.



9.2.9.

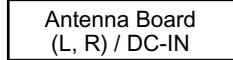

9.2.10.



9.2.11.



9.2.12.



● Display Unit

9.2.13.



9.2.14.

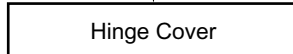

9.2.15.

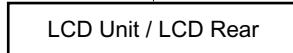

9.2.16.

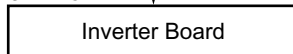

9.2.17.

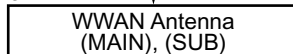

9.2.18.

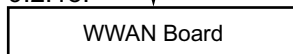

Main replaceable parts

<p>9.2.1. - Battery Pac</p> <p>9.2.2. - Kyeboard</p> <p>9.2.3. - Top Case</p> <p>9.2.4. - Touch Pad</p> <p>9.2.5. - LCD Knob</p> <p>9.2.6. - USB Board</p> <p>9.2.7. - HDD</p>	<p>9.2.8. - Main Board</p> <p>9.2.9. - Antenna Board (L, R)</p> <p>9.2.10. - W-LAN Unit</p> <p>9.2.11. - MDC MODEM</p> <p>9.2.12. - Card Bas ejector</p> <p>9.2.13. - LCD Unit</p> <p>9.2.14. - Hinge Cover</p> <p>9.2.15. - LCD Unit</p> <p>9.2.16. - Inverter Board</p> <p>9.2.17. -WWAN Antenna (MAIN), (SUB)</p> <p>9.2.18. -WWAN Board</p>
--	---

9.1. Disassembly Instructions

9.2.1. Preparation

Attention:

Before disassembly, be sure to perform the following steps.

1. End the Windows.
2. Turn off the power and then remove the AC adaptor.
3. Slide the hooks (A) and then remove the battery pack.
4. Remove the screw (A) and then remove the DIMM cover.
(Remove if the DIMM memory is equipped with)
Screw (A) : XSB2+4FNL (N16)

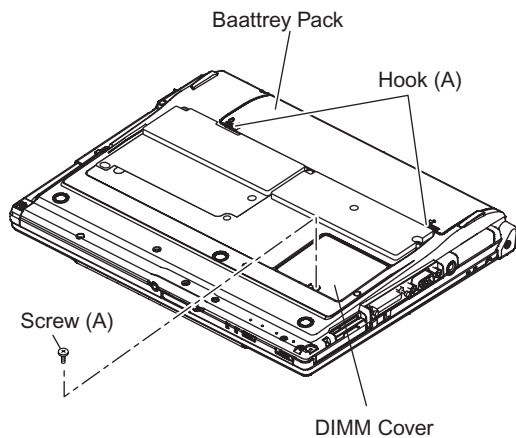

9.2.2. Removing the Keyboard

Preparation : perform the section 9.2.1.first.

1. Remove the 4 screws (B).
Screw (B) : DXQT2+E12FNL (N11)
2. Remove the 2 keyboard hook plates, and then remove the hook of back side of keyboard with screw driver.

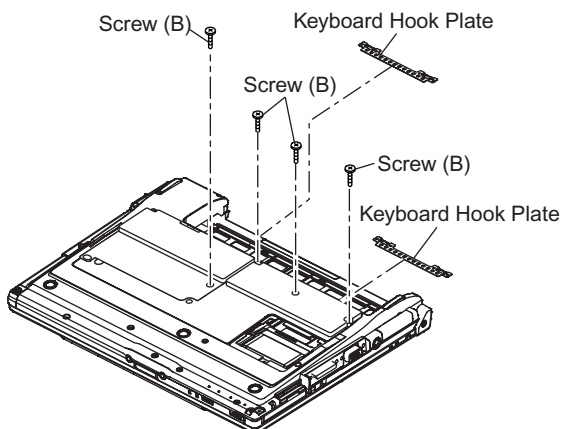

3. The LCD unit is opened up to about 90 °by operating the LCD knob.

4. Remove the 6 hooks (B).
5. Open the keyboard from LCD side and then turn it inside out on the top case.

Note:

It can remove with the keyboard hook plate.

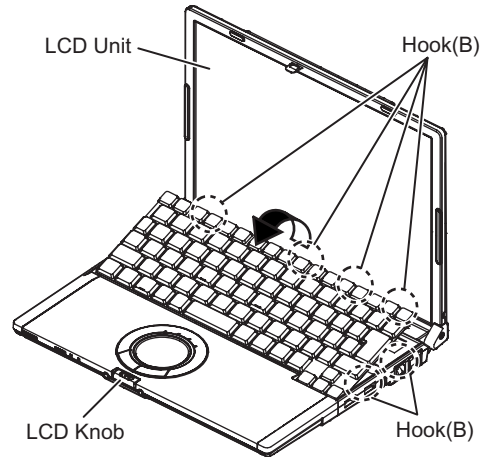

6. Remove the heat spreader from bottom of the keyboard.
7. Remove the keyboard FFC from the connector (CN15) and then remove the keyboard.

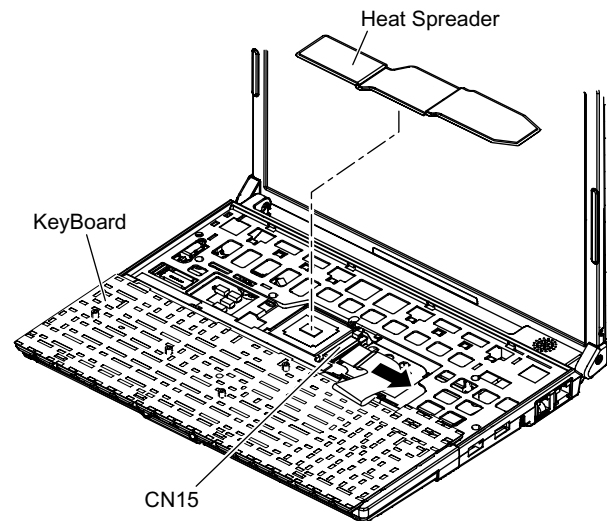

9.2.3. Removing the HDD

Preparation : perform the section 9.2.1., 9.2.2. first.

1. Remove the 2 screws (C) and then remove the HDD cover.
Screw (C) : DFHE5025XA (N1)
2. Peel off the tape from HDD FPC.
Tape : TPD-X0033A (S1001)

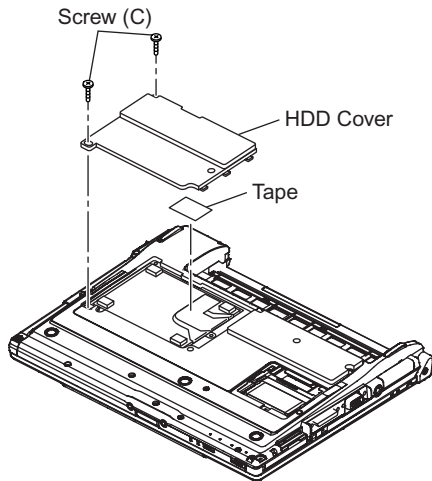

3. Lift up the HDD unit and remove FFCconnector and then remove the HDD unit.
4. HDD is taken out of the HDD case.

Note :

Please don't bend pins of HDD FPC connector when the HDD is removed.

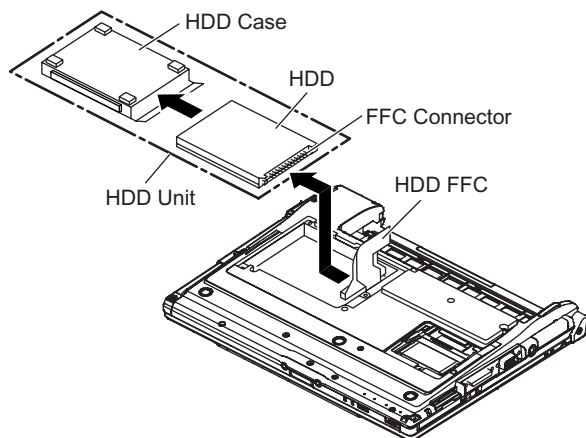

9.2.4. Removing the Top Case

Preparation : perform the section 9.2.1.,9.2.2. first.

1. Remove the 7 screws (D) and screws (E).
Screw (D) : DXHM0039ZA (N5)
Screw (E) : DXHM0057ZA (N7)

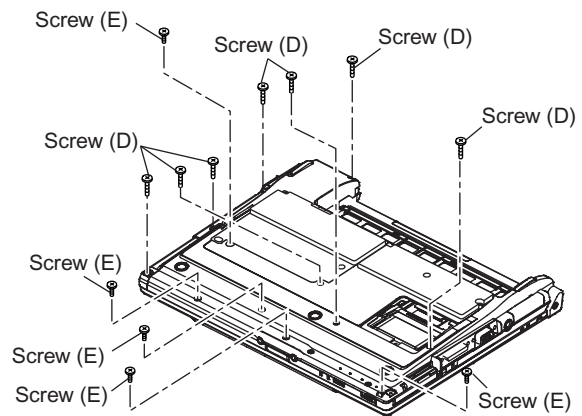

2. Remove the speaker cable from the connector (CN26).
3. Remove the side cover (R) as slide it to this side.
4. Remove the 1 screw (F), 3 screws (G) and 2 screws (H) from top case and then remove the top case.

Screw (F) : DXHM0056ZA (N6)
Screw (G) : DXQT2+E6FNL (N12)
Screw (H) : DXQT26+D8FCL (N14)

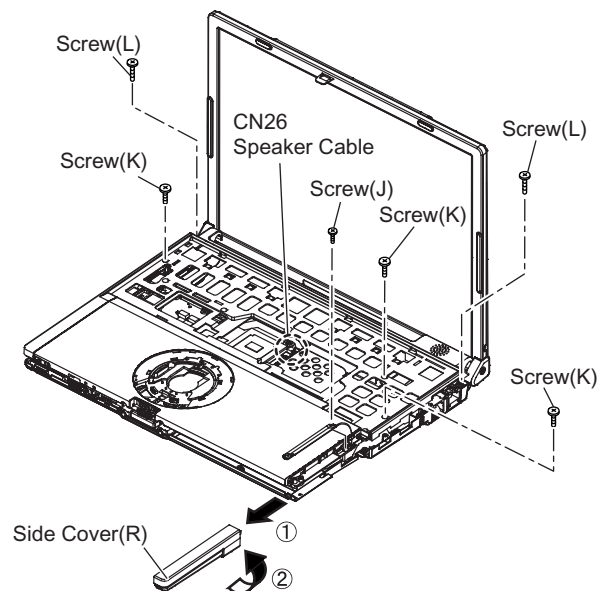

5. Lift up the top case and remove the pad FFC and then remove the top case.

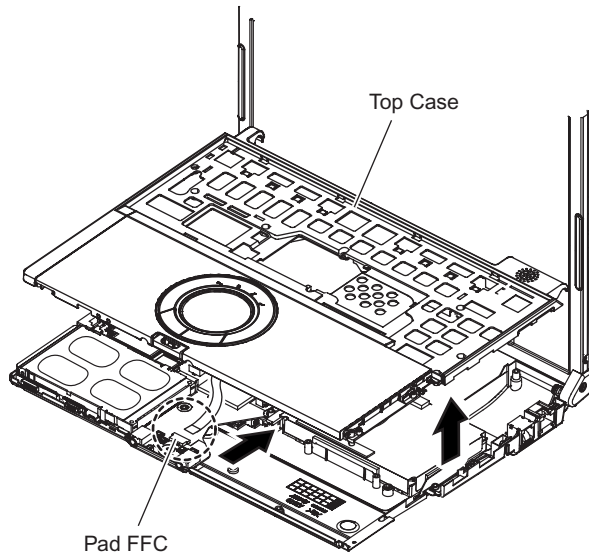

9.2.5. Removing the Touch Pad

Preparation : perform the section 9.2.1., 9.2.2. and 9.2.4. first.

1. Peel off the tape.
Tape : DFHP7140ZA (K37)
2. Depress to center the 6 hooks of the pad cover, (C) (D) (E) as order.

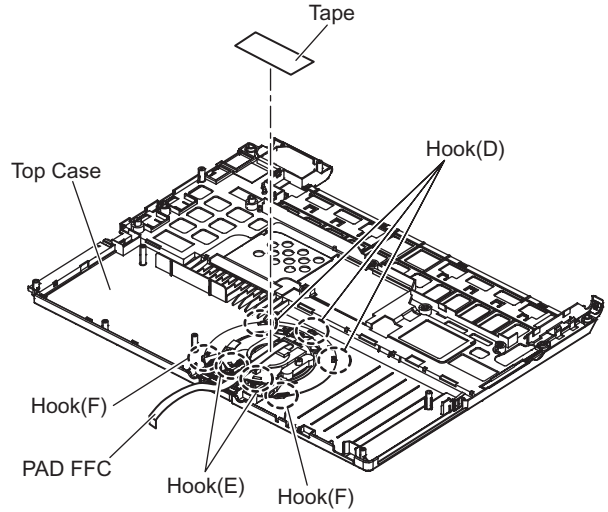

3. Remove the hook (F) and remove the touch pad.

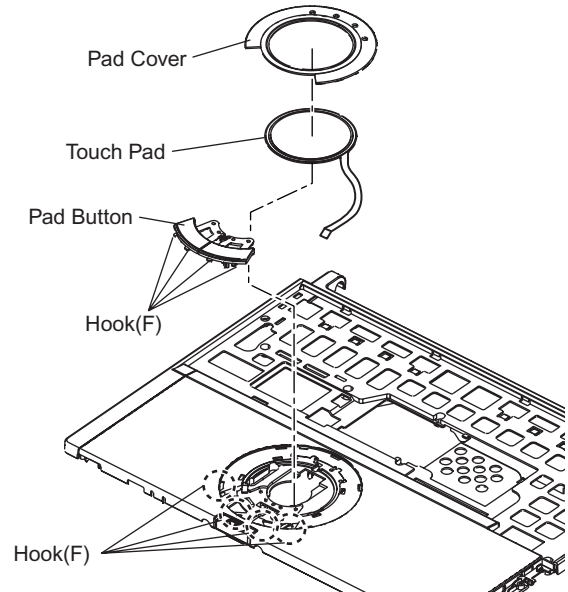

9.2.6. Removing the LCD Knob and the Speaker

Preparation : perform the section 9.2.1., 9.2.2. and 9.2.4. first.

1. Remove the latch spring from the top case.
2. Remove the hook of the LCD knob from stopper rib of the top case.
3. Peel off the tape on the speaker and speaker ring and then remove the speaker.

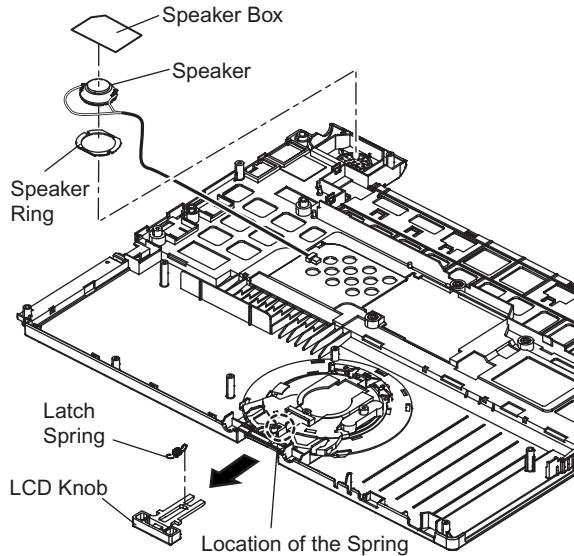

9.2.7. Removing the USB Board

Preparation : perform the section 9.2.1., 9.2.2. and 9.2.4. first.

1. Peel off the tapes and RJ cable sheet for clamp the USB cable.
Tape : TPD-X0033A (S1001)
RJ Cable Sheet : DFHR3C13ZA (K53)
2. Remove the connector (CN23) on the main board.
3. Remove the USB board from the bottom case.

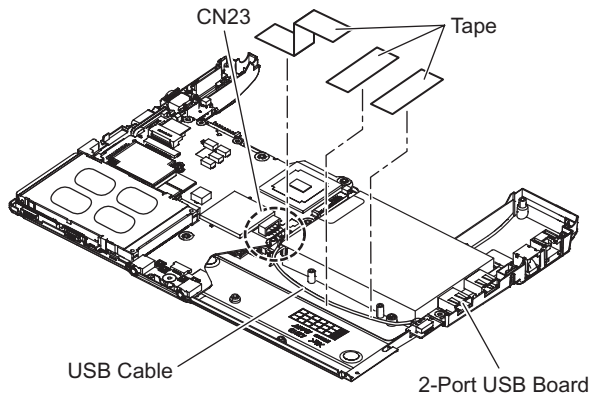

9.2.8. Removing the Main Board

Preparation : perform the section 9.2.1., 9.2.2. and 9.2.4. first.

1. Remove the 1 screw (I), 1 screw (J), 2 screws (K) and 2 screws (L).
Screw (I) : DXQT2+E10FNL (N10)
Screw (J) : DXQT2+D4FNL (N9)
Screw (K) : DFHE5035ZB (N2)
Screw (L) : K1YE5000022 (N1003)

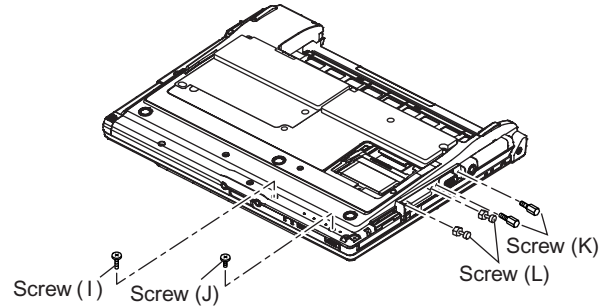

2. Remove the 2 screws (M).
Screw (M) : DXQT2+E6FNL (N12)
3. Remove the modem cable from the MDC modem.
4. Remove the side cover (L) from the bottom case.
5. Remove the DC jack holder on the DC-IN jack.

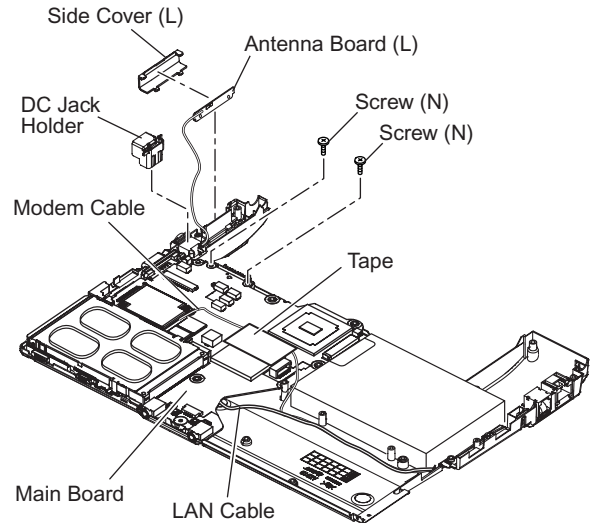

6. Remove the LCD cable connectors (CN10, CN11).

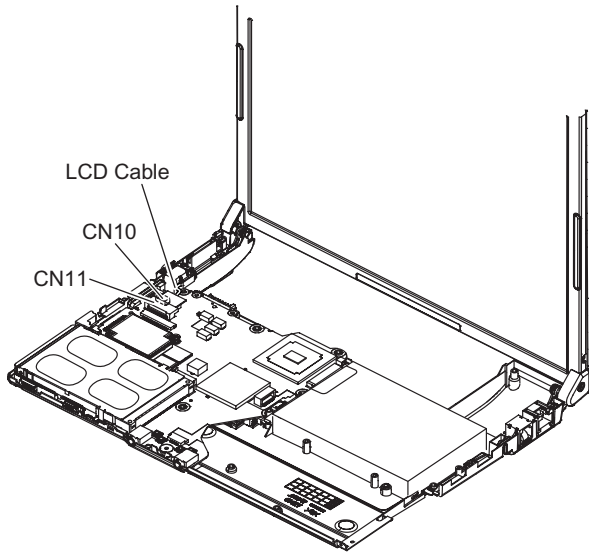

7. Turn it to arrow and remove the lithium battery connector (CN3) and HDD FPC connector (CN4).
8. Peel off the tape from LAN cable and then remove the LAN cable connector (CN16).
Tape : TPD-X0033A (S1001)
9. Remove the main board.

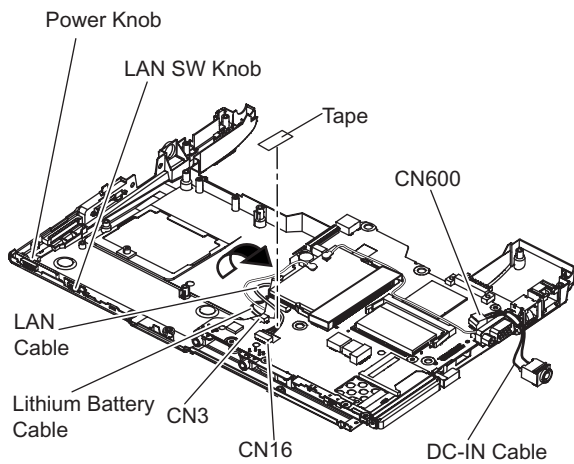

9.2.9. Removing the Antenna Board (L,R) and the DC-IN Cable

Preparation : perform the section 9.2.1., 9.2.2., 9.2.4. and 9.2.8. first.

1. Remove the antenna cable (L) from the main terminal and the antenna cable (R) from the AUX terminal and then remove the antenna board (L, R) from the bottom case.
2. Remove the DC-IN cable (CN600) from the main board.

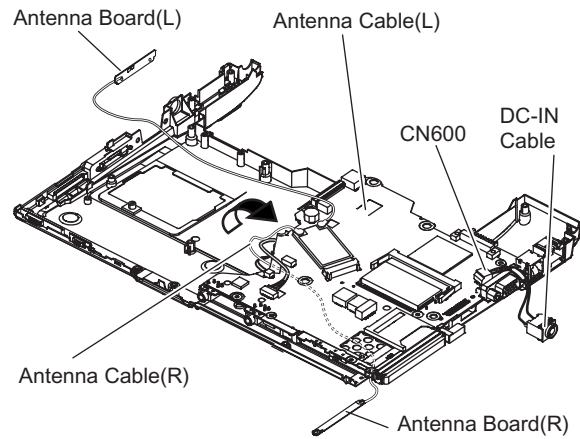

9.2.10. Removing the Wireless LAN Module

reparation : perform the section 9.2.1., 9.2.2., 9.2.4. and 9.2.8. first.

1. Remove the 2 screws (N) and then remove the Wireless LAN module.
Screw (N) : DXQT2+D25FNL (N8)

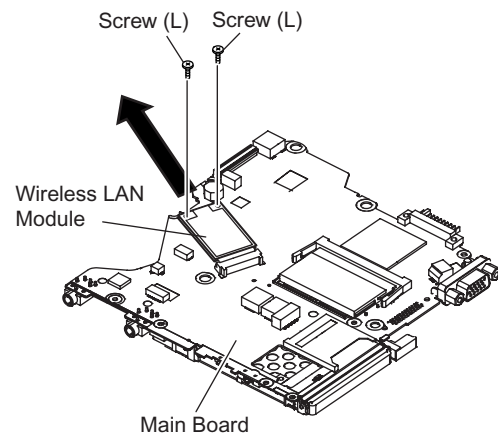

9.2.11. Removing the MODEM

Preparation : perform the section 9.2.1., 9.2.2., 9.2.4. and 9.2.8. first.

1. Remove the 2 screws (O).
Screw (O) : DXQT2+D25FNL (N8)
2. Remove the MODEM from main board connector (CN18) as vertical.

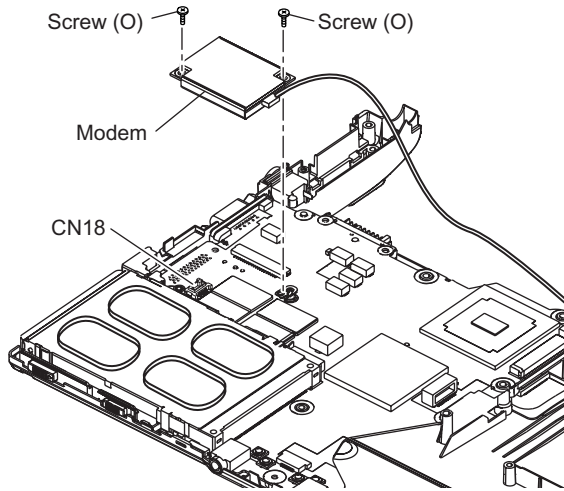

9.2.12. Removing the Card Bus Ejector

Preparation : perform the section 9.2.1., 9.2.2., 9.2.4. and 9.2.8. first.

1. Remove the 1 screw (P) from connection side of wireless LAN.
Screw (P) : DFHE5025XA (N1)

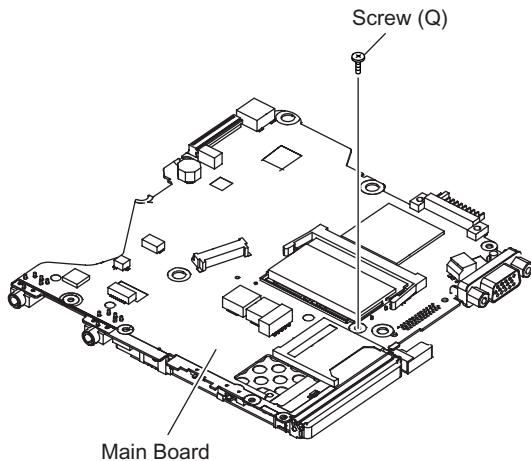

2. Turn to the card bus ejector side.
3. Remove the 2 hooks (G) from the connector (CN14).

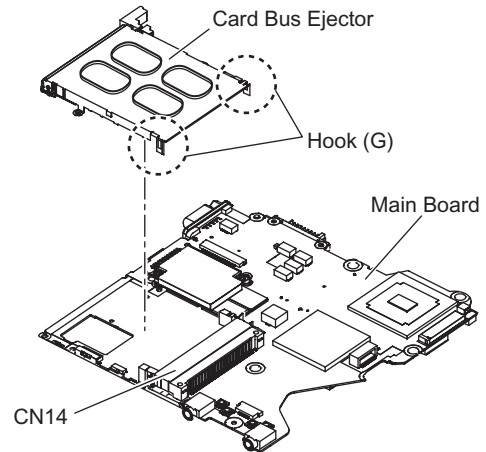

9.2.13. Removing the LCD Unit

Preparation : perform the section 9.2.1., 9.2.2. and 9.2.4. first.

1. Remove the 2 screws (Q).
Screw (Q) : DXQT26+D5FNL (N13)
2. Remove the LCD cable from the connector (CN11) of the main board.
3. Remove the inverter cable from the connector (CN10).
4. Disconnect the connectors (CN603, CN28) of the main board.

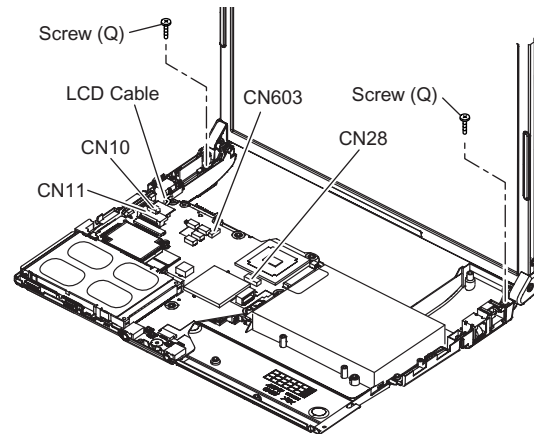

9.2.14. Removing the Hinge Cover

Preparation : perform the section 9.2.1., 9.2.2., 9.2.4. and 9.2.13. first.

1. Remove the 2 screws (R) and then remove the hinge cover (L, R).

Screw (R) : DRHM0108ZA (N1002)

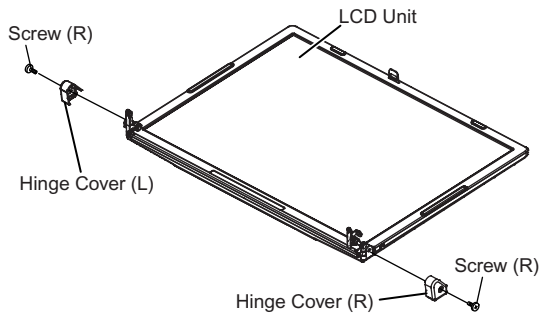

2. Remove the 2 screws (S).

Screw (S) : DRHM0076ZA (N1001)

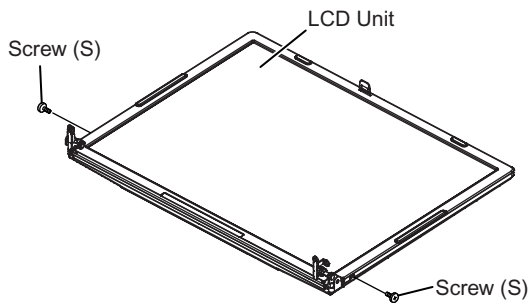

9.2.15. Removing the LCD Unit and the LCD Rear

Preparation : perform the section 9.2.1., 9.2.2., 9.2.4. and 9.2.13. to 9.2.14. first.

1. Remove the 2 LCD Ruber and then remove the 2 screws (T).

Screw (T) : DXHM0039ZA (N5)

2. Separate the LCD front and the LCD rear.
3. Remove the hinge (L), (R).

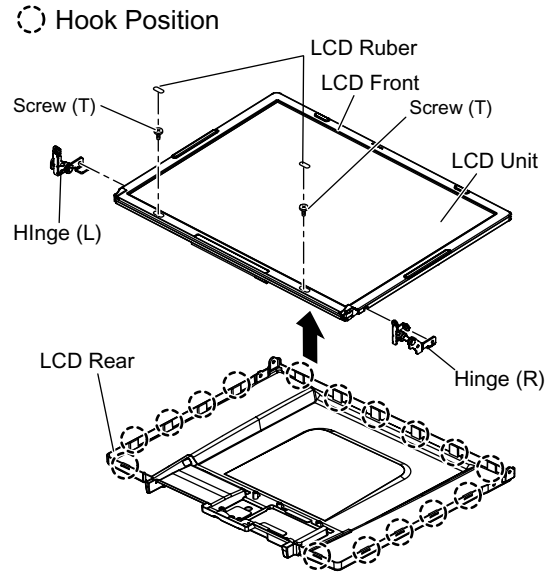

9.2.16. Removing the Inverter

Preparation : perform the section 9.2.1., 9.2.2., 9.2.4. and 9.2.13. to 9.2.15. first.

1. Remove the LCD cable from the inverter.
2. Peel off the conductive cloth (LCD cable) from the inverter.
3. Peel off the inverter tape from the inverter.

Inverter tape : DFHR3A95ZA (K49)

3. Remove the inverter with inverter box.

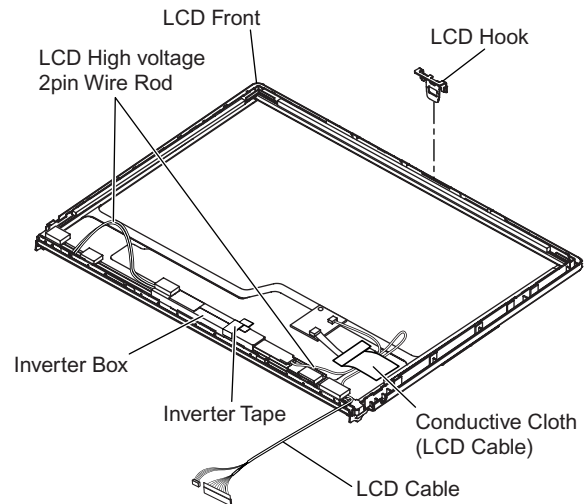

9.2.17. Removing the WWAN Antenna Board (MAIN), (SUB)

Preparation : perform the section 9.2.1., 9.2.2., 9.2.4. and 9.2.13. to 9.2.15. first.

1. Open the SIMM cover and then remove the 2 screws (U).

Screw (U) : DXHM0057ZA (N7)

2. Remove the antenna cover.

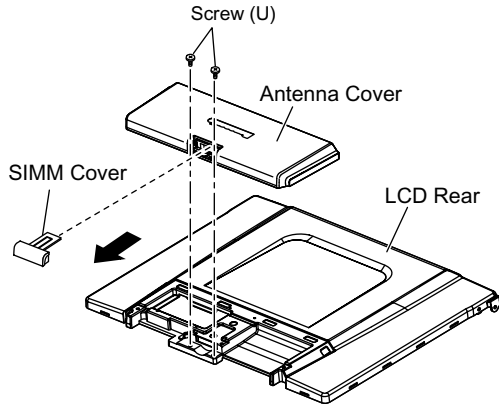

3. Peel off the LCD hold sheet.

LCD Hold Sheet : DFHR3E92ZA (K1028)

4. Peel off the 2 cable fixed sheets and cable blind sheet.

Cable Fixed Sheet : DFHR8526ZA (K1030)

Cable Blind Sheet : DFGX0475ZA (K1003)

5. Remove the each 2 screws (V) and then remove the antenna board (MAIN), (SUB).

Screw (V) : DFHE5025XA (N1)

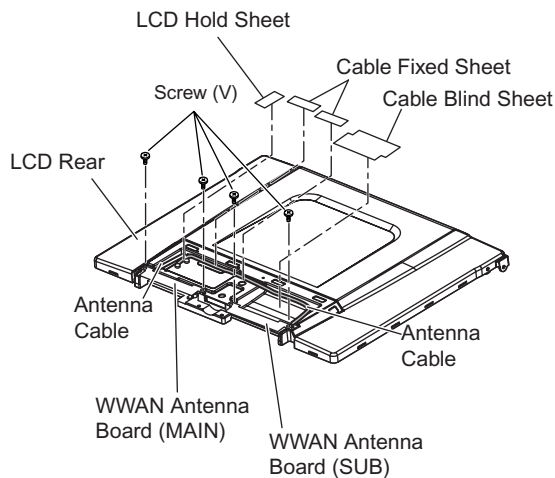

9.2.18. Removing the WWAN Board / LCD Hook WAN

Preparation : perform the section 9.2.1., 9.2.2., 9.2.4. and 9.2.13. to 9.2.15., 9.2.17. first.

1. Disconnect the WM cable from the connector (CN1501).

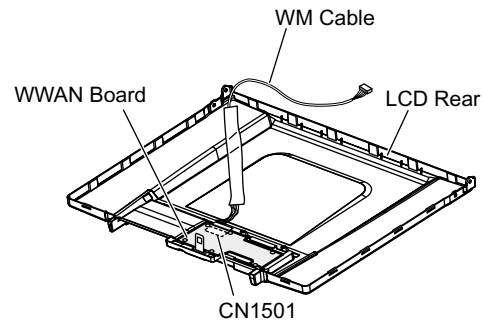

2. Remove the 6 screws (W) and then remove the WWAN board.

Screw (W) : DFHE5025XA (N1)

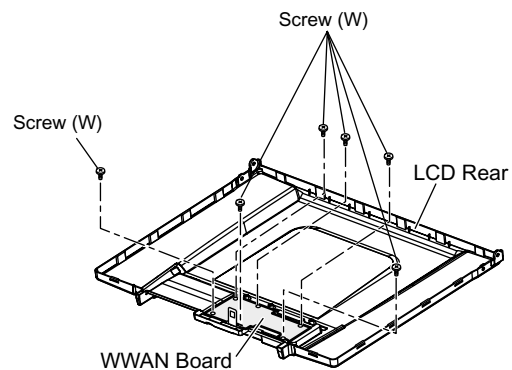

9.3. Reassembly instructions

9.3.1. Attention when CF-T5L series is repaired

- Please execute writing BIOS ID when you exchange the main board.
- Parts (sheet and rubber) etc.related various the conductive cloth and heat spreader cannot be recycled.Use new parts.

9.3.2. Assembly knowhow of the LCD

9.3.2.1. Assembly of the LCD Front

- LCD Side Rubber, LCD Batt Rubber and LCD Magnet are not put out from the concave part.
- It is noted that the finger does not touch the paste side when there are put.

Does not run aground in a surrounding rib.

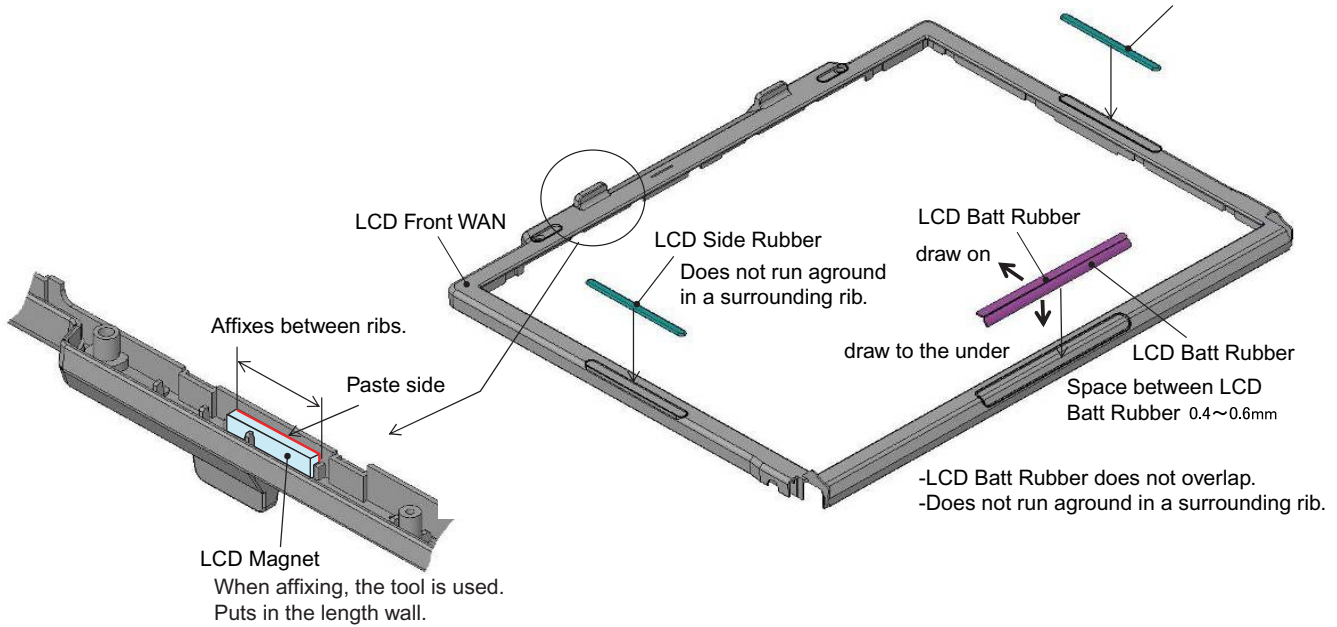

9.3.2.2. Putting Front TP Cushion

- Affixation of LCD Front TP CUSHION/A/B/C/Tape

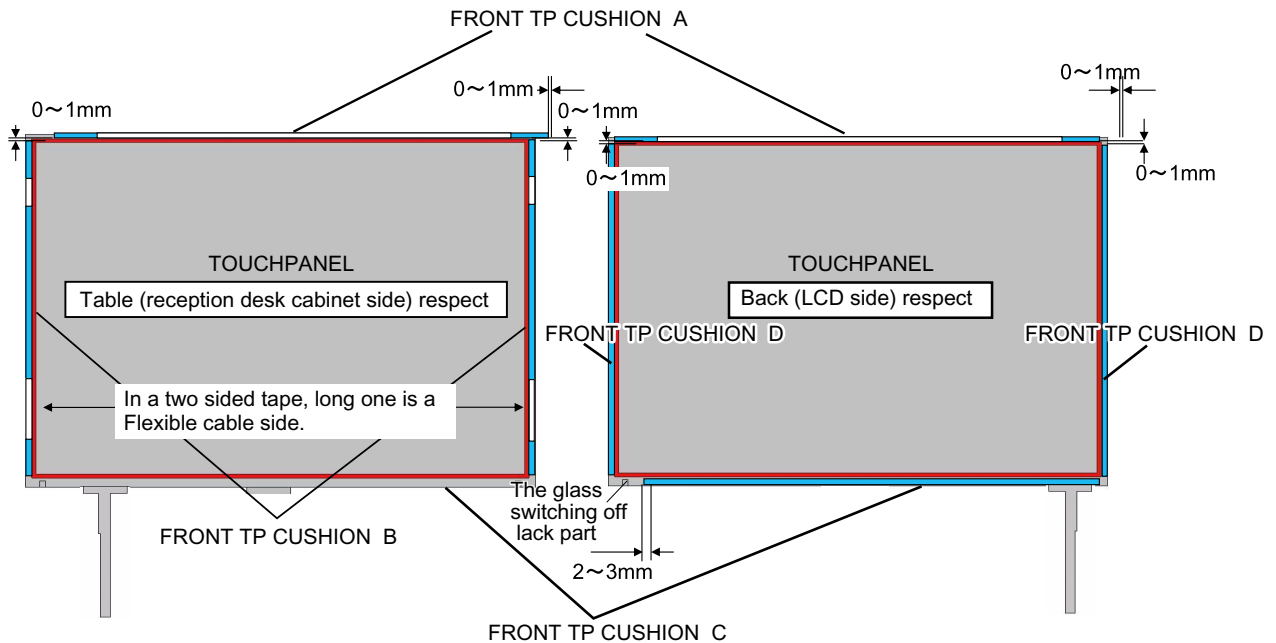

9.3.2.3. Putting TP Flexible Protection Tape

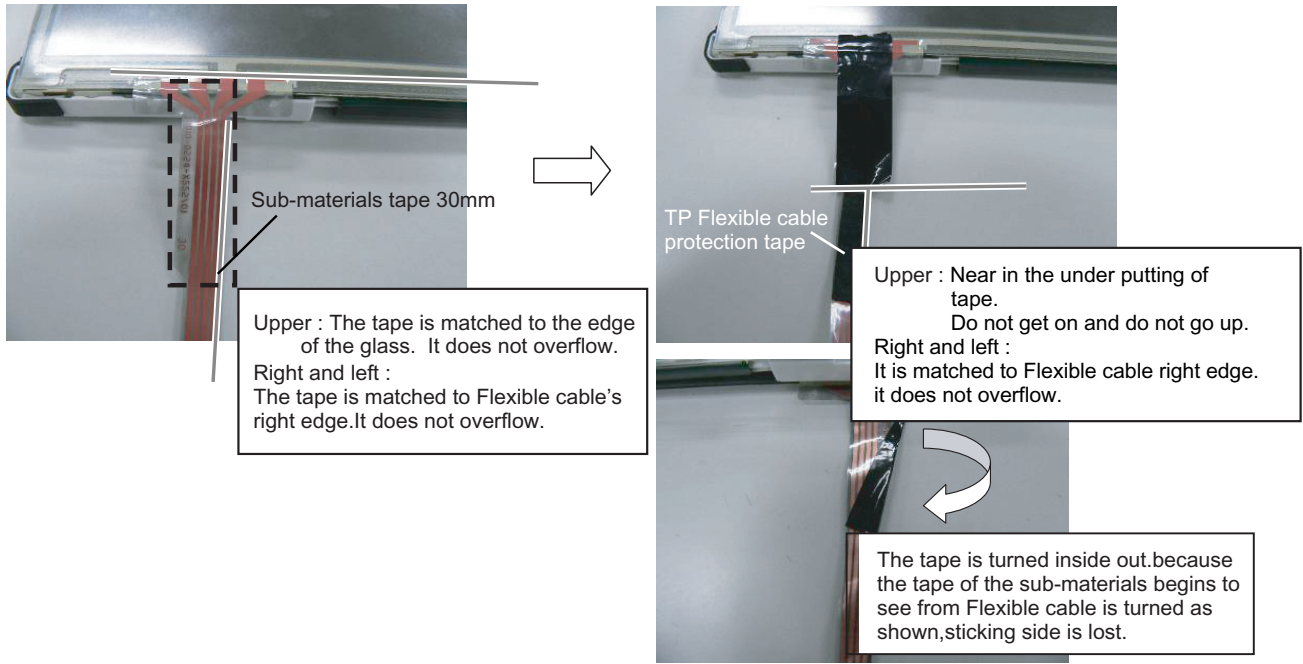

9.3.2.4. Putting LCD Side Dumpers

- Put the Side Dumper

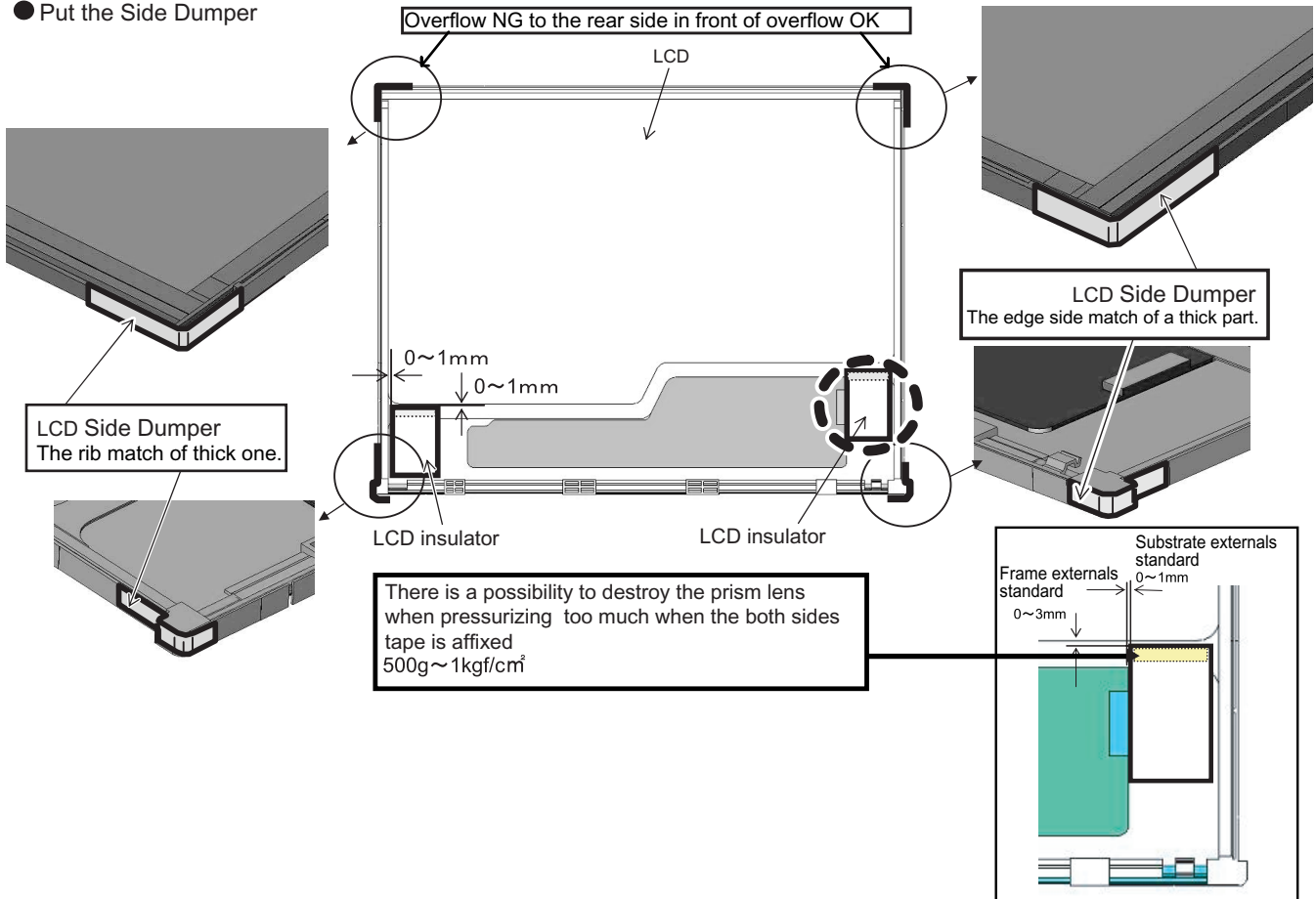

9.3.2.5. Assembly of the LCD Unit

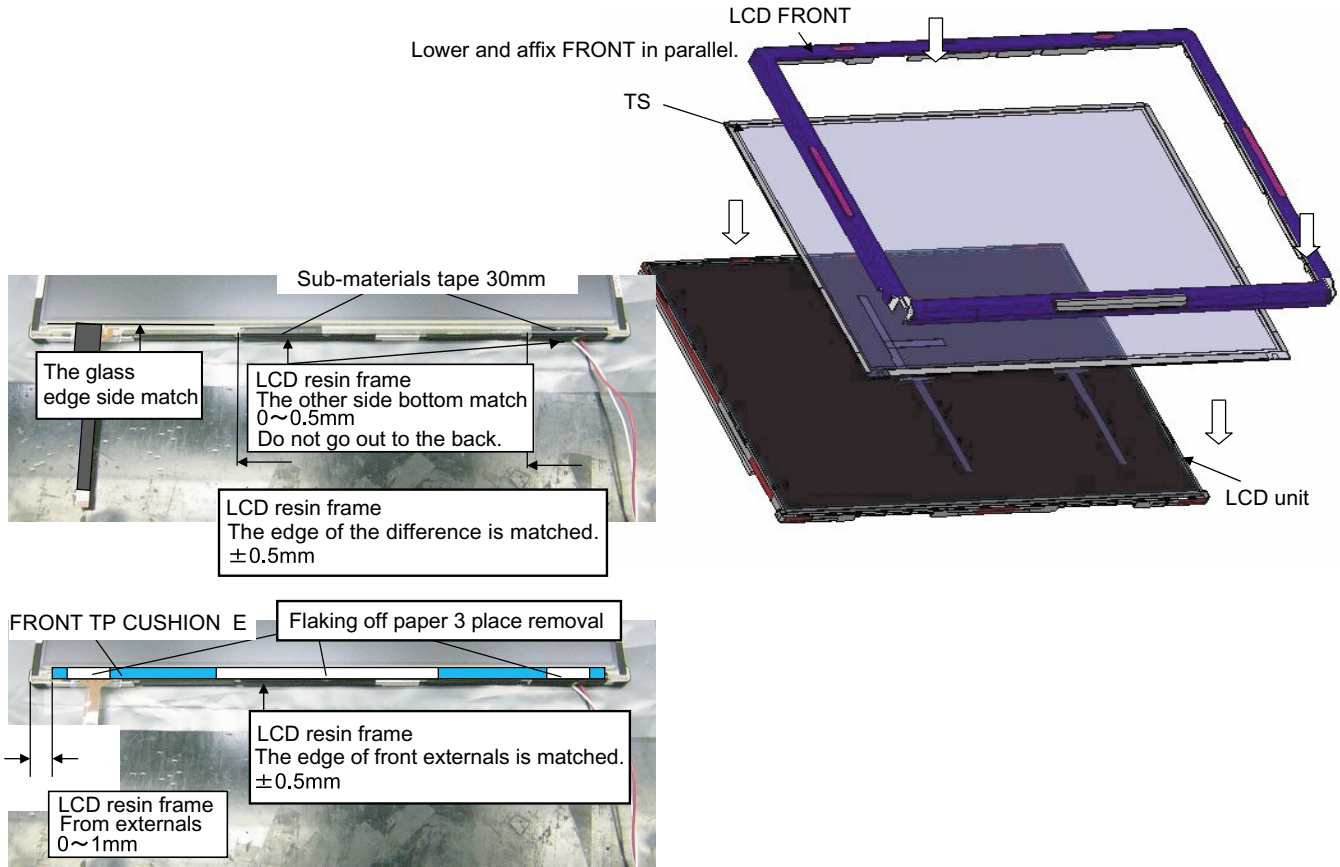

9.3.2.6. Assembly of the LCD Dumper

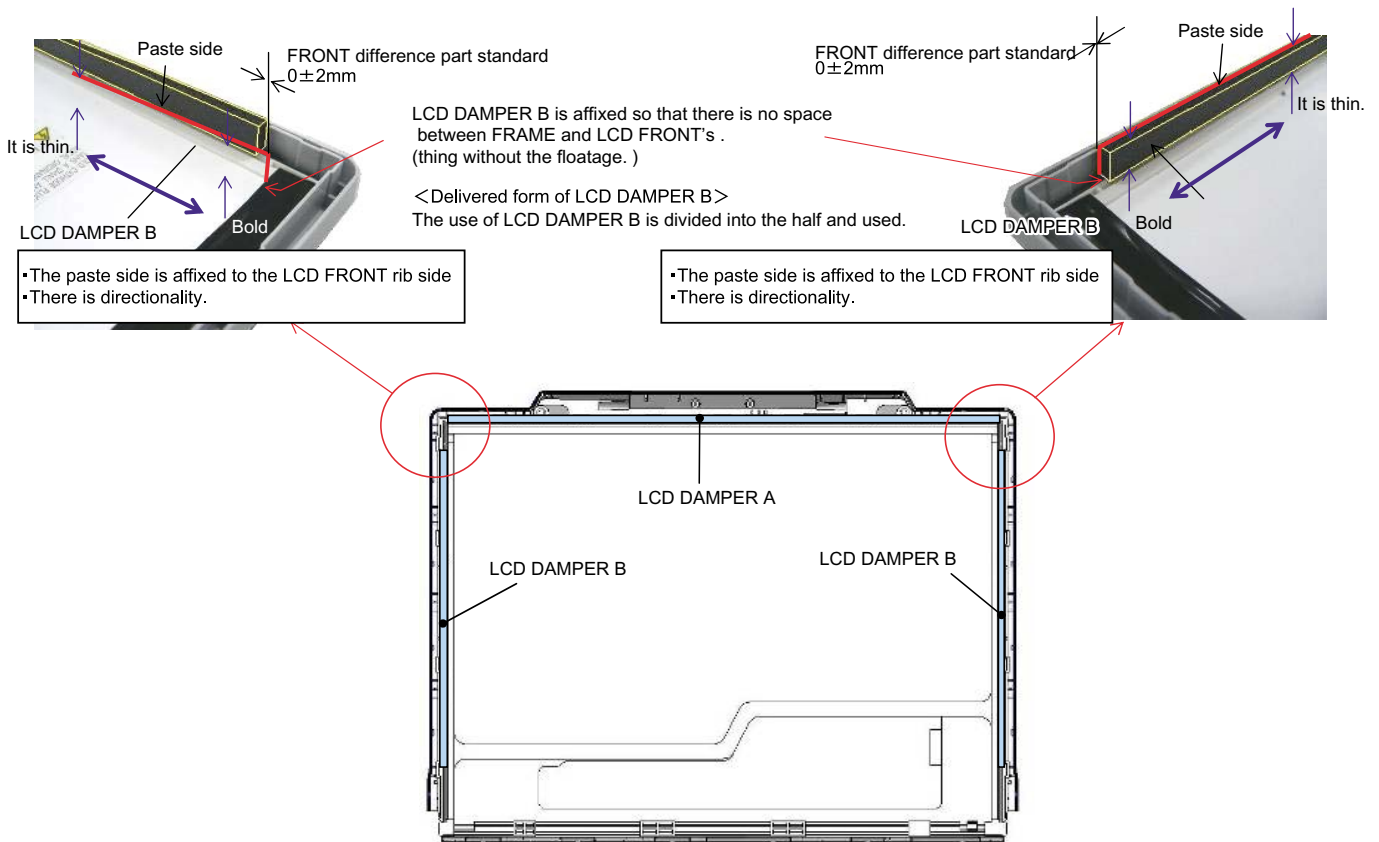

●MAGNET DAMPER affixation

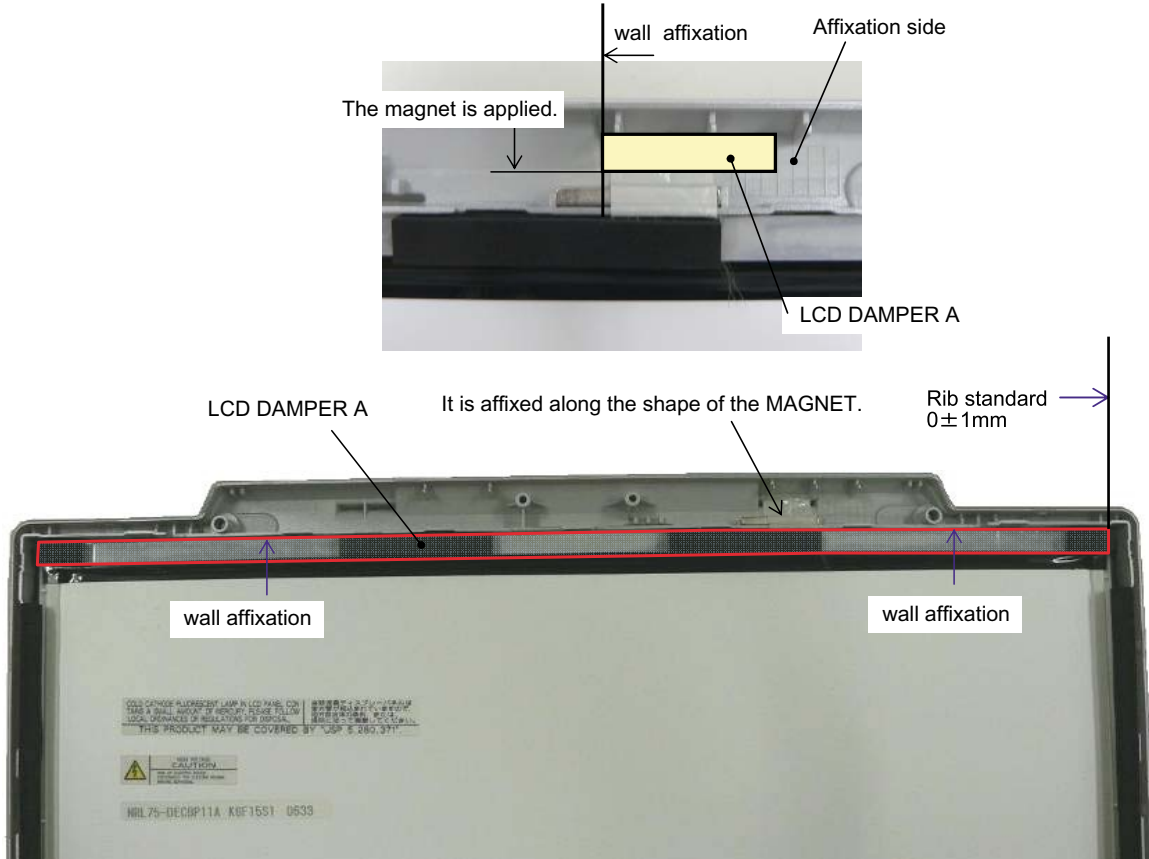

9.3.2.7. Connecting LCD Cable

The LCD cable is connected with the inverter.
 Wraps around the PET tape connector.
 The inverter is inserted in the inverter box and then affixes to rear case.
 LCD/inverter cable is connected.
 The connector is fixed with the tape of the inverter box.

Safety important parts Inverter



Safety Work

affixes in a connector externals putting (wrapping) together.

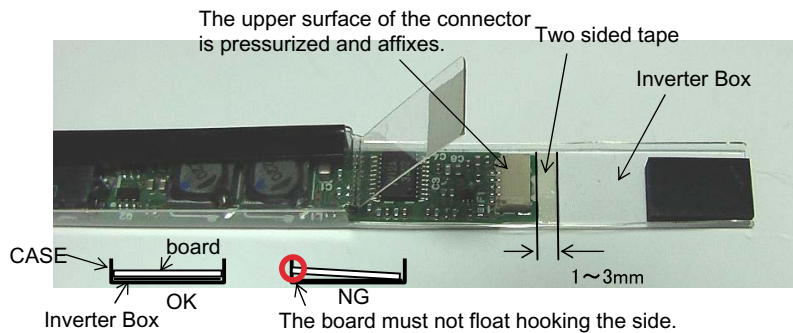
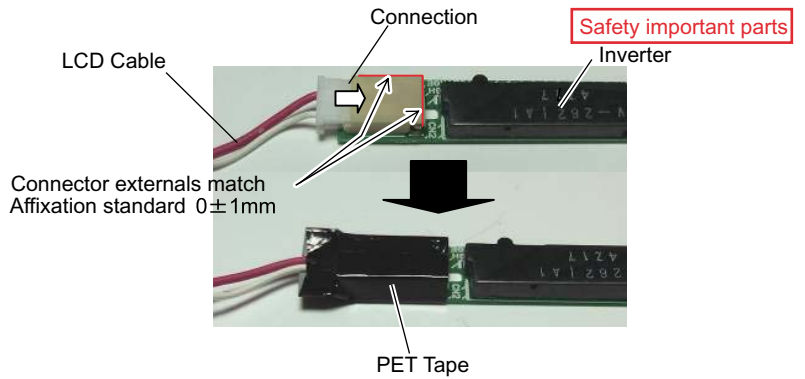

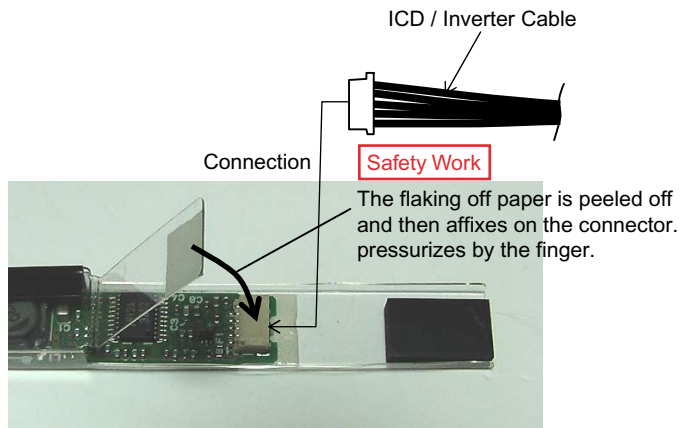

9.3.2.8. Assembly of the Inverter and Putting Inverter Tapes

A two sided tape of the Inverter Case bottom is peeled off, and put.

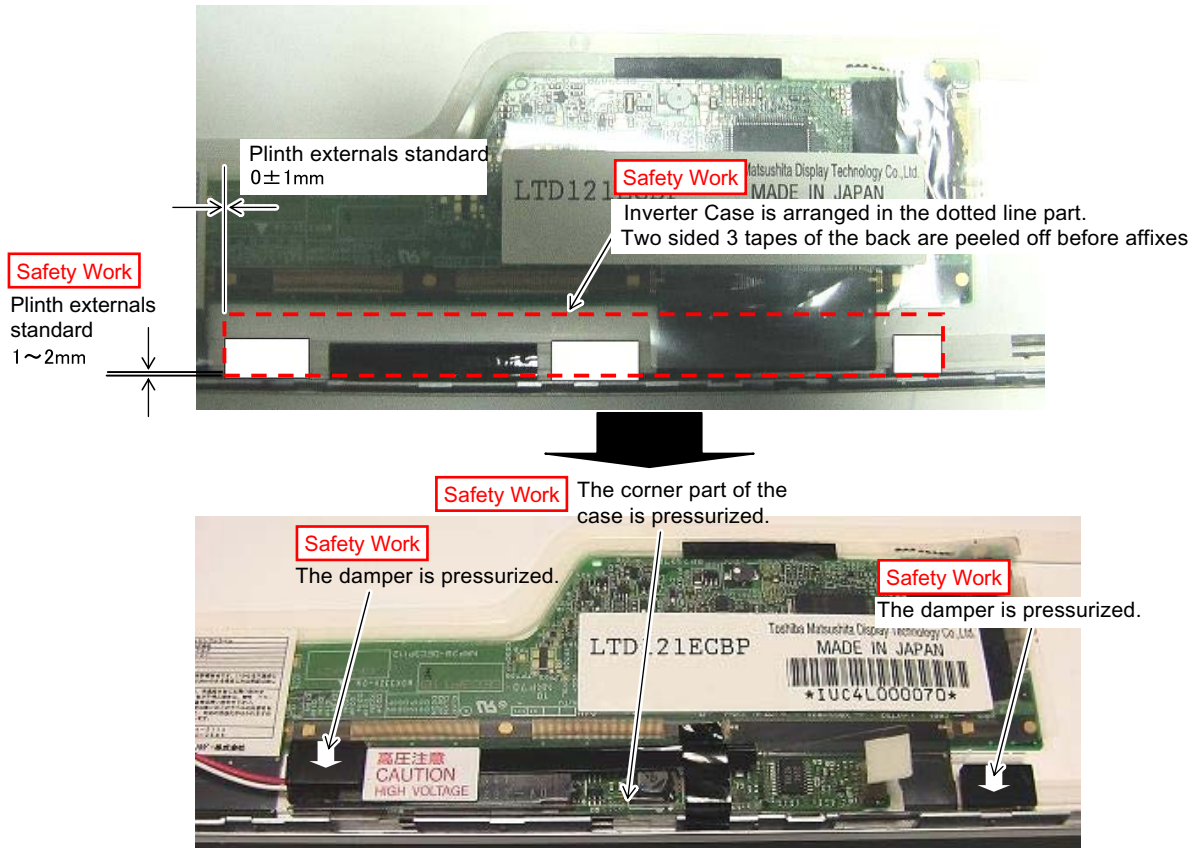

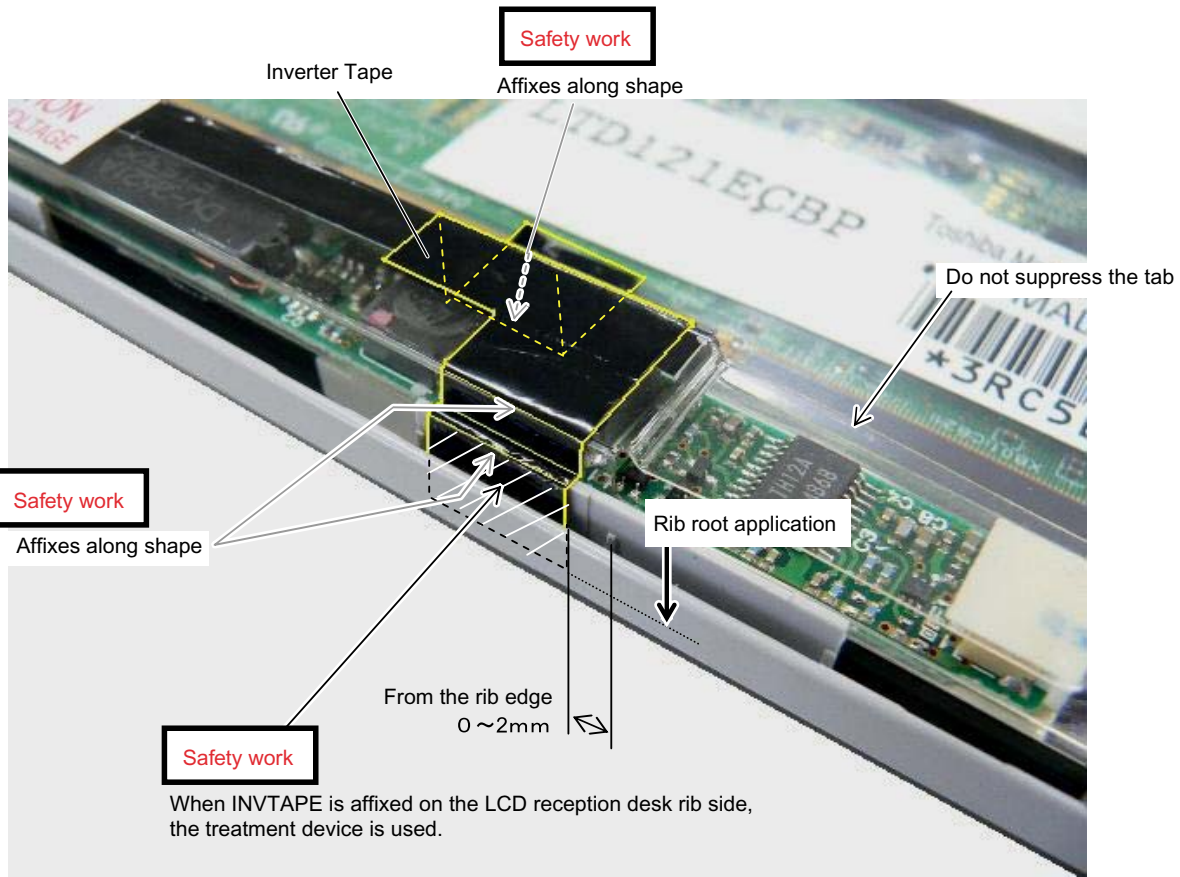

9.3.2.9. Line processing LCD cable (1)

●LCD cable Wiring

The built-in order①

- Peel off the LCD Sheet and then put the PET Tape

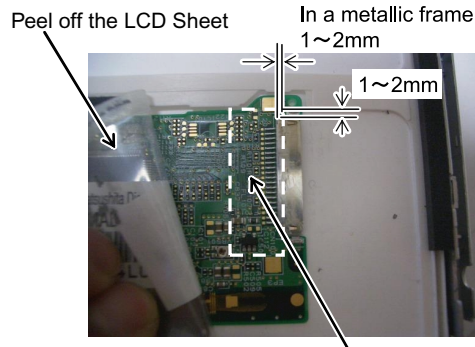

Safety work PET TAPE(Width:10mm L=30mm)
Overlaps on the connector and Affixes

The built-in order②

- Connect the LCD Cable

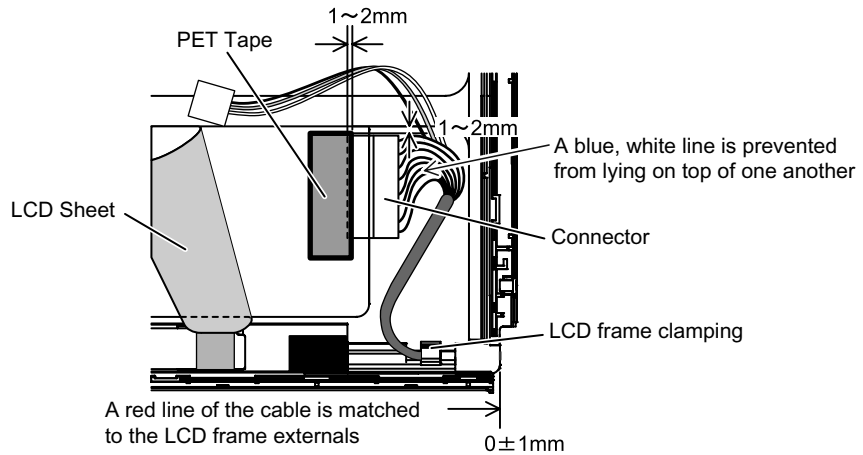

The built-in order③

- The cable is processed to the LCD frame clamping

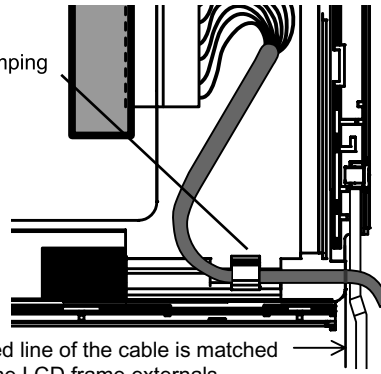

A red line of the cable is matched to the LCD frame externals
Management size $0 \pm 1\text{mm}$

9.3.2.10. Putting PET Tape

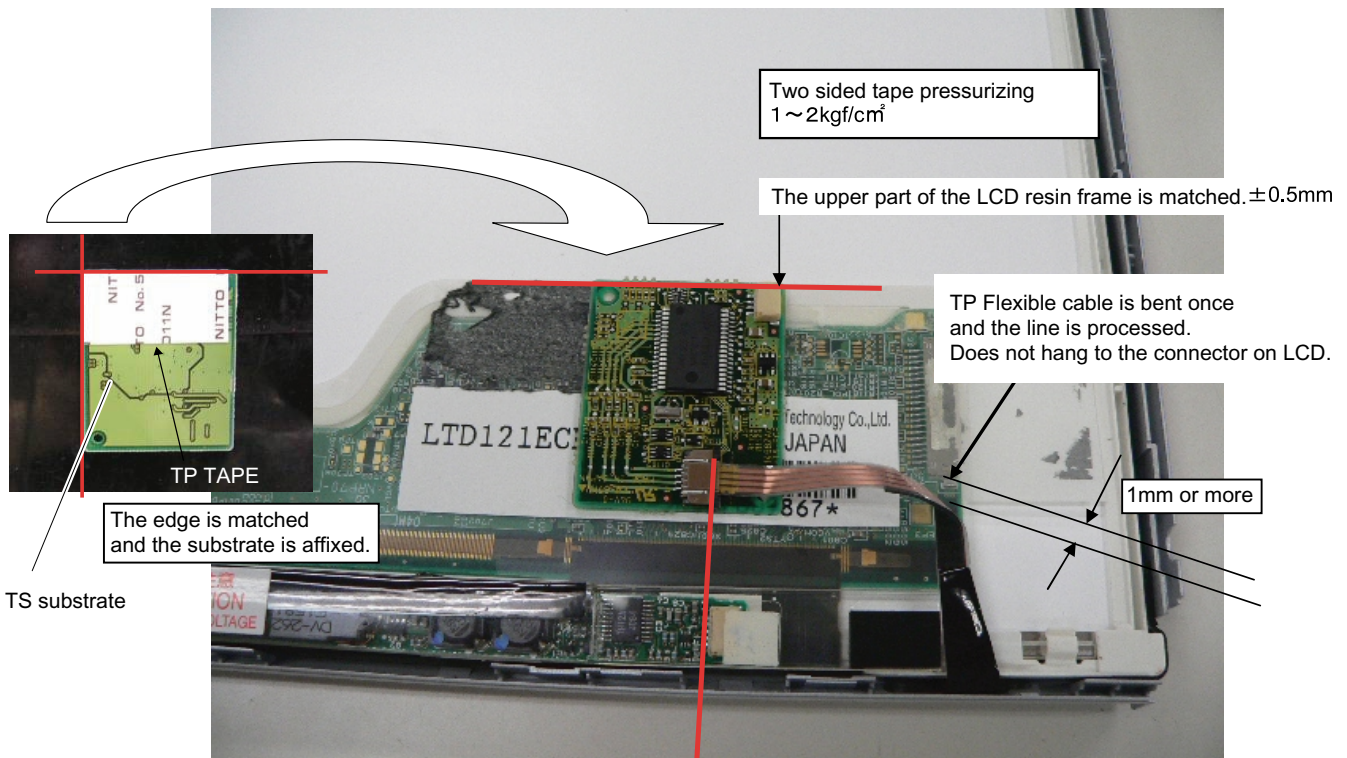

A Flexible cable connector right edge of the control substrate is matched to the inverter connector left end. $\pm 1.0\text{mm}$

9.3.2.11. Line processing LCD cable (2)

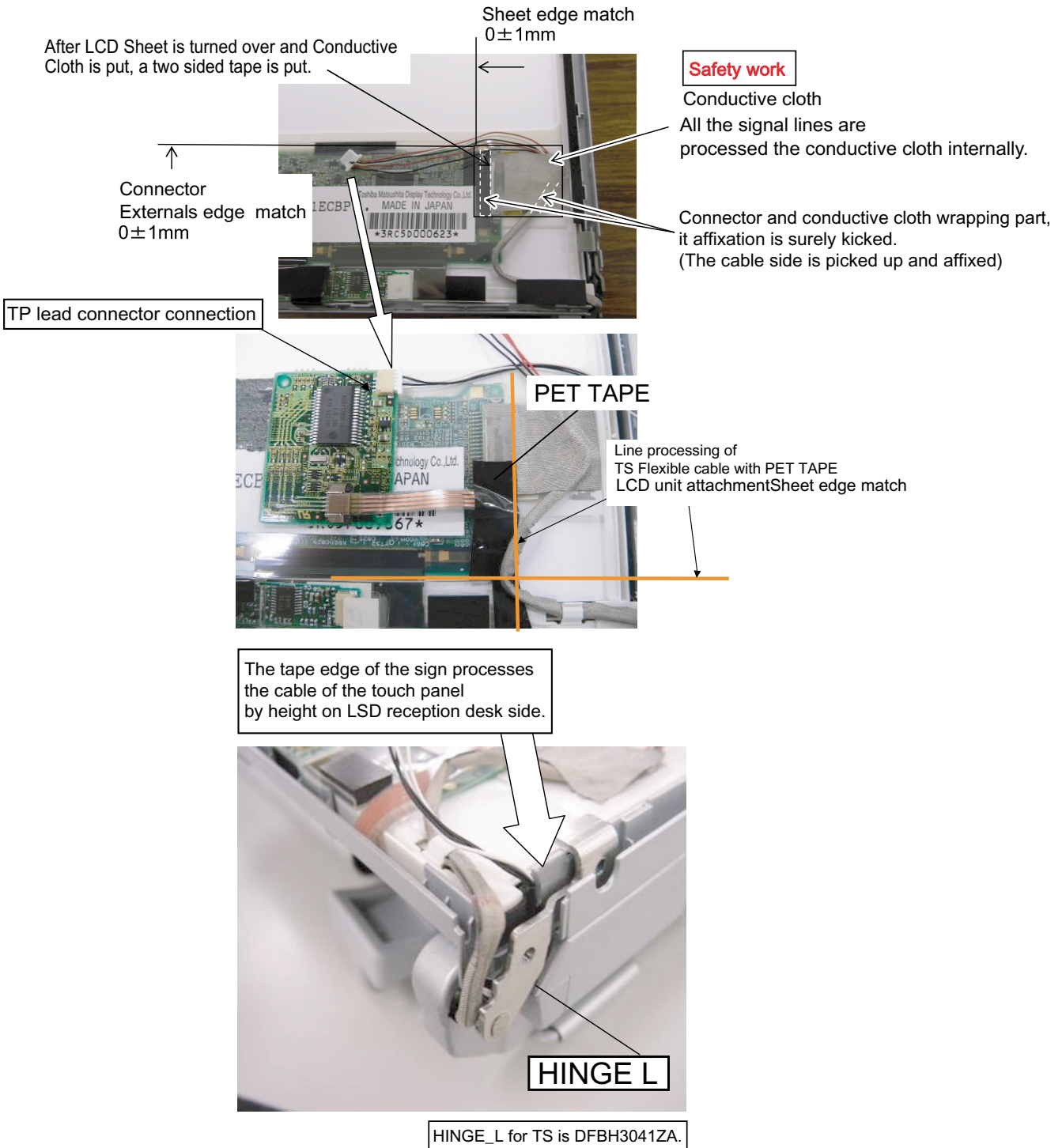

The built-in order ①-1

The built-in order ①-2

Safety work

The cable is prevented from coming in succession mutually. (10MM × 50M/roll)

The tape is distributed at the center and pasting applying.

Safety work

The cable is prevented from running aground on the cushion.

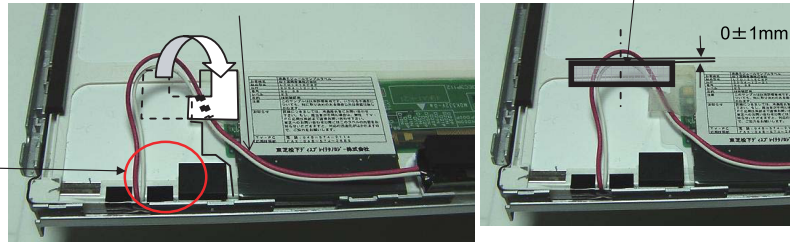

The built-in order ②

The remainder is put on the hinge side.

Put on the hinge surely.

Gasket Cloth

Externals match of reflector Management size : 0 ± 1mm

Hinge-R

Put the reflector part surely.

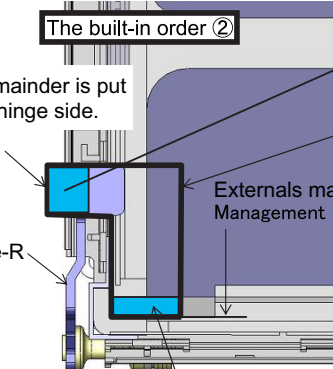

The built-in order ③

LCD Damper C

Externals match of plinth Management size : 0 ± 1mm

LCD Front is applied to the wall and pasting applying. Management size : 0 ~ 1mm

Edge match of lamp lead Management size : 0 ± 1mm

LCD Front is applied to the wall and pasting applying. Management size : 0 ~ 1mm

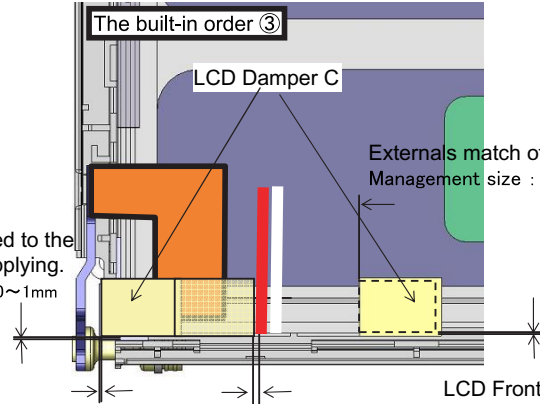

9.3.2.12. Putting Tape of LCD Cable

● Affixation of tape

DFHR3154ZA(10x10) seat putting from the inverter lead connector edge to the place of 100mm

Safety work

The cable is bundled this is prevented from parting.

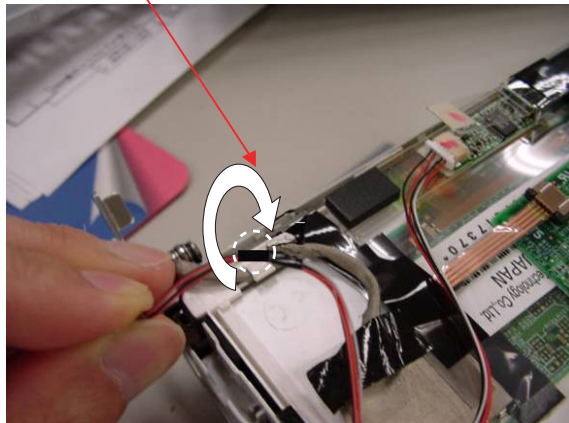
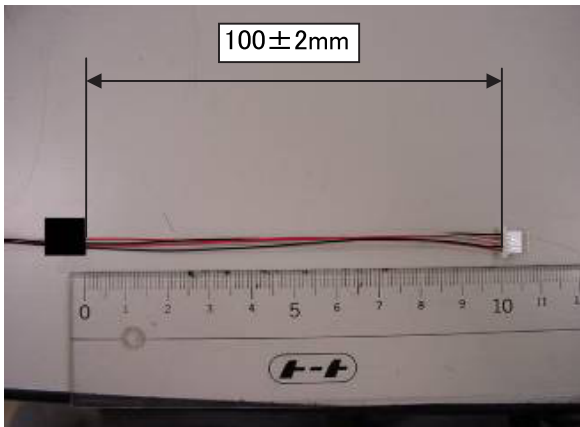

● Affixation of tape Rear Damper

Before affixing Rear Damper, do not come in succession in the TP clamping part.

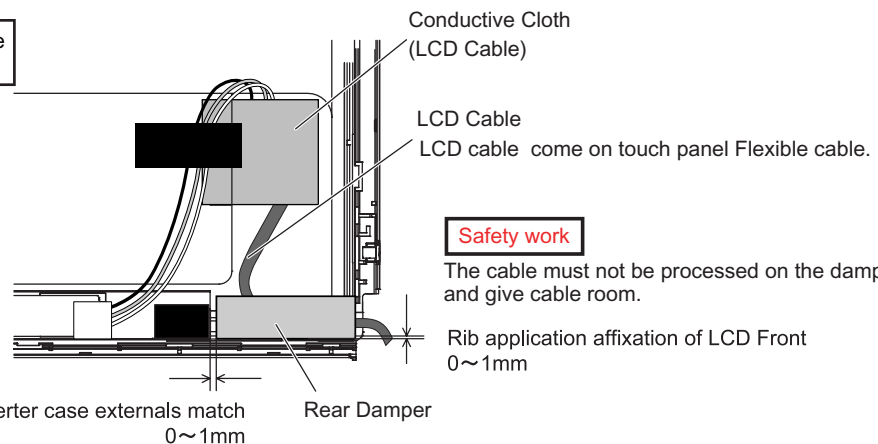
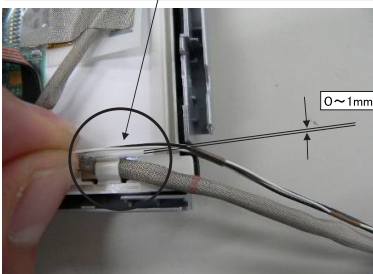

Safety work

The cable must not be processed on the damper, and give cable room.

● Affixation of PET Tape

- The cable must not be processed on the damper, and give cable room.
- Along the LCD module and put the LCD cable (Inverter part) with the PET tape.

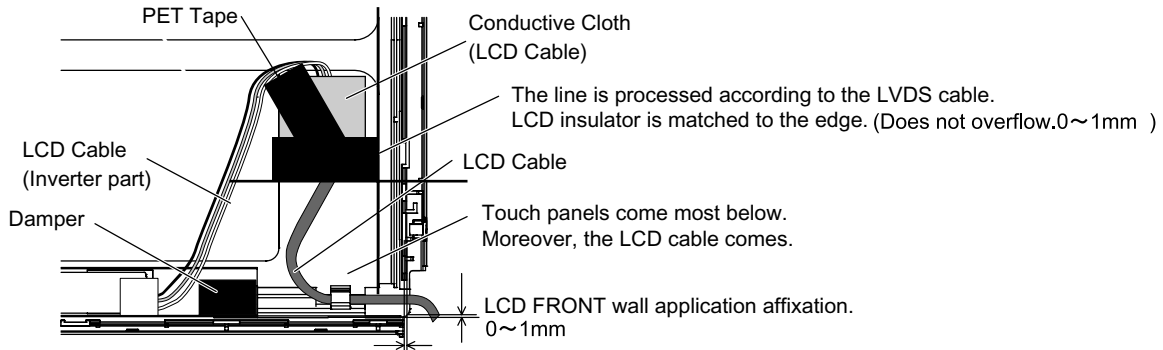

Safety work

The cable must not be processed on the damper, and give cable room.

FRAME externals are matched. 0~1mm

The line is processed according to the LVDS cable. The tape is hit to the top of the insulation seat, and it is matched to a right edge. (Does not overflow. 0~1mm)

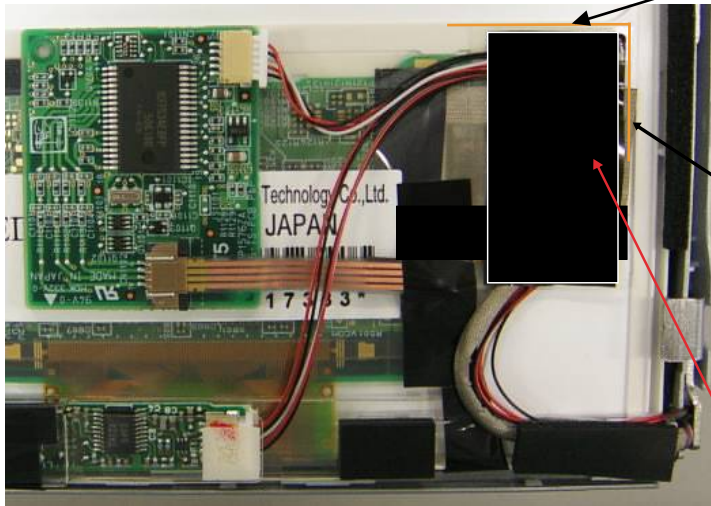

Safety work

PET Tape is put on the touch panel. PET Tape, and, does not overflow from side.

PET Tape

9.3.2.13. Assembly of the Pen Holde

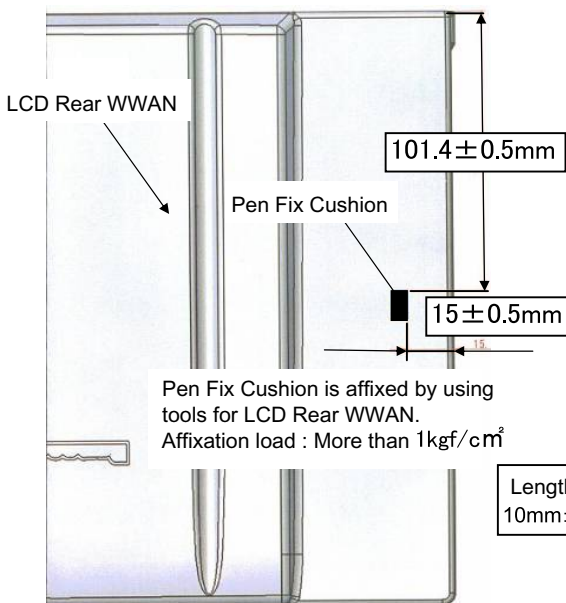

■ Pen Fix Sheet affixation specification

Affixes Pen Fix Sheet along Pen Fix Cushion after Pen Fix Cushion is affixed

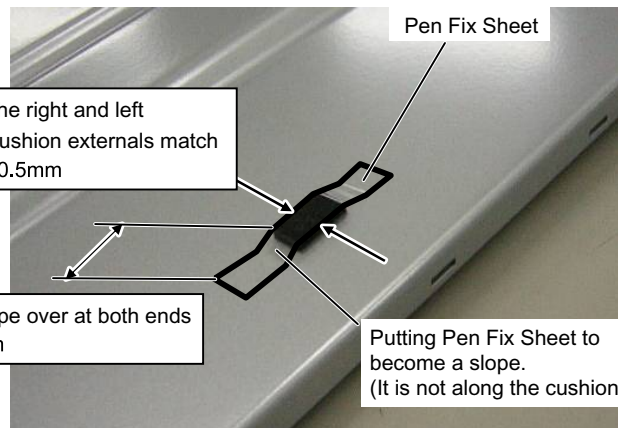

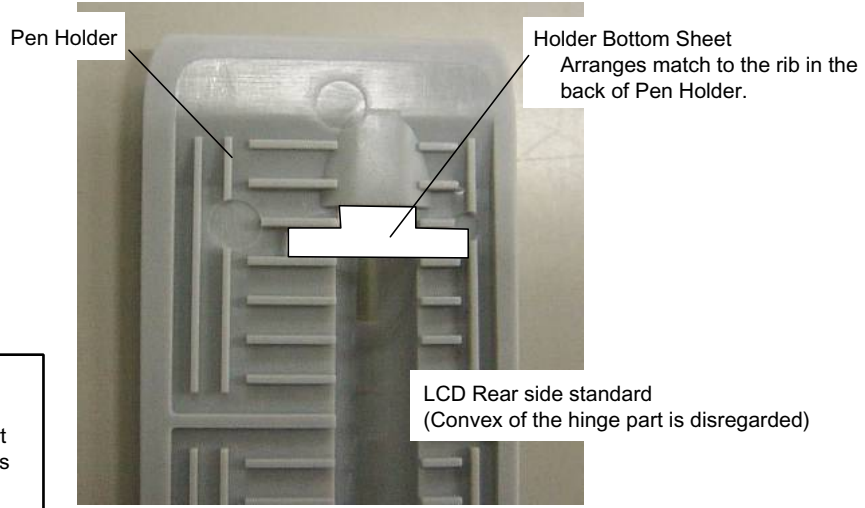

Affixeson Holder Bottom Sheet.
The hole of the tape is matched to the hollow of the insertion part of the pen. Affixes from externals internally by 0.5mm or more.

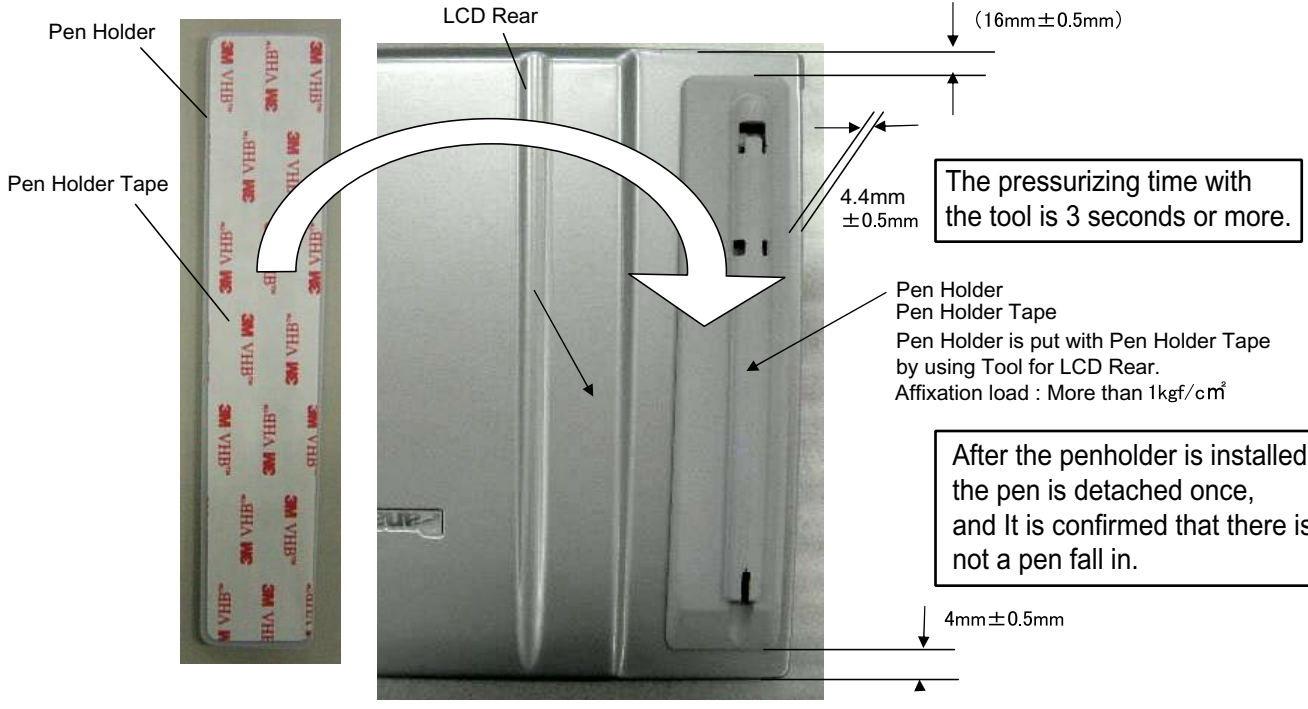

9.3.2.14. Putting LCD Rear Cushions

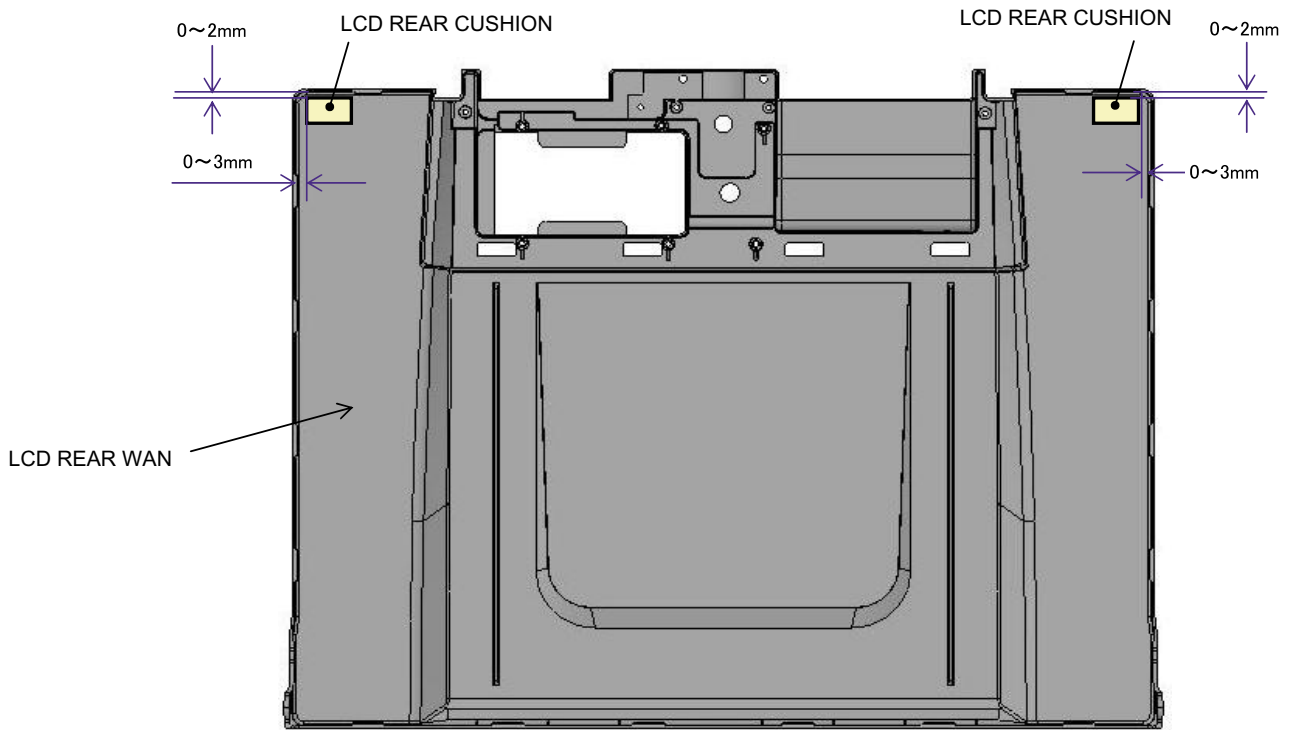

9.3.2.15. Assembly of the WM Cable

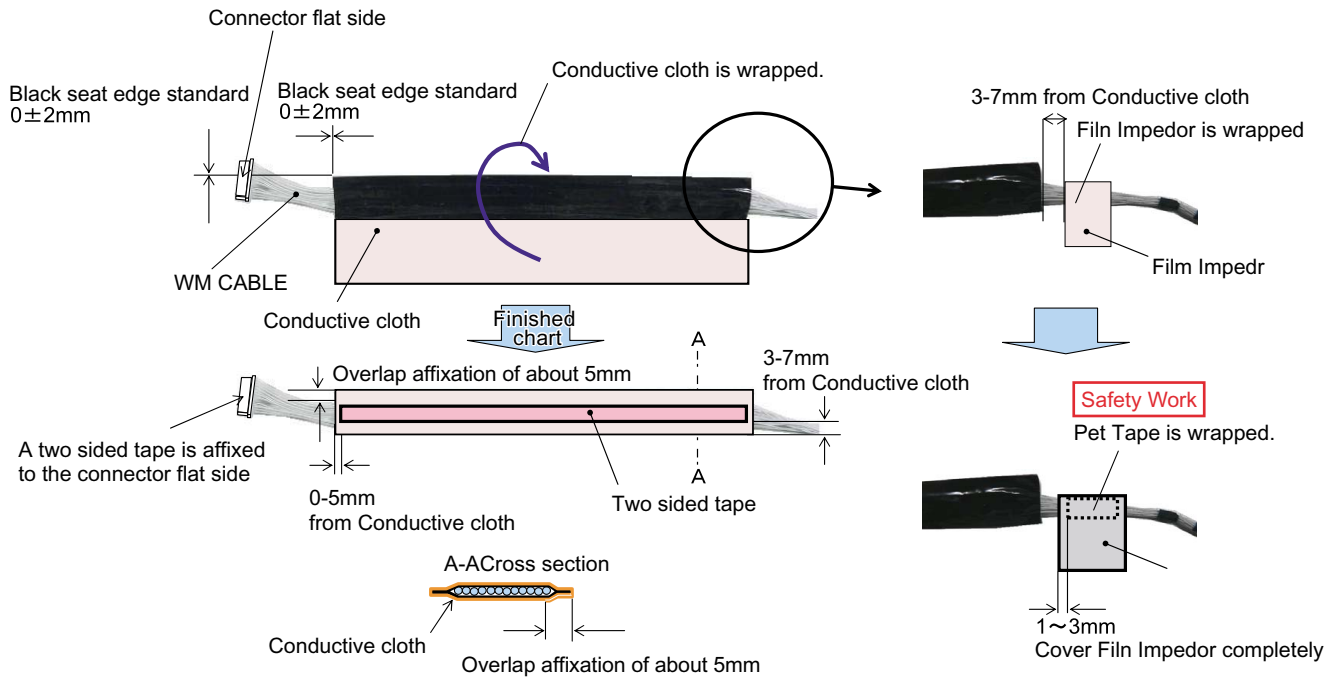

9.3.2.16. Assembly of the WWAN Board

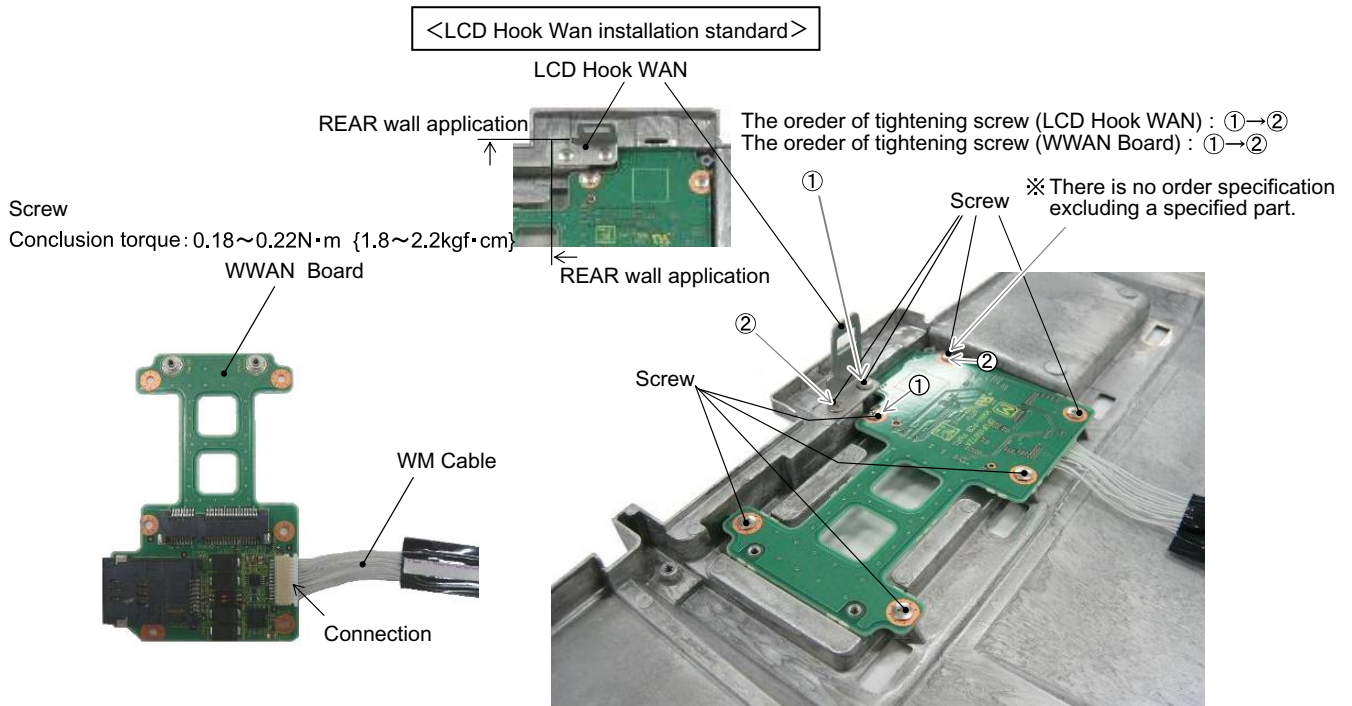

9.3.2.17. Putting Tapes for WM Cable

● Affixation of Conductive cloth

<Figure 1>

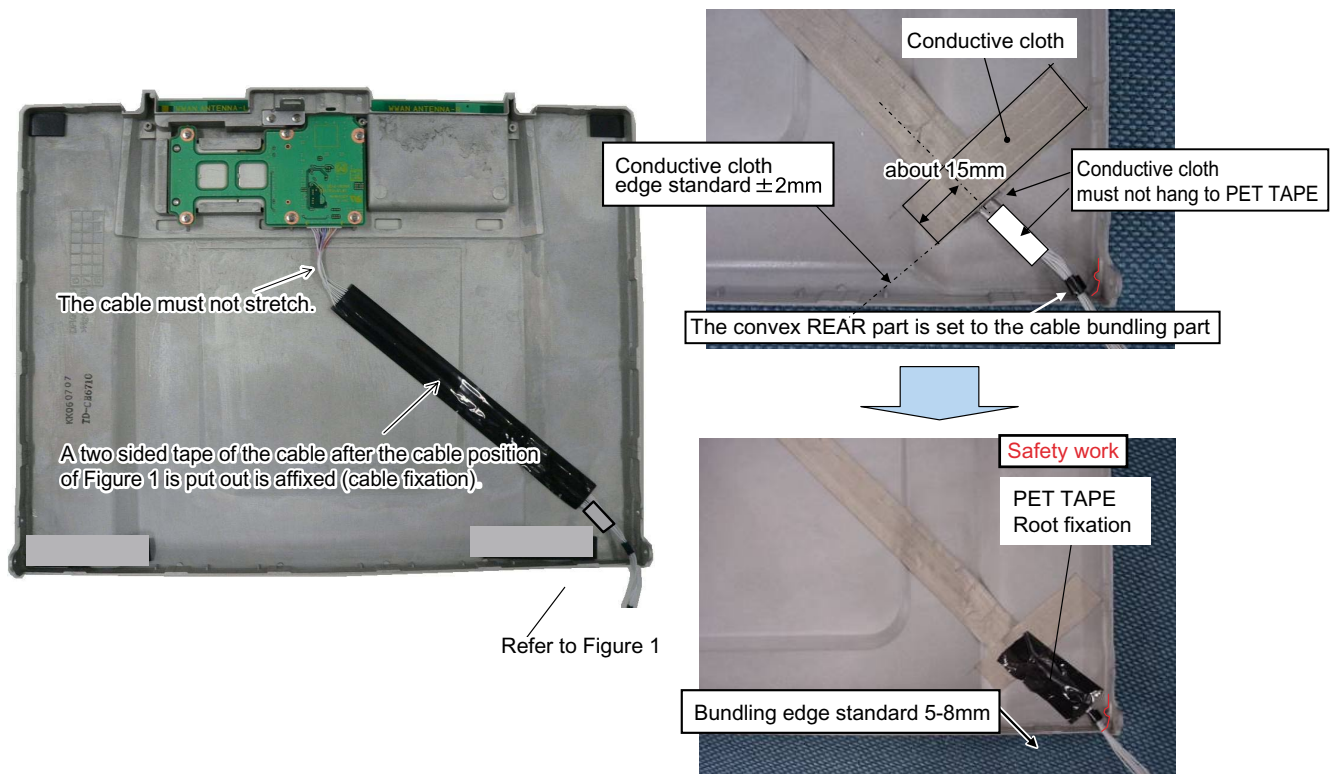

●PET TAPE assembly

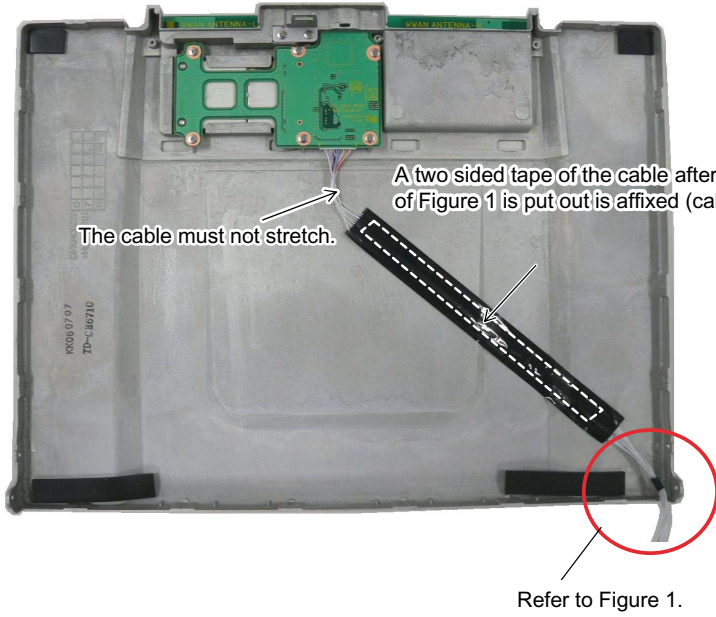

<Figure 1. >

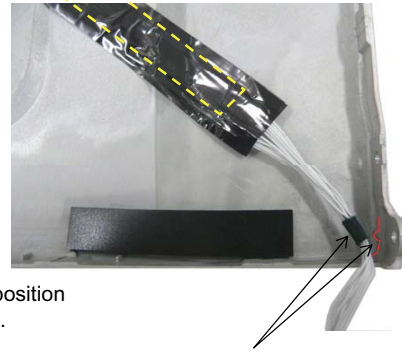

The convex part is matched to a black tape.

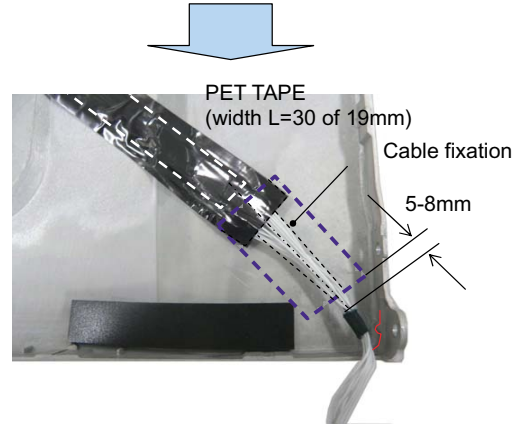

9.3.2.18. Assembly of the WWAN Antenna Board (MAIN), (SUB)

The coaxial cable connector is processed in the corner hole of the substrate

Safety work

After the cable is processed to the ditch of REAR, CABLE FIXED SHEET is affixed

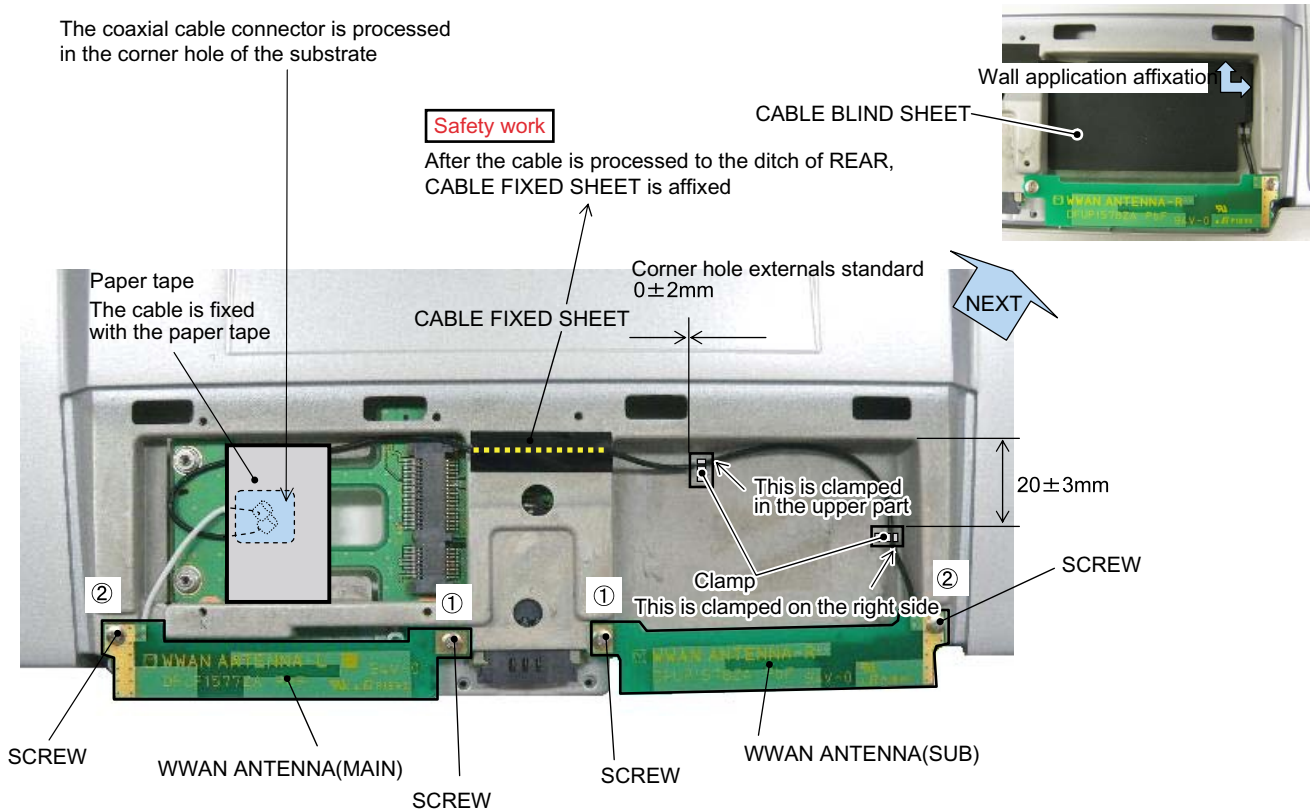

SCREW
Conclusion torque:
0.18~0.22N·m {1.8~2.2kgf·cm}

The order of tightening screw: ①→②

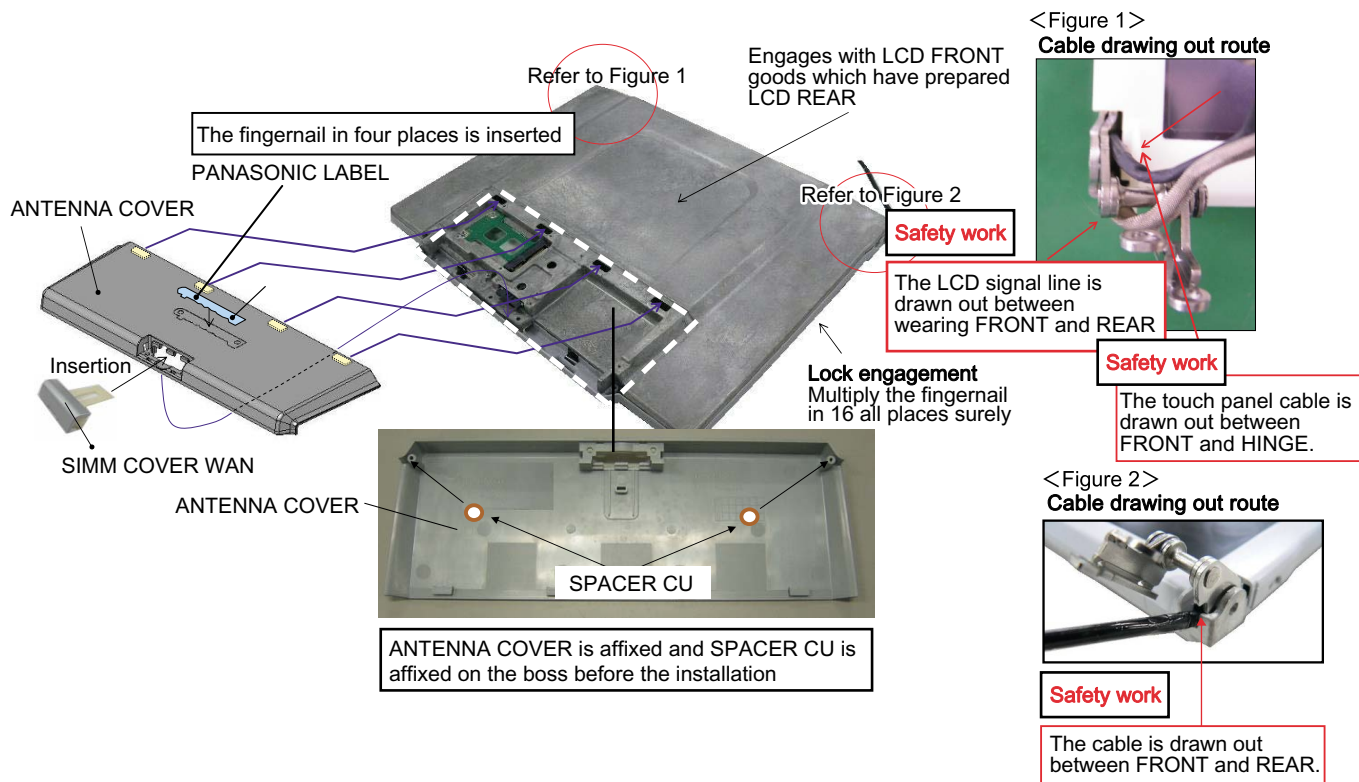

9.3.2.19. Assembly of the Hinge Cover (L), (R)

(Note)

- The screw cannot use the fixed lock medicine repeatedly for use. Exchange for the new article when tightening again
- Tighten the back pushing when you tighten the screw. (cover space generation prevention)

The order of tightening screw: a→b
Screw : DRHM0076ZA

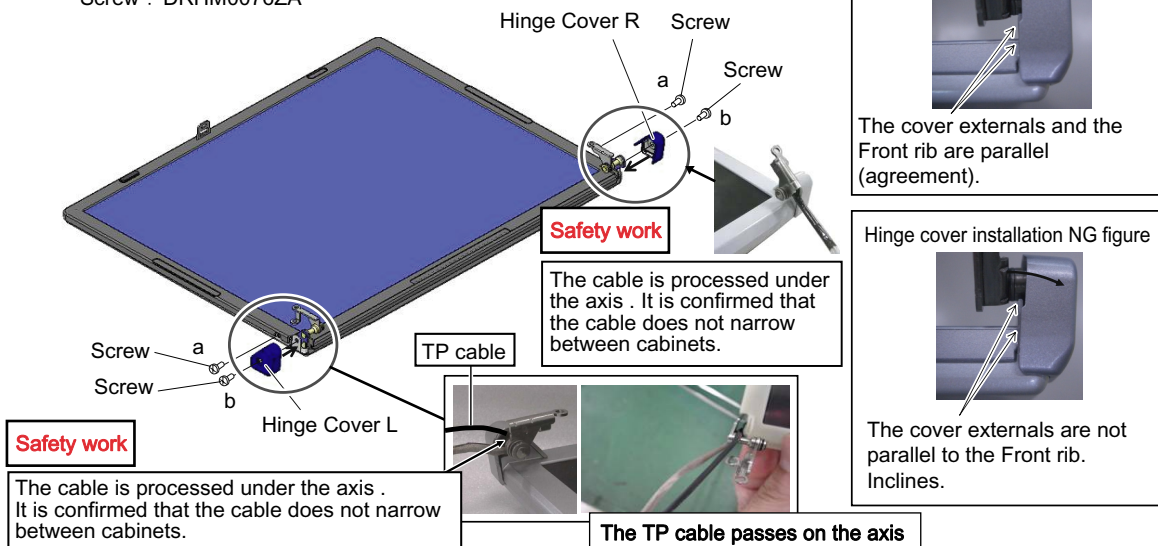

9.3.2.20. Putting Productive Film

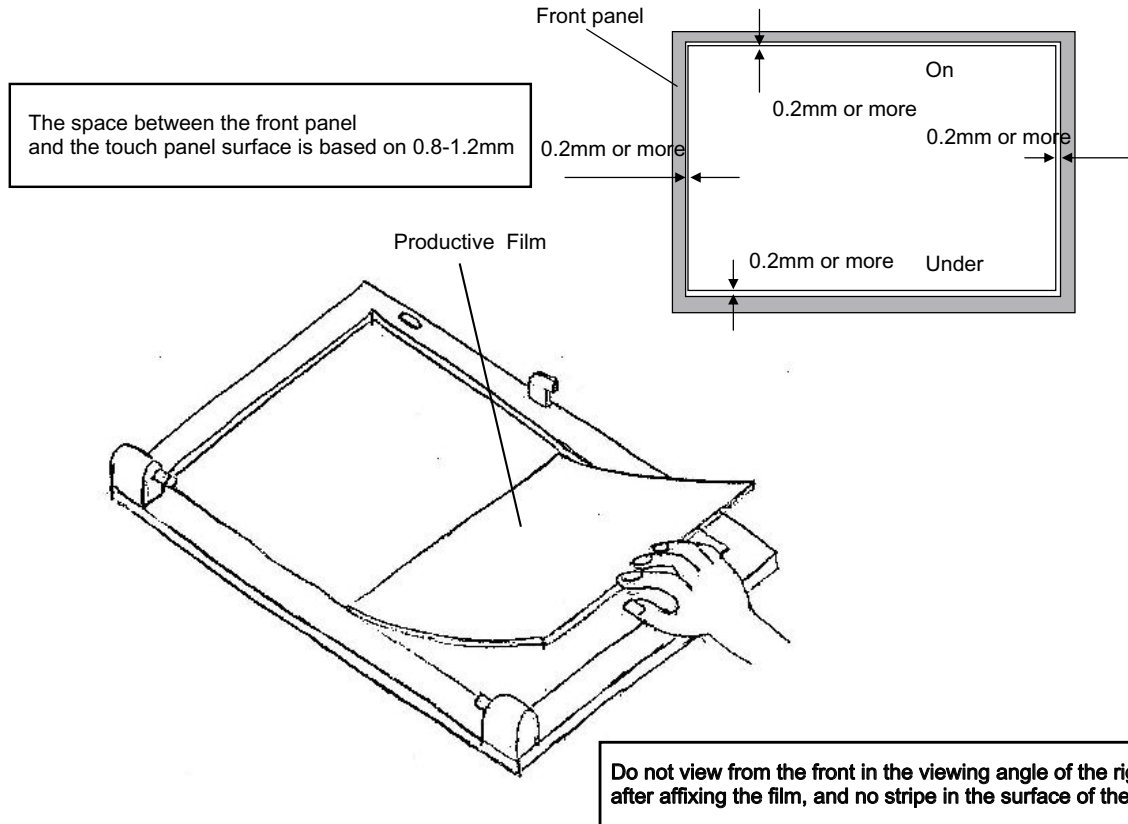

9.3.3. Assembly knowhow of the Main Board

9.3.3.1. Putting tapes for Memory Sheet of top side

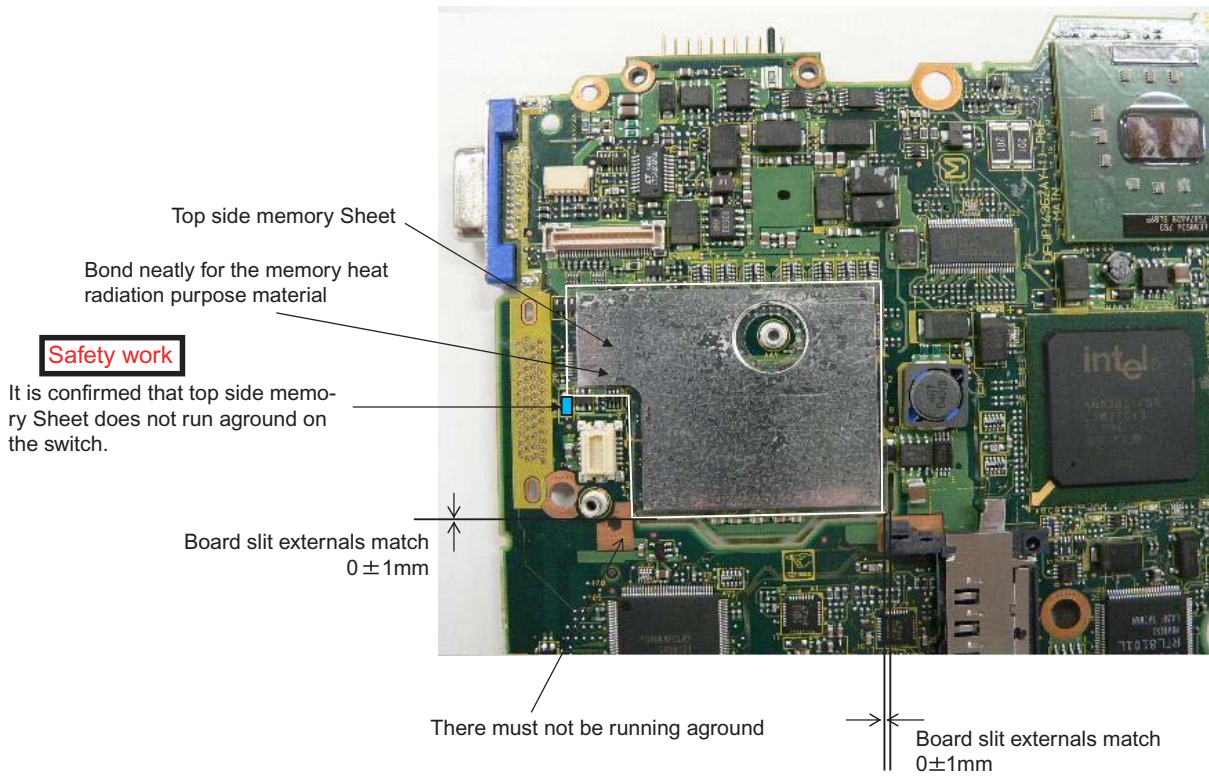

• Be sure to bond neatly for the memory heat radiation purpose material

9.3.3.2. Assembly of the MDC MODEM

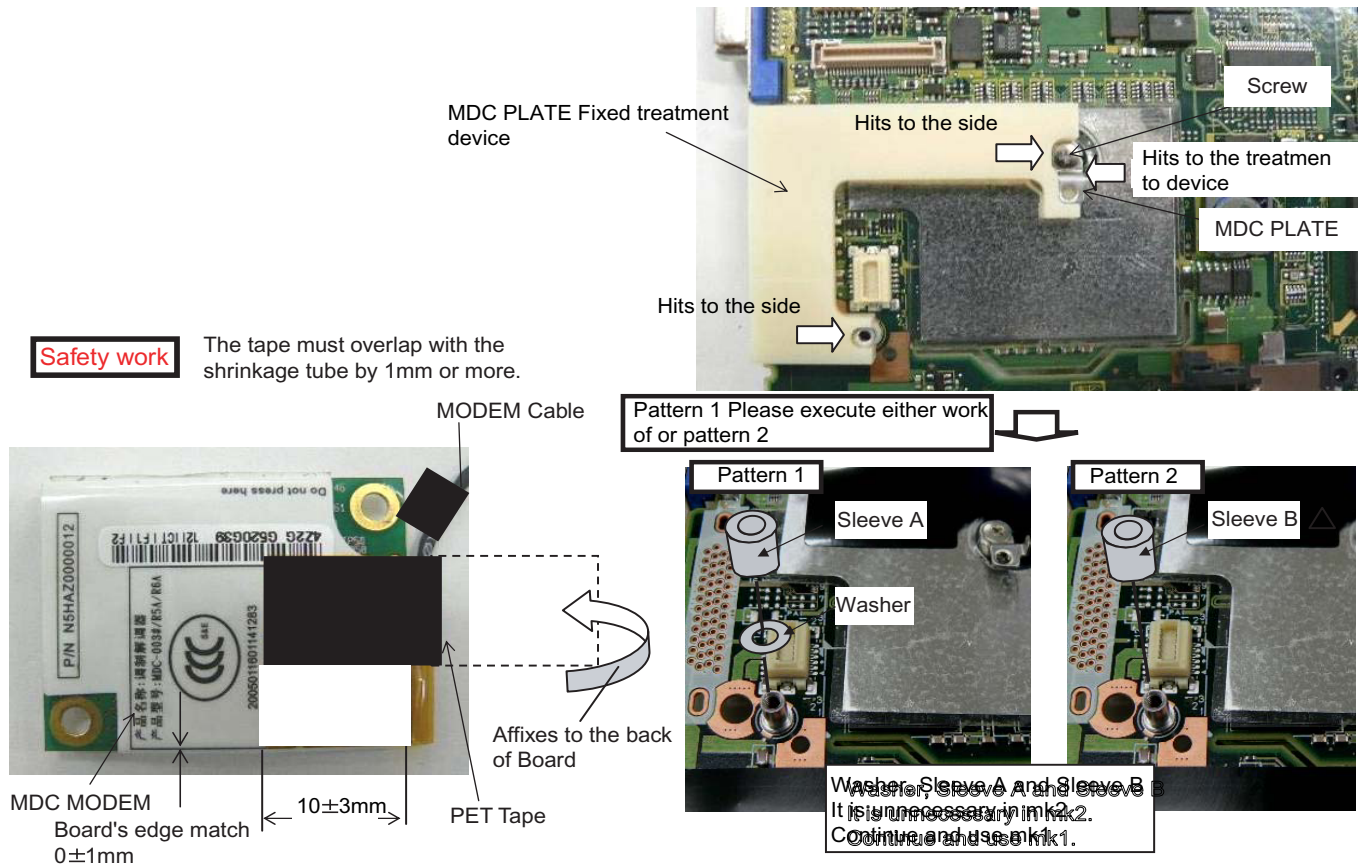

9.3.3.3. Putting PET tapes

- The order of tightening screw : a→b
- Screw : DXQT2+D25FNL

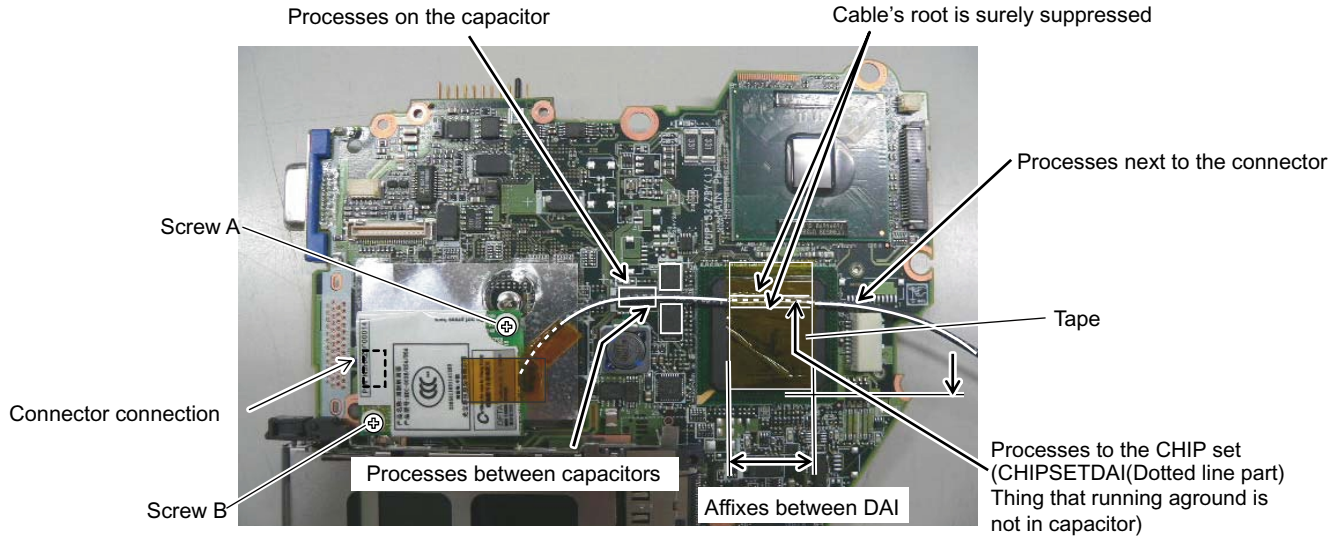

【Attention】

- Modem Cable must install MDC MODEM in Main Board after connects with MDC MODEM.
- Do the machine screw tightening in Main Board by tightening the hand. Moreover, note that receives by the hand, and Main Board is not curved on the other side of Main Board of the machine screw tightening part.
- ※ Solder crack prevention by Main Board spring

(Attention)

Affixation load of affixation thing not instructed : More than 1kgf/cm²

- Corner hole part DAI of the CIP set is matched and affixes Affix without running aground on CPU DAI.

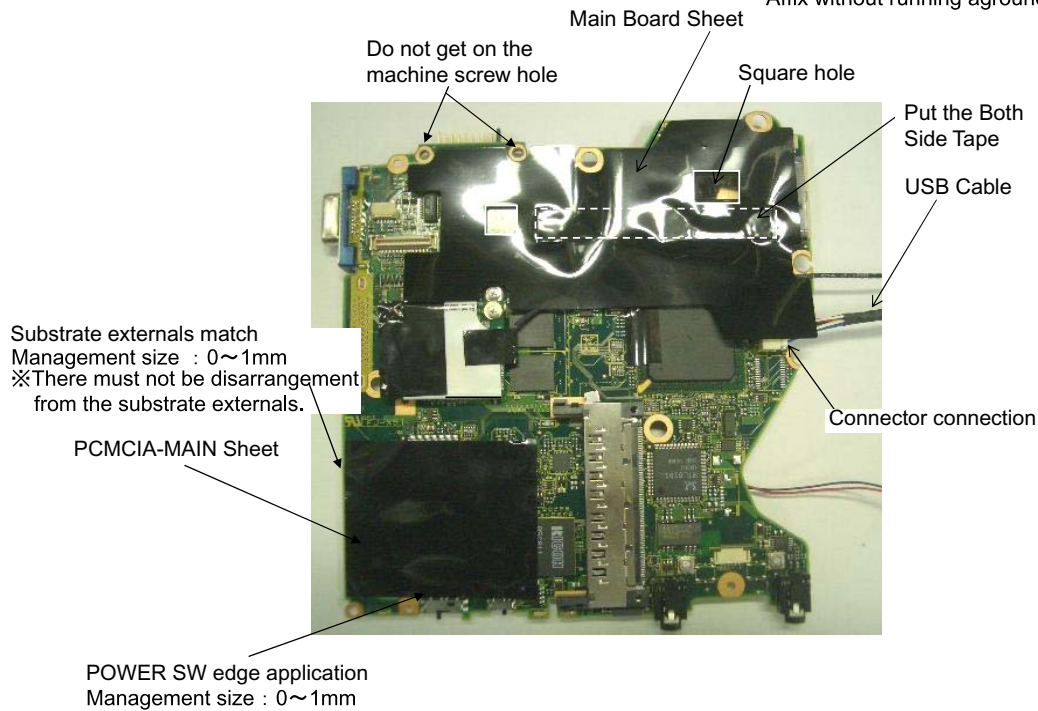

<Attention>

Execute after setting the substrate in the receiving treatment device when working.

9.3.3.4. Assembly of the PCMCIA Ejector

(Attention)

Affixation load of affixation thing not instructed : More than 1kgf/cm²

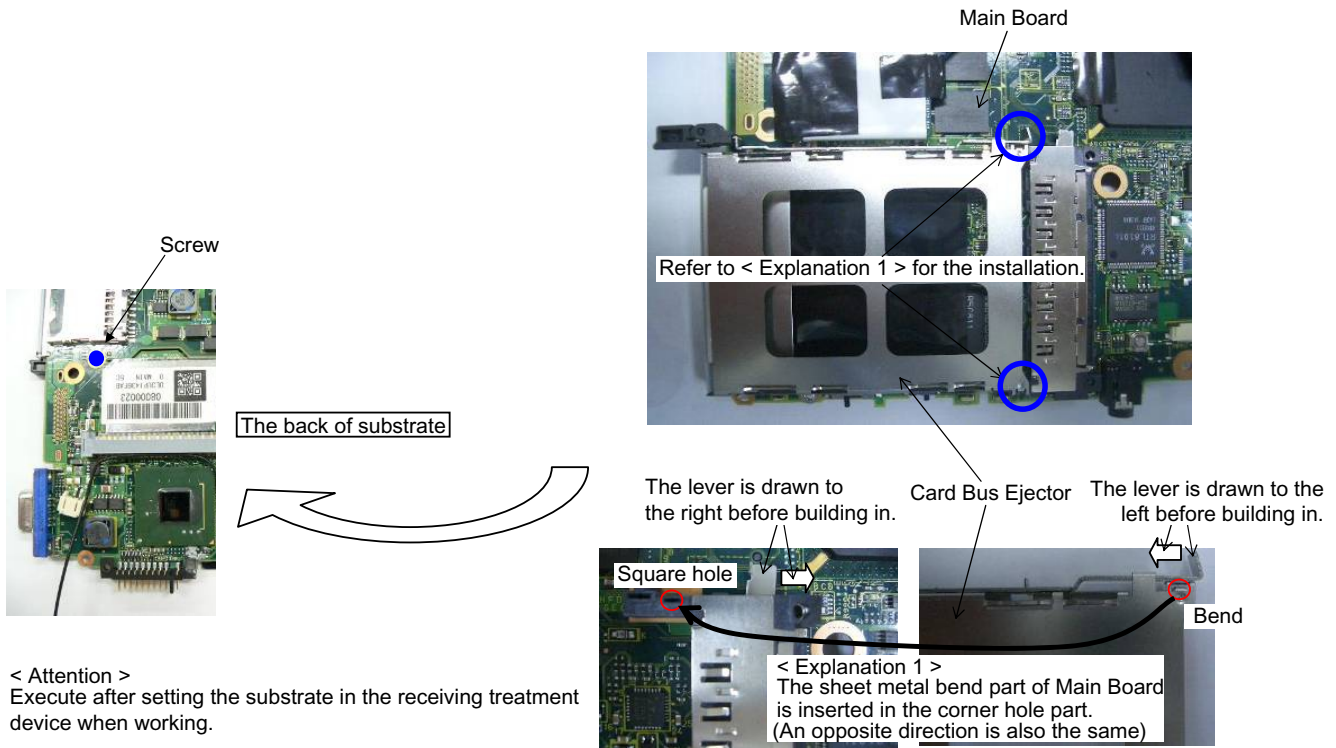

< Attention >
Execute after setting the substrate in the receiving treatment device when working.

● Screw fixation of PCMCIA Ejector

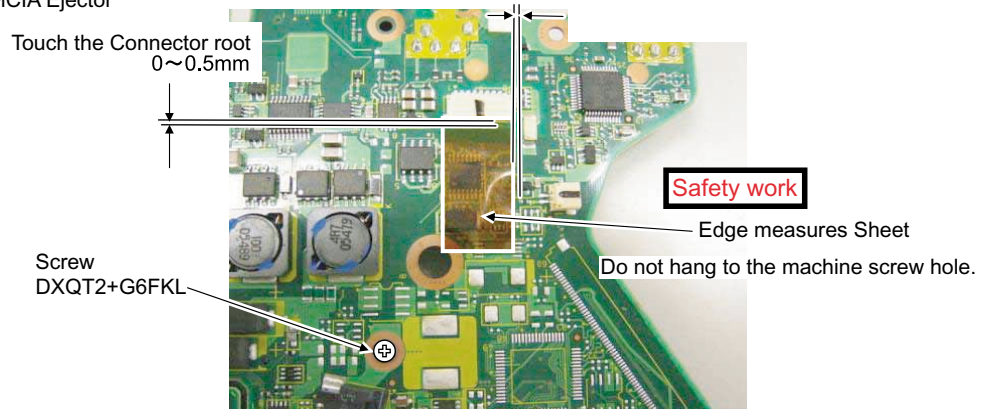

9.3.3.5. Assembly of the LAN Cable

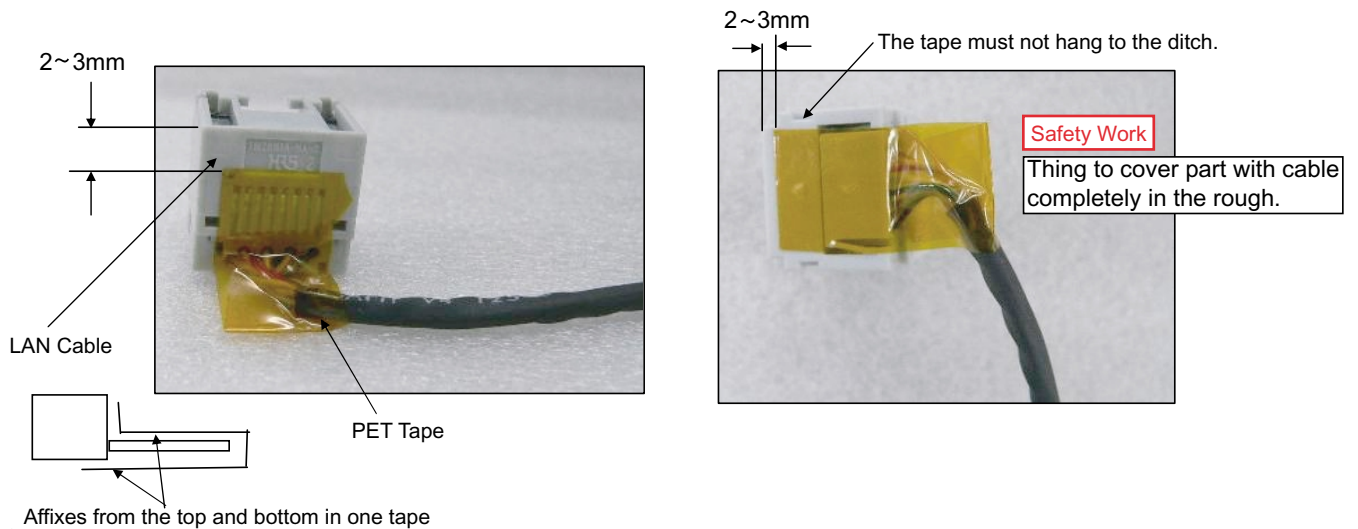

9.3.3.6. Line processing LAN cable

Thing to process modem cable previously

1. The modem cable is processed to the bottom ditch part.

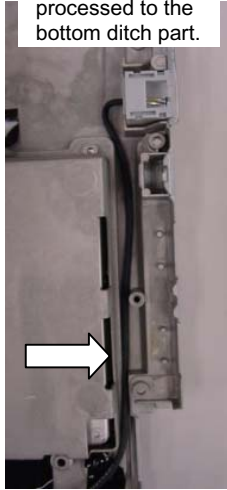

2. LAN cable afterwards is processed up



(Safety work)

Affixation load of affixation thing not instructed : More than 1kgf/cm²

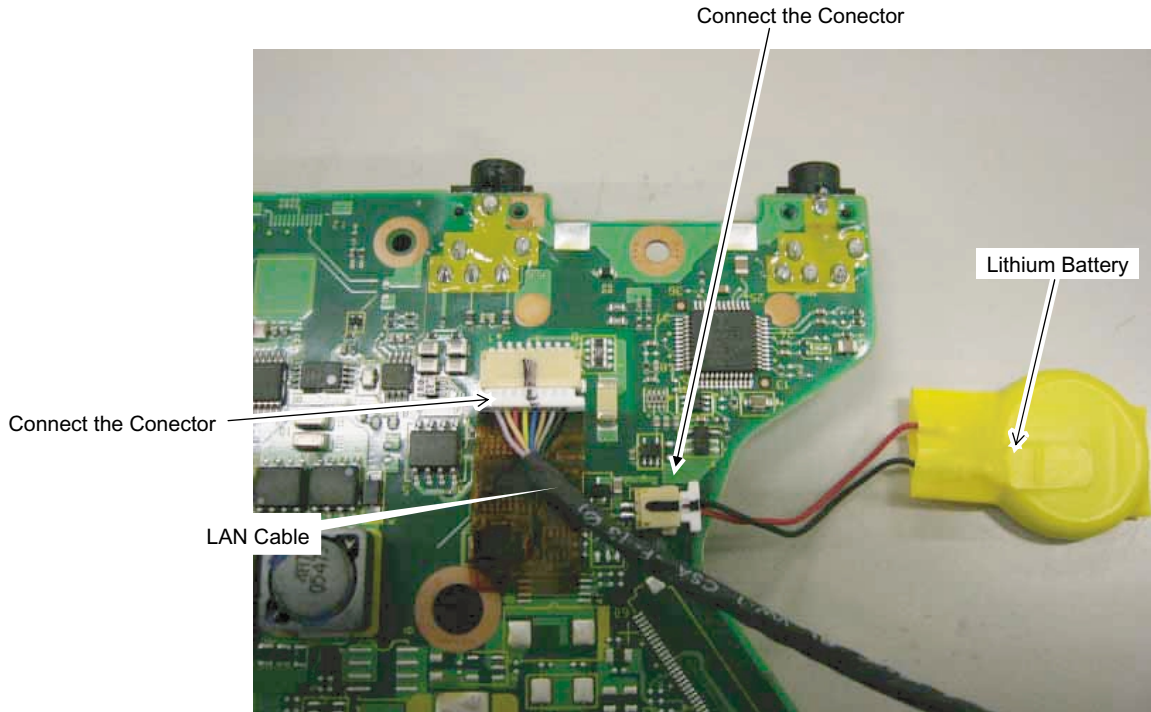

9.3.3.7. Assembly of the W-LAN Module / Putting Memory Sheet

(Attention)
Affixation load of affixation thing not instructed : More than 1kgf/cm²

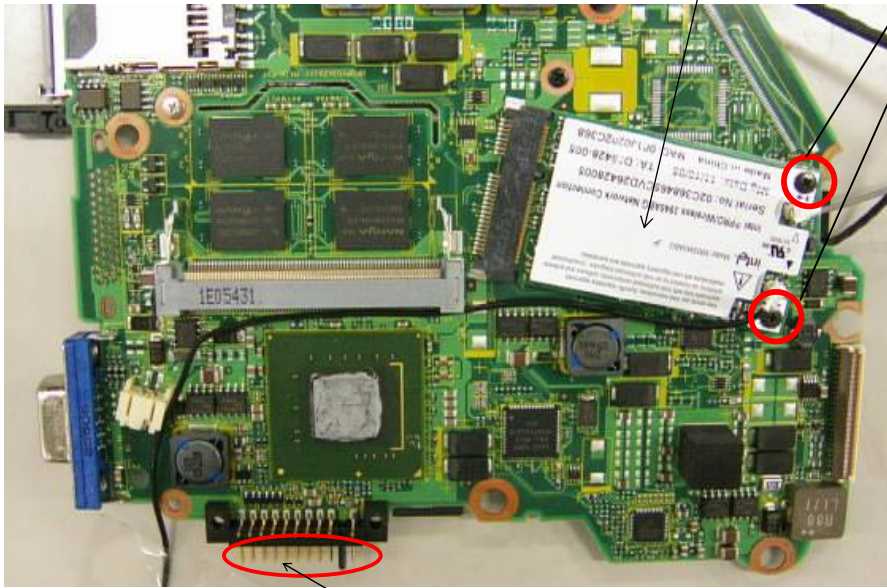

W-LAN
MODULE

Screw
DXQT2+D25FNL

Spreads on the terminal BATT
(It is one blowing to the range)

< Attention >
Execute after setting the substrate in the receiving
treatment device when working.

(Attention)
MEMORY HEAT Sheet and B/C Label Affixation load : More than 1~2kgf/cm²

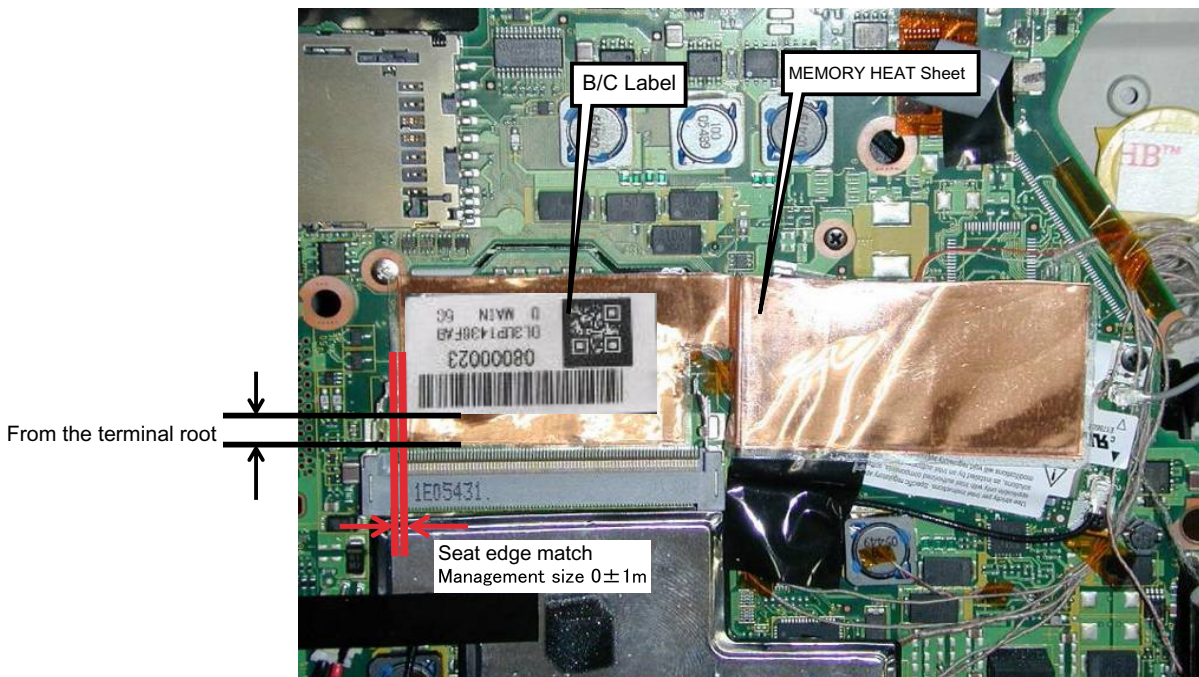

B/C Label

MEMORY HEAT Sheet

From the terminal root

Seat edge match
Management size 0±1m

<Attention>
Execute after setting the substrate in the receiving treatment device when working.

9.3.3.8. Putting Sheets

(Attention)
Affixation load of affixation thing not instructed : More than 1kgf/cm²

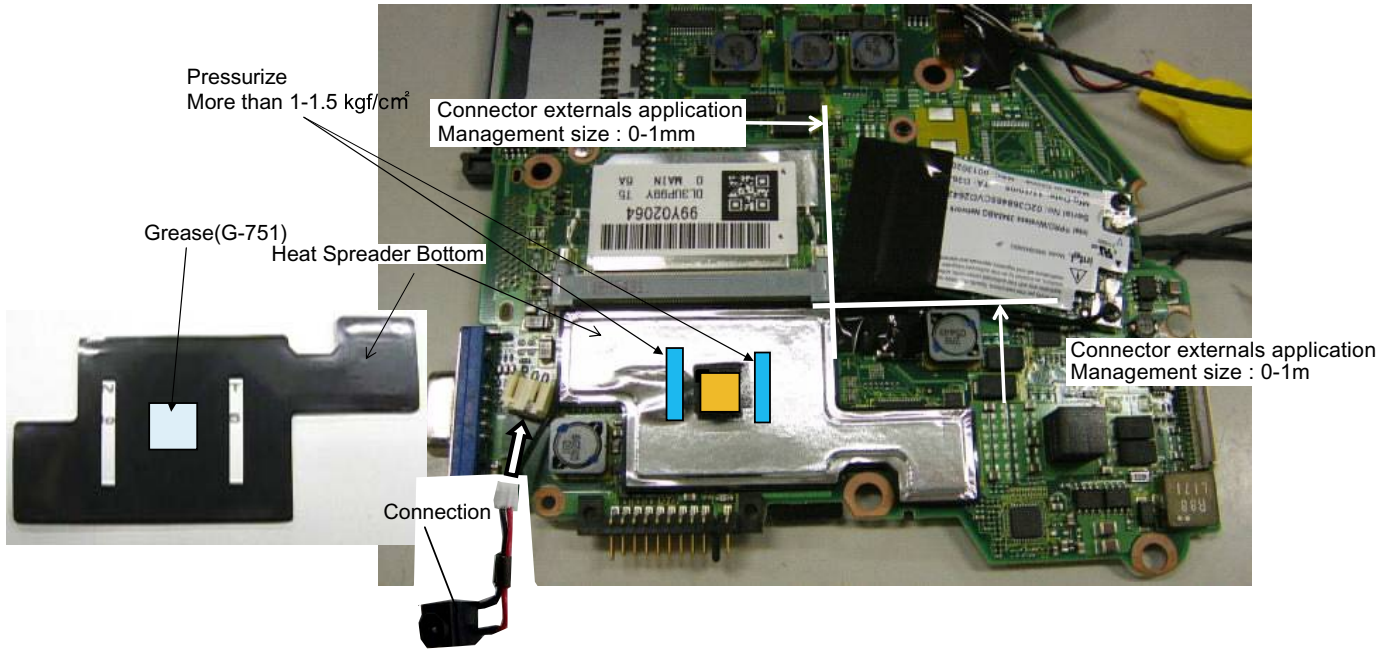

<Attention>
Execute after setting the substrate in the receiving treatment device when working.

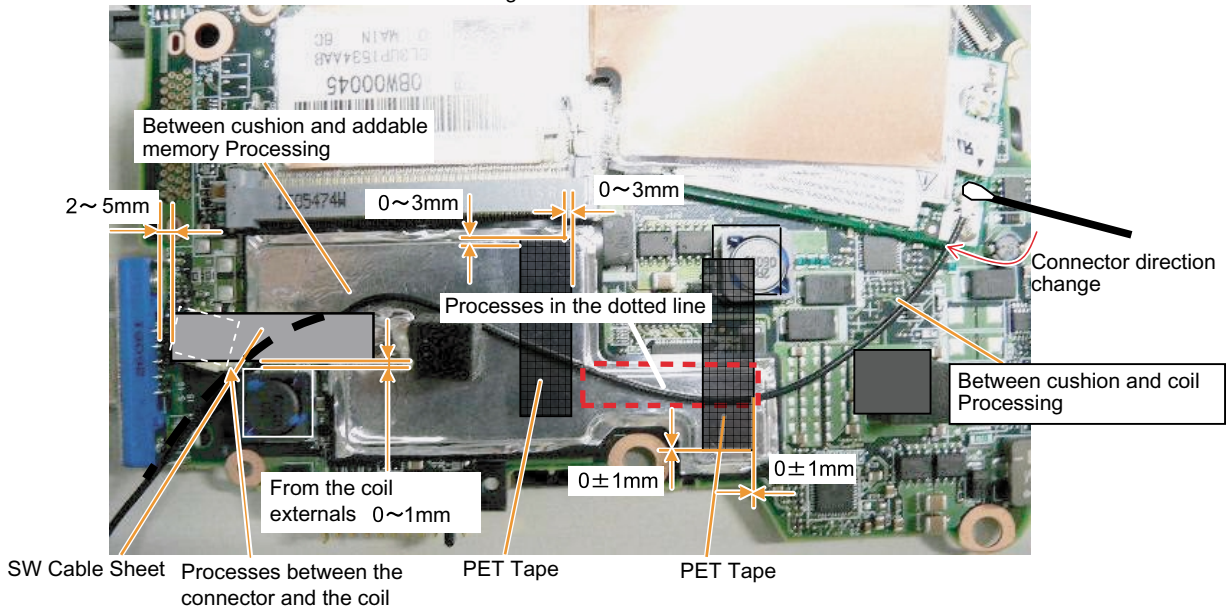

The HEAT cushion is affixed in the place without the chip wireless LAN connector sideward.
Do not run aground in the chip on side.
It is unquestionable for the inclination as long as does not run aground.

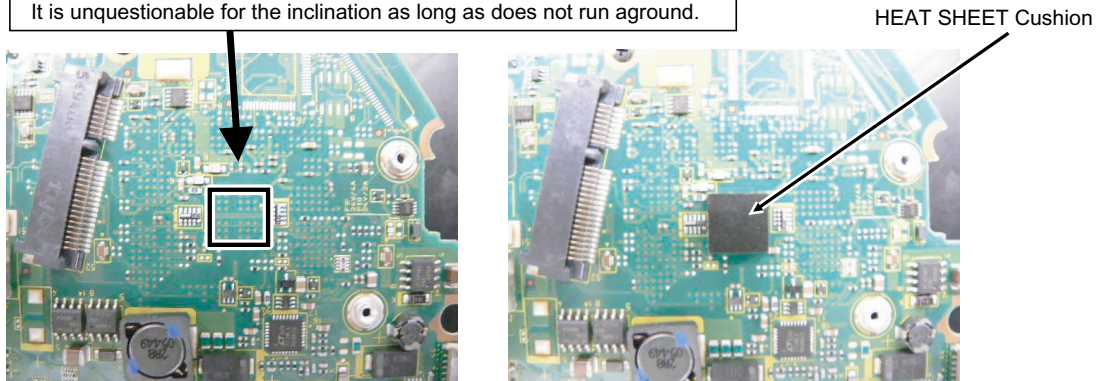

9.3.3.9. Assembly of the W-LAN Sheet

< preparation of W-LAN Sheet >

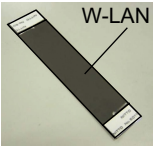

W-LAN Sheet



Runs side by side.

The cutting lack part is inserted, and puts into the state of the roll.

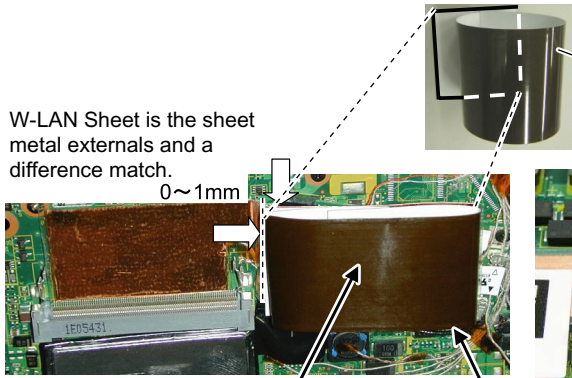

W-LAN Sheet

W-LAN Sheet is the sheet metal externals and a difference match.

0~1mm

Sheet is lightly held by the finger and the fold habit is applied.

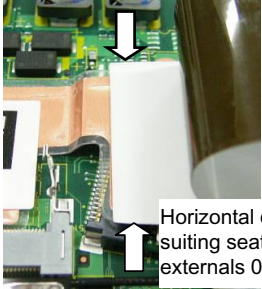

Horizontal direction is a suiting seat copper part externals 0-1mm.

The both sides tape flaking off paper is peeled off and affixes.

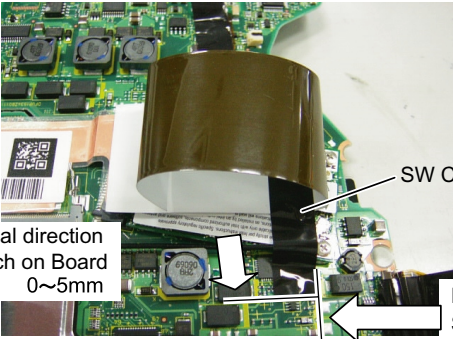

SW Cable Sheet

Vertical direction
Chip bottom match on Board
0~5mm

Horizontal direction
Silk line match on Board
 ± 2 mm

9.3.3.10. Assembly of the HDD FPC

CPU Cushion
Silk is made a sign and affixes

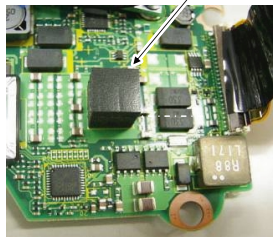
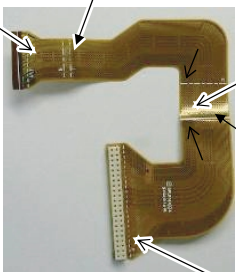
Valley case

Mountain case

HDD FPC

Mountain case

Valley case

Bends in the line of T mark.

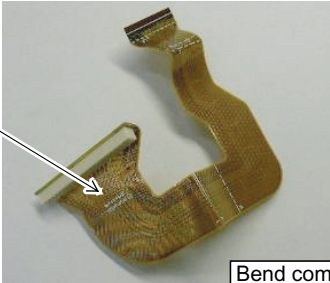

Bend completion chart

(Attention)

Affixation load of affixation thing not instructed : More than 1kgf/cm²

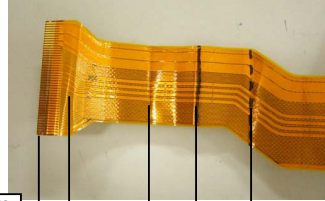

The white line is in respect **Mountain case 6mm**

The white line is in respect **Valley case 23mm**

Use the too **Mountain case 35mm**

Use the too **Valley case 45mm**

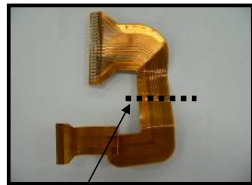

Valley case from white solid line on the back

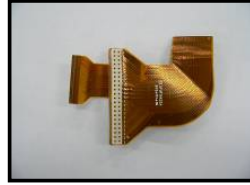

Bend completion chart

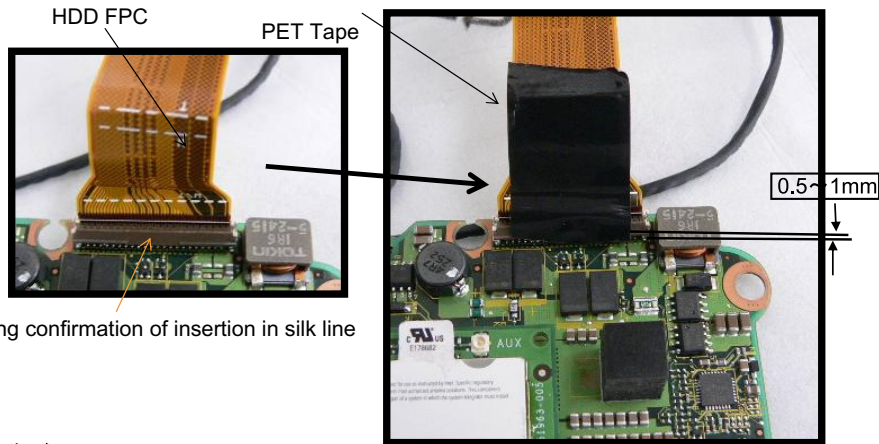

<Attention>

Execute after setting the substrate in the receiving treatment device when working.

9.3.3.11. Assembly of the DC-IN Cable

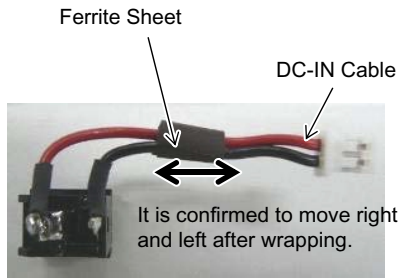

Safety work

Do not give the terminal the load while working.

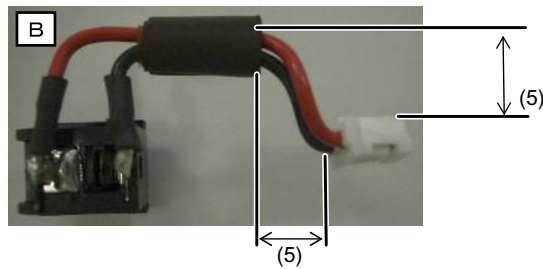
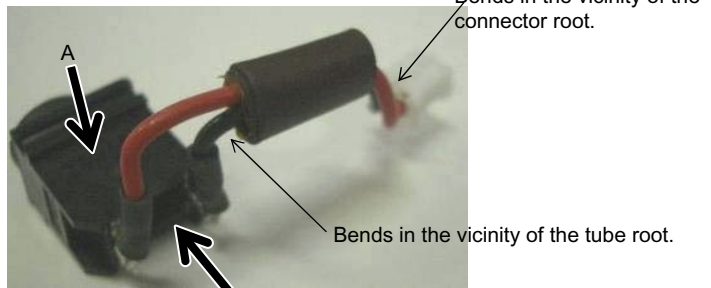
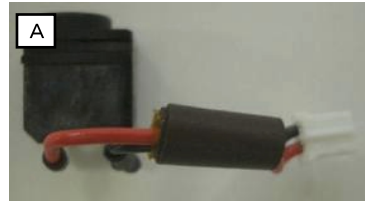

9.3.3.12. Setting the Main Board

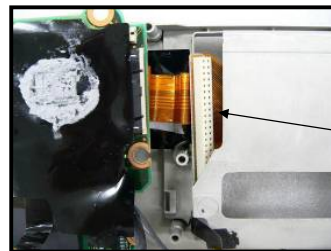

Insert HDD FPC in the opening of the bottom case while bent. No damage on the edge side to FPC.

Confirm, and install the turning off position (left side) Main Board's W-LAN SW.

Running around of shutter to bottom

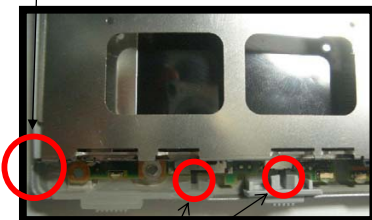

It is confirmed that the SW lever has been surely inserted in the ditch of the knob.

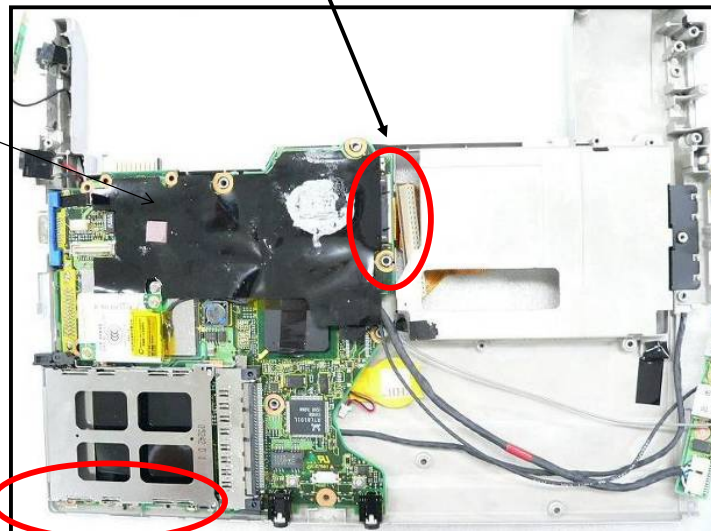

9.3.4. Assembly knowhow of the Top Case

9.3.4.1. Assembly of the Speaker

● Soldering of Speaker Cable

- Solder must not overflow Board externals.

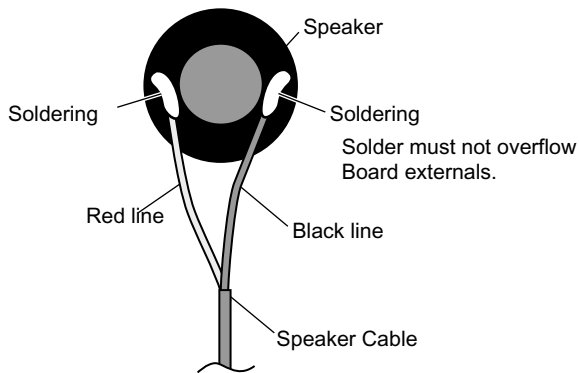

● Affixation of Speaker Ring

- Affix and kick according to the shape of the rib.
- Note not running aground in the rib.

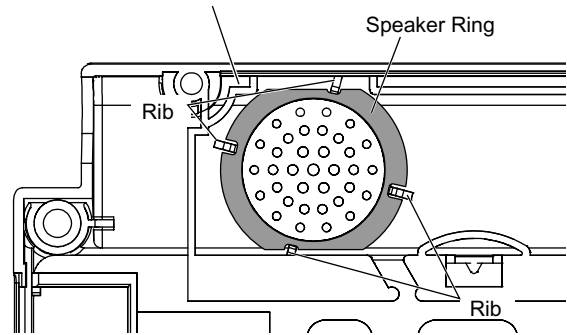

● Speaker installation

Safety work

- Marking of the safety distance confirmation is put. The people other than the speaker affixation worker execute the safety distance.

Safety work

- Secure 2mm or more for the space in each rib and the soldering part.

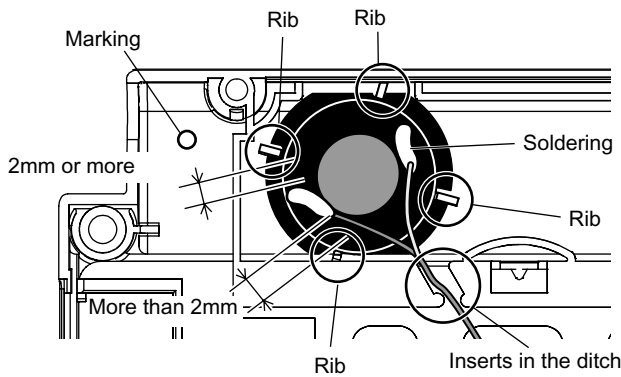

● Processing of Speaker Cable

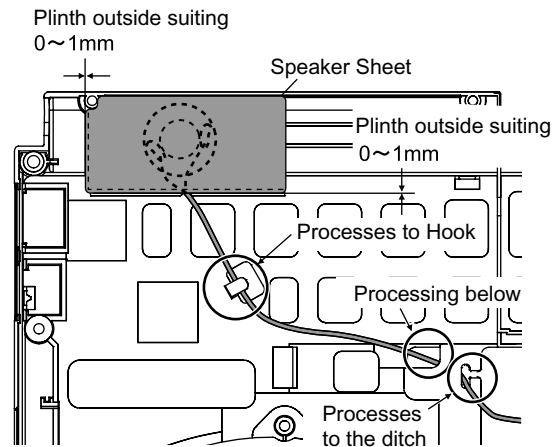

9.3.4.2. Line processing Speaker Cable and putting Speaker Sheet

< Speaker Cable processing >

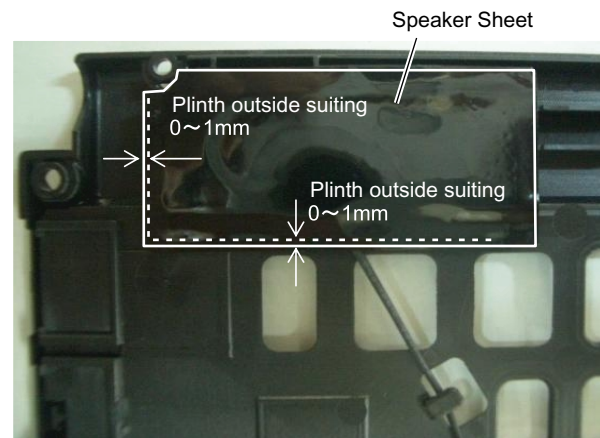
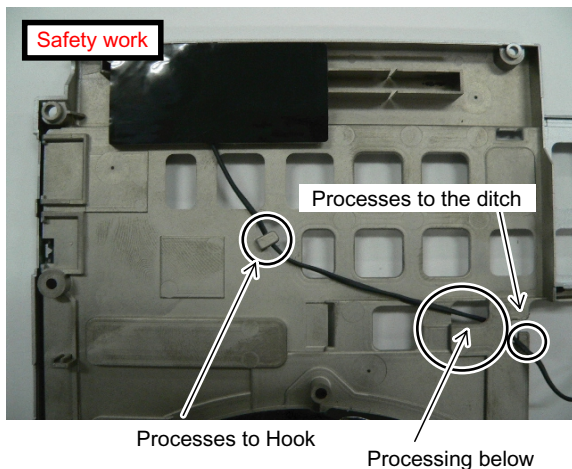

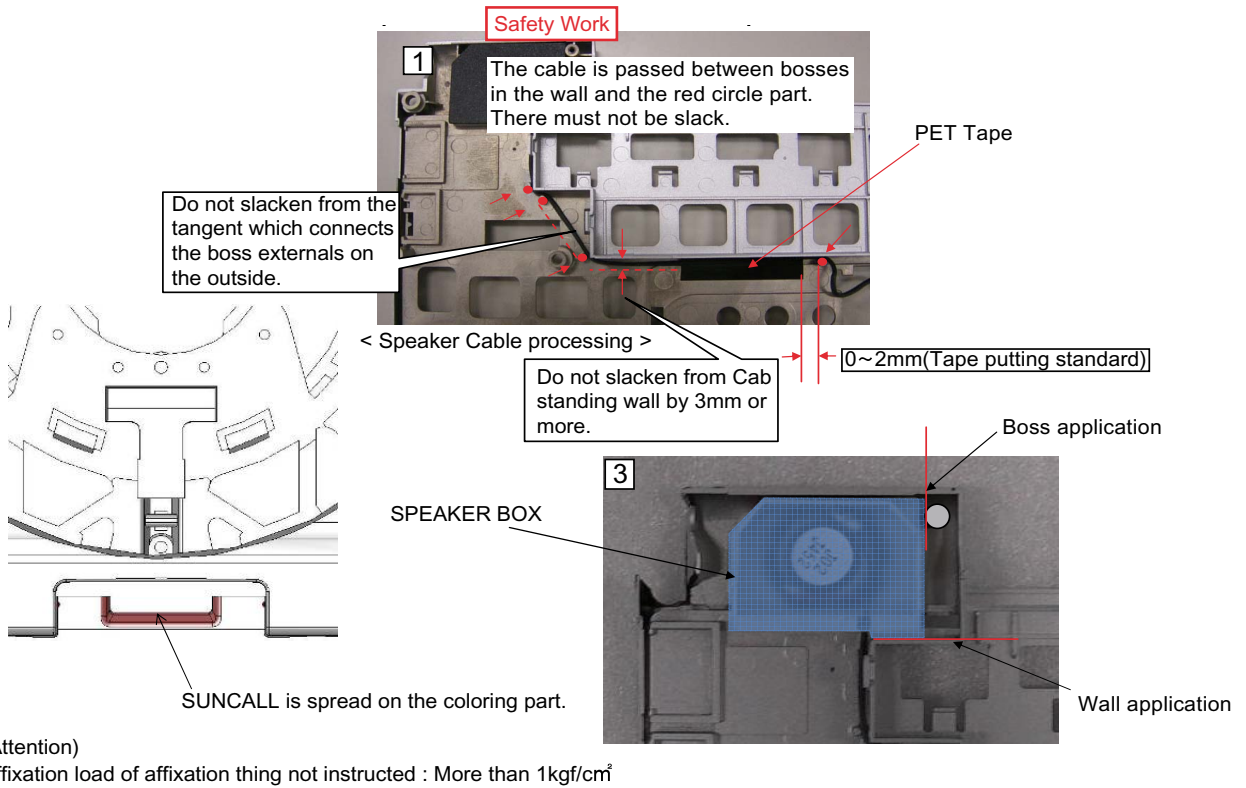

9.3.4.3. Putting HDD Dumper, Hinge Backup Sheet and Spacer Washer etc.

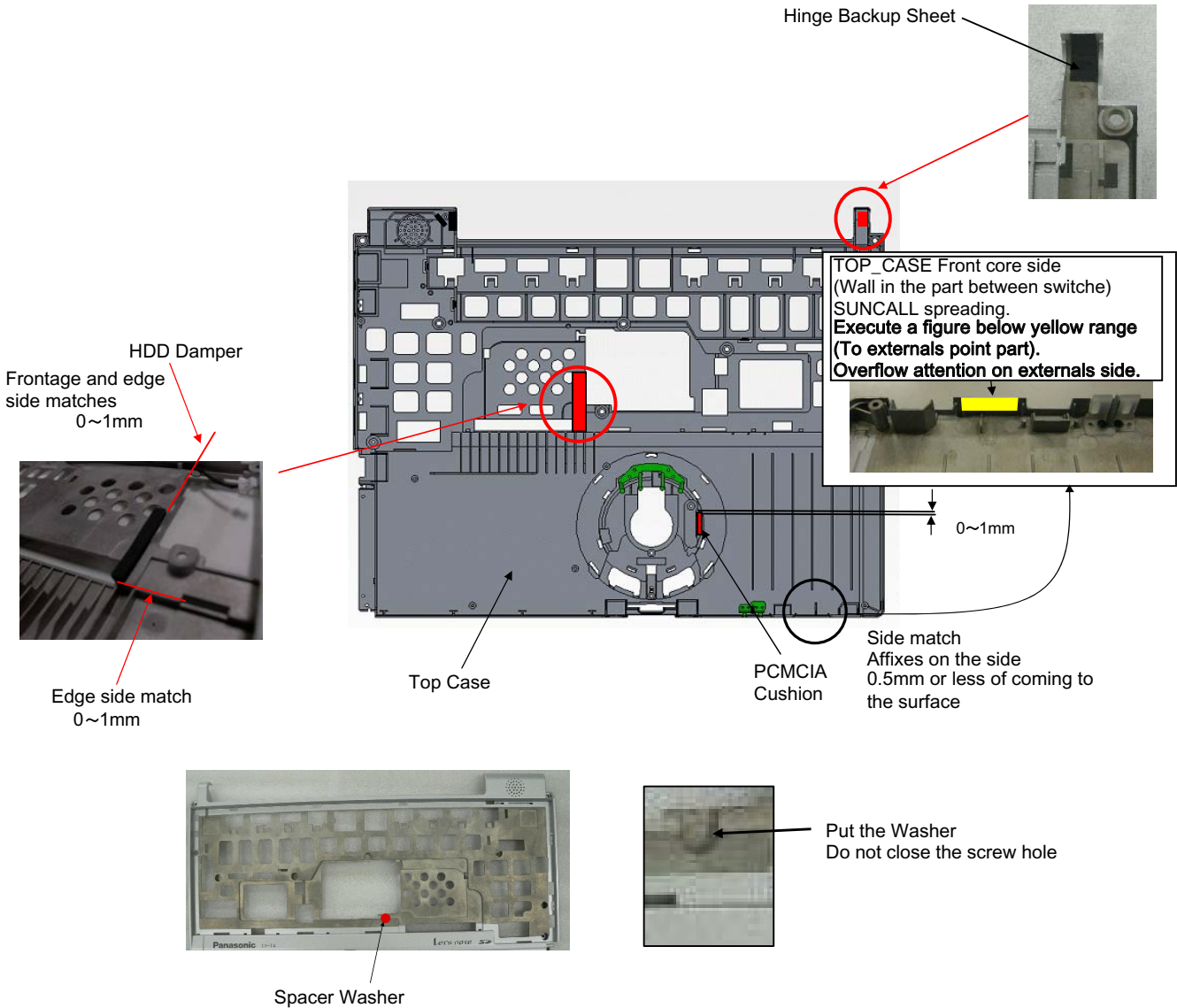

9.3.4.4. Assembly of the LCD Knob

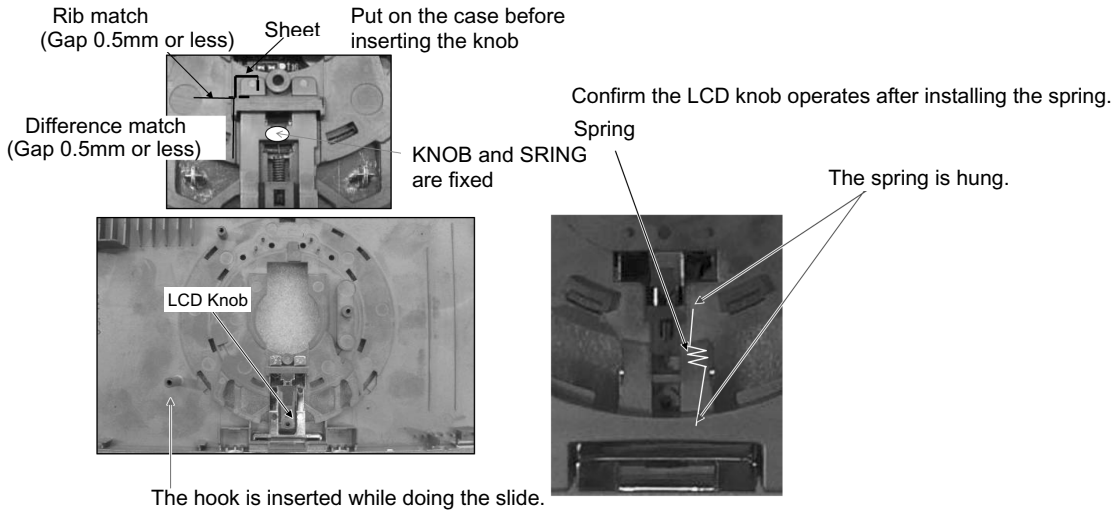

9.3.4.5. Assembly of the Touch Pad

■ Affixation of PAD Cover Tape

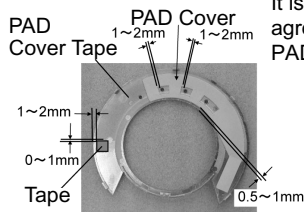

It is a thing which does not run aground in the pin as for the PAD button seat.

The spring installation part opening edge is matched and put between positional decision pins.

■ Insertion of FFC(PAD)

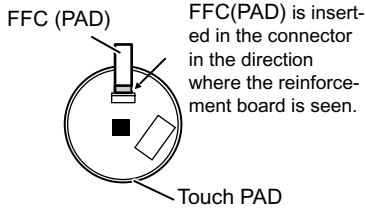

■ Installation of PAD button

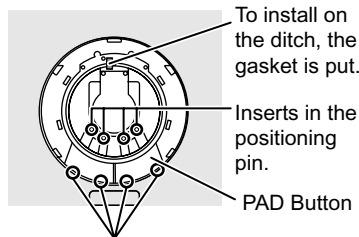

To install on the ditch, the gasket is put.

Inserts in the positioning pin.

■ Affixation of PAD Sheet

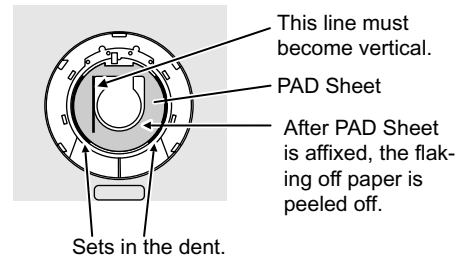

This line must become vertical.

After PAD Sheet is affixed, the flaking off paper is peeled off.

Sets in the dent.

Hook is inserted in a top case.(4 places)

■ Affixation of PAD Sheet

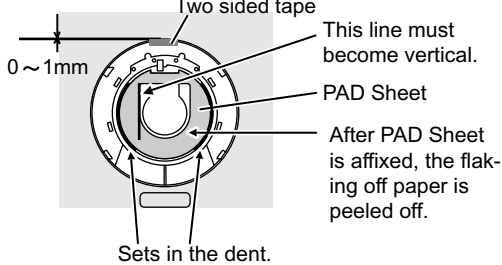

This line must become vertical.

After PAD Sheet is affixed, the flaking off paper is peeled off.

Sets in the dent.

■ Affixation of Touch PAD

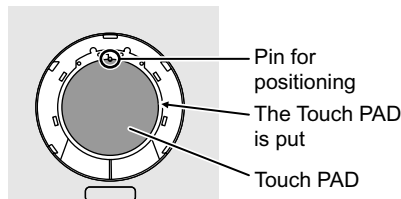

Pin for positioning

The Touch PAD is put

Touch PAD

■ Affixation of PAD Cover

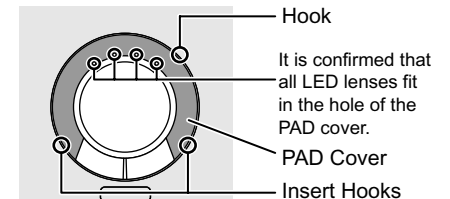

Hook

It is confirmed that all LED lenses fit in the hole of the PAD cover.

Insert Hooks

FFC bend specification

Insert and put a round pin of the lens on U ditch of the cushion.

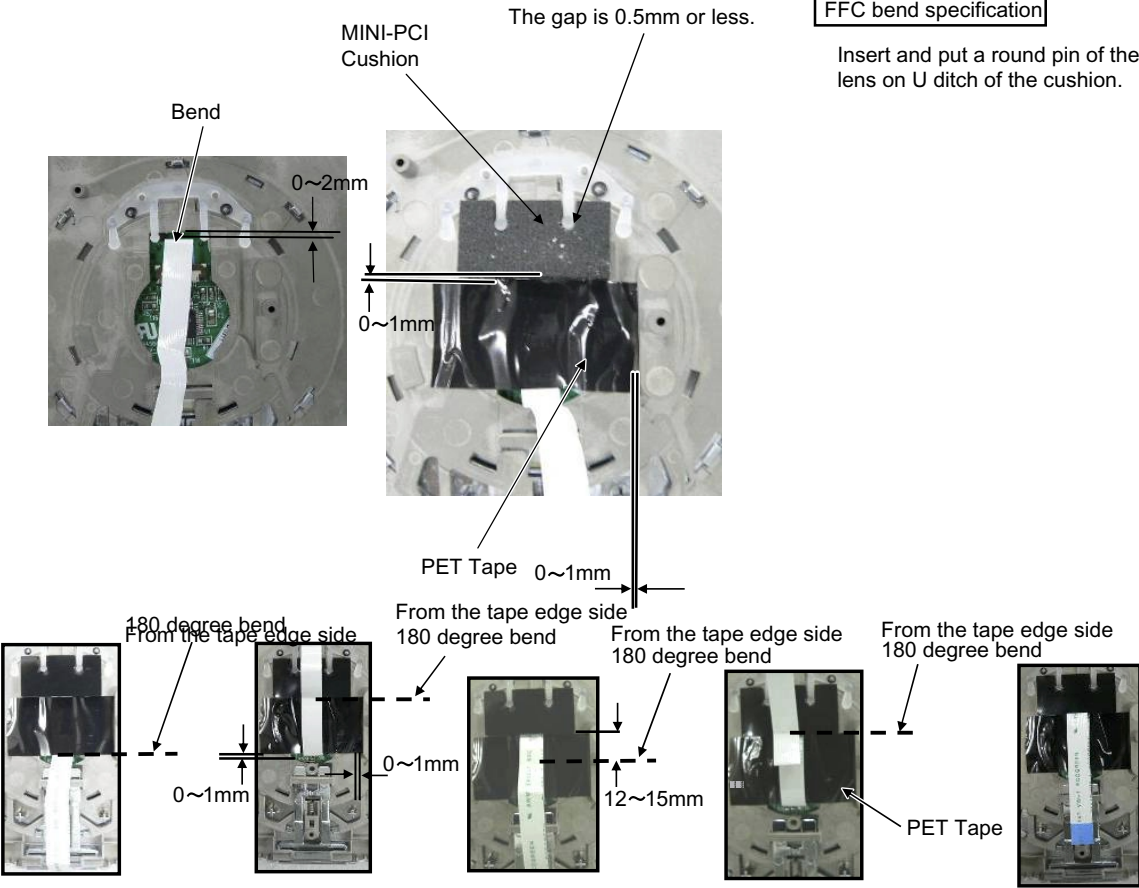

9.3.5. Assembly knowhow of the Bottom Case

9.3.5.1. Setting Antenna Board and Line processing (1)

● Wiring of Antenna Cable (L)

- Process Antenna Cable (L) which remained after installing Antenna Board (L) in the Bottom Case as shown in the figure below.

Safety work

Places between the Bottom Case and installs

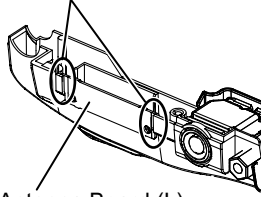

Antenna Board (L)

Safety work

Processes with the boss between ribs

DC-IN is installed in bottom

Safety work

Ferrite sheet is processed in board. The load is not put on the terminal of DC-IN.

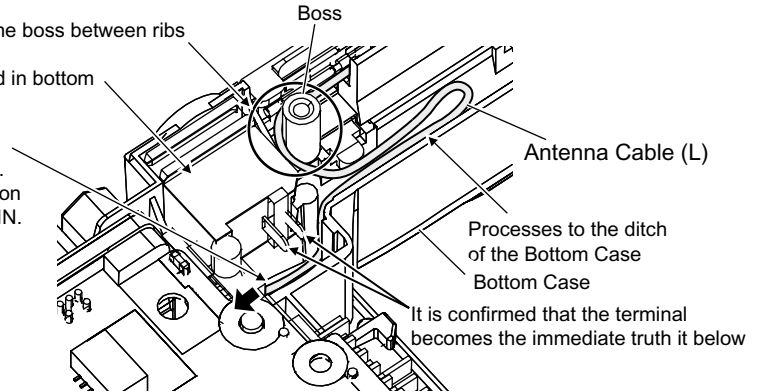

Safety work

- It is confirmed that the terminal becomes straight DC-IN is installed in the Bottom Case

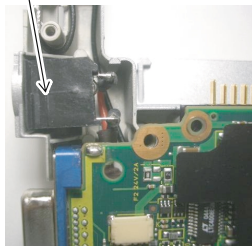

DXQT2+E6FNL

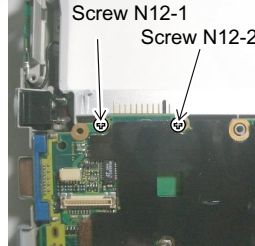

9.3.5.2. Assembly of the Antenna Cover (L)

● Assembly the Antenna Cover (L)

The top side is closed while hooking the hook below on the Bottom Case

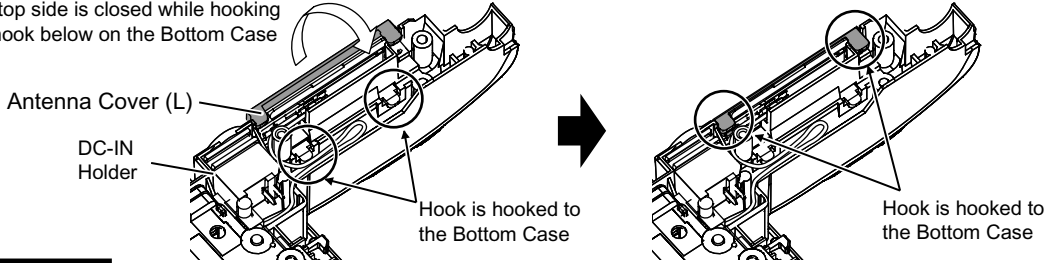

Safety work

- It is confirmed that the terminal becomes straight, installs the DC-IN Holder, and affixation LCD Cable Fix Shee

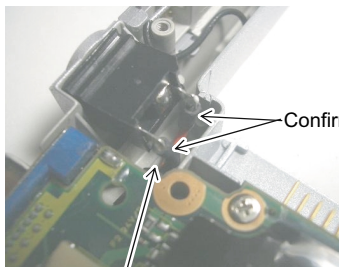

Safety work

- It is confirmed that Ferrite sheet has been inserted under the board.

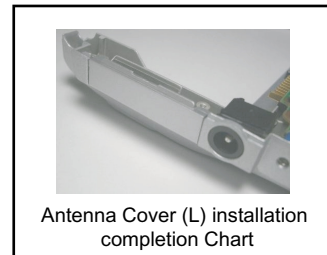
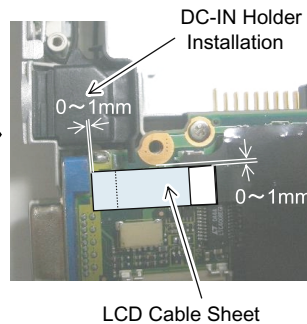

Antenna Cover (L) installation completion Chart

9.3.5.3. Line processing LAN Cable / USB Cable / MODEM Cable

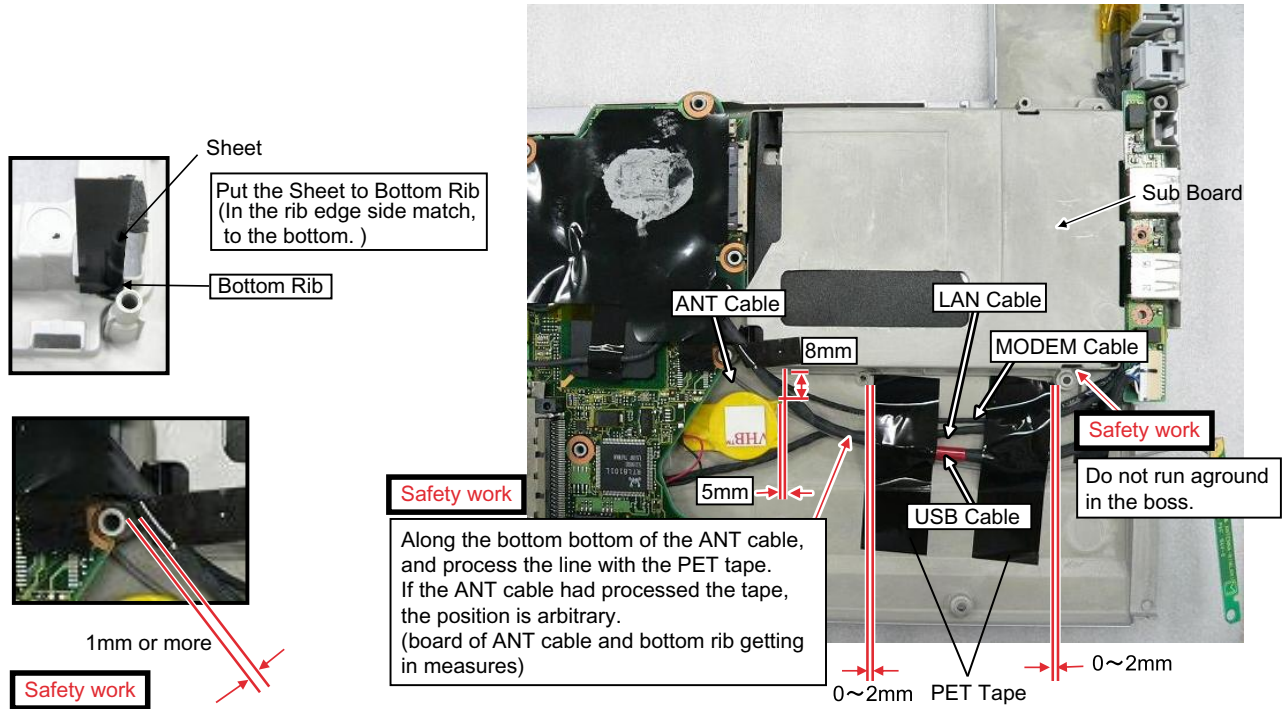

USB Cable and MODEM Cable are fixed to the bottom case with the tape.
 (Do not run aground in the boss. The cable and the boss must be space 1mm or more)

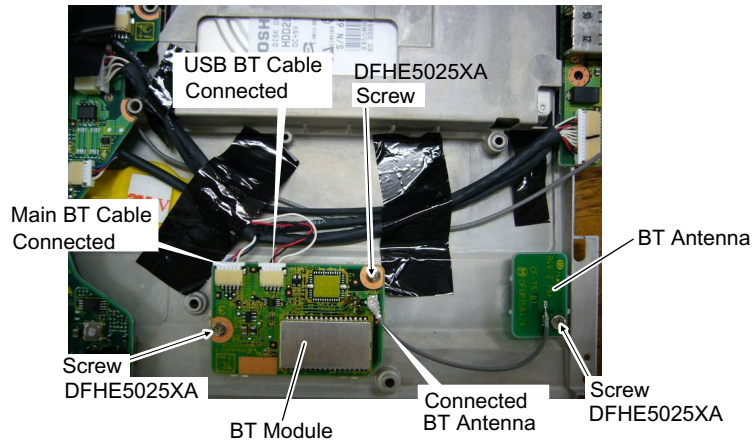

9.3.6. Assembly knowhow of the Body

9.3.6.1. Setting LCD

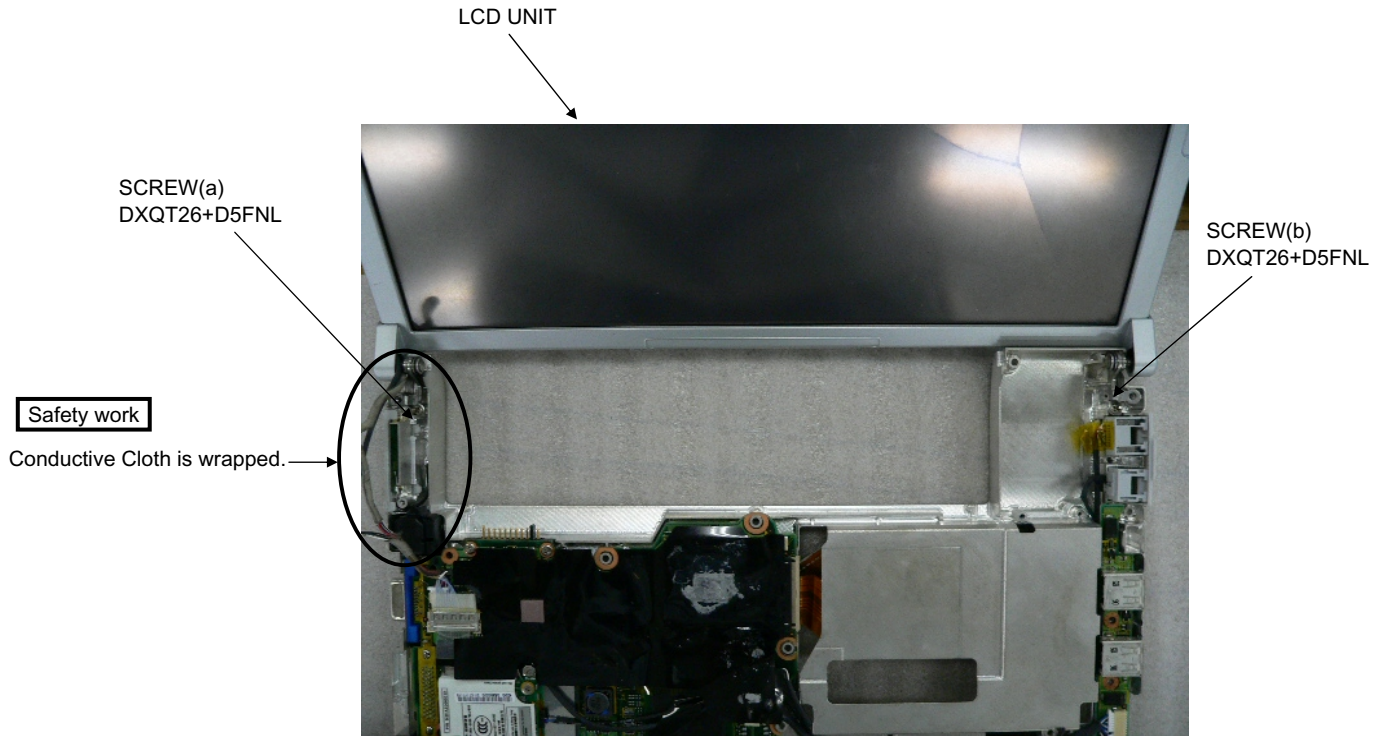

9.3.6.2. Line processing LCD Cable (bottom case side)

※Work is executed in order of (1) (2) (3) (4).

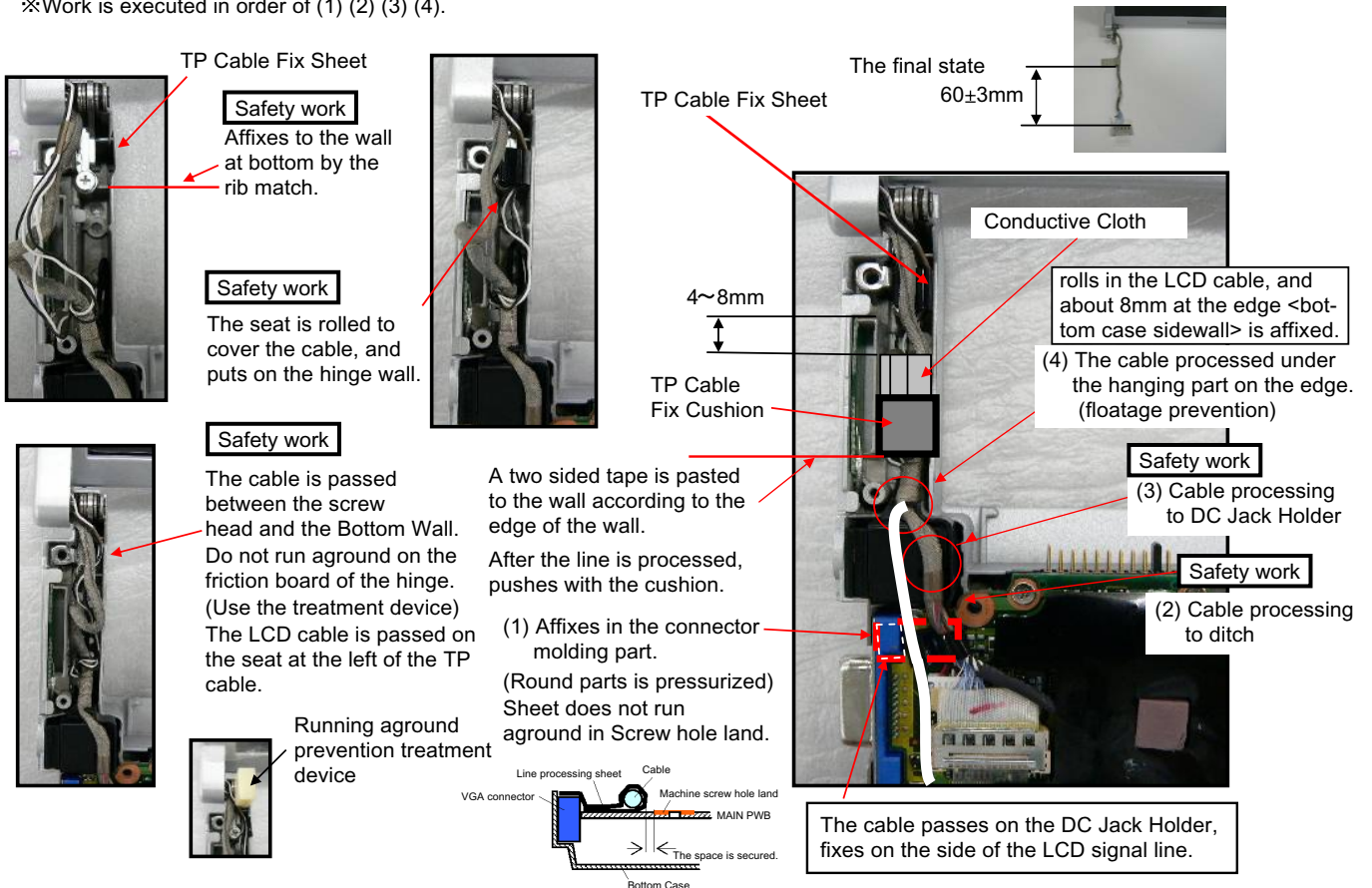

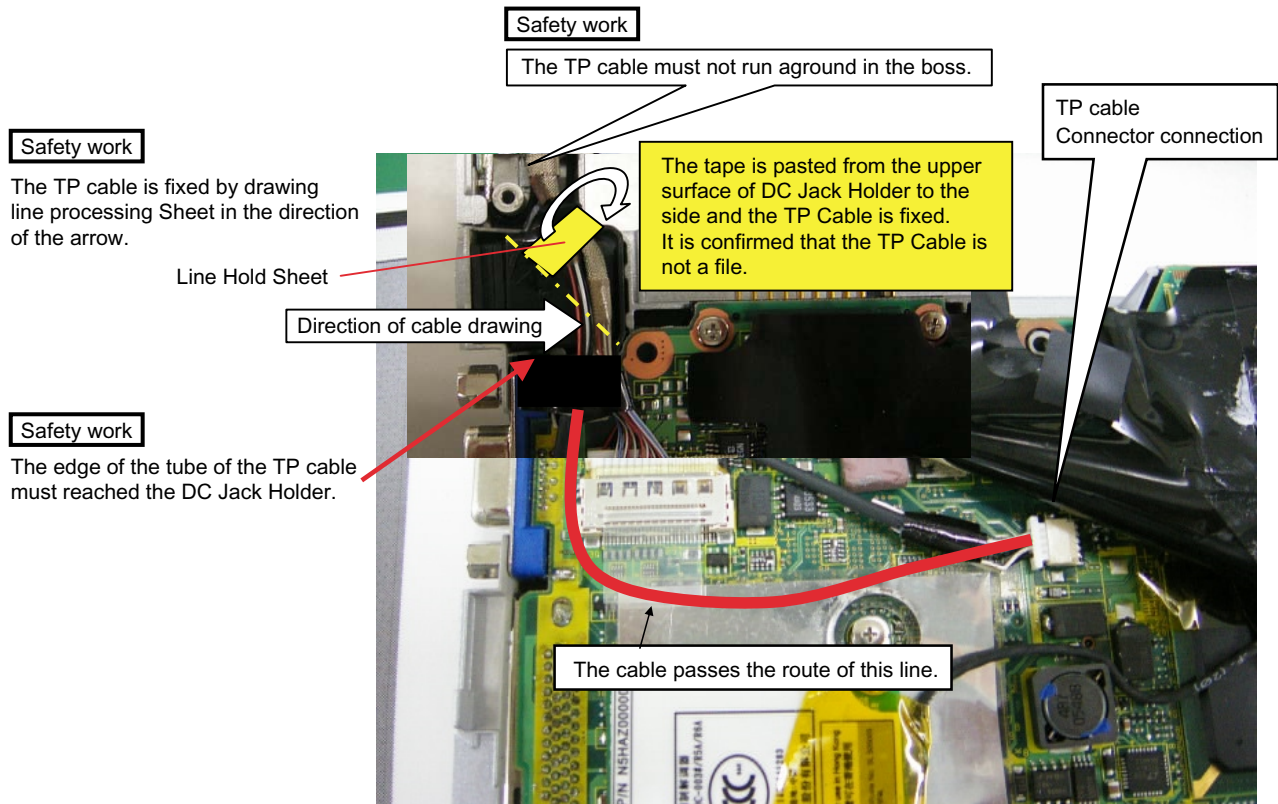

9.3.6.3. Line processing Relay Cable

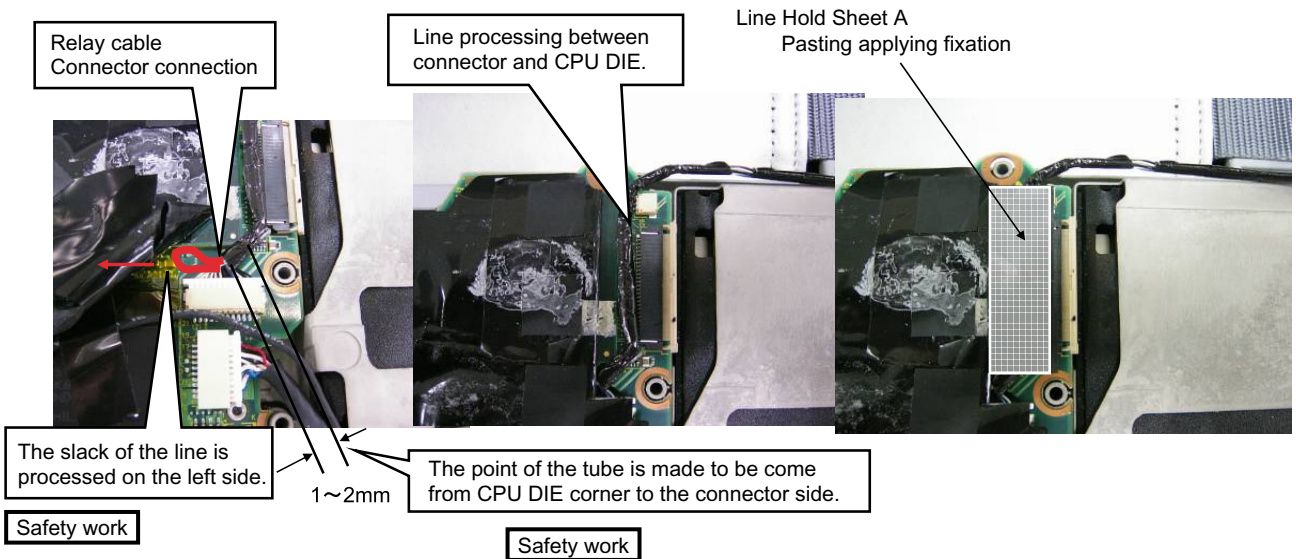

9.3.6.4. Putting Line Hold Sheet WWAN

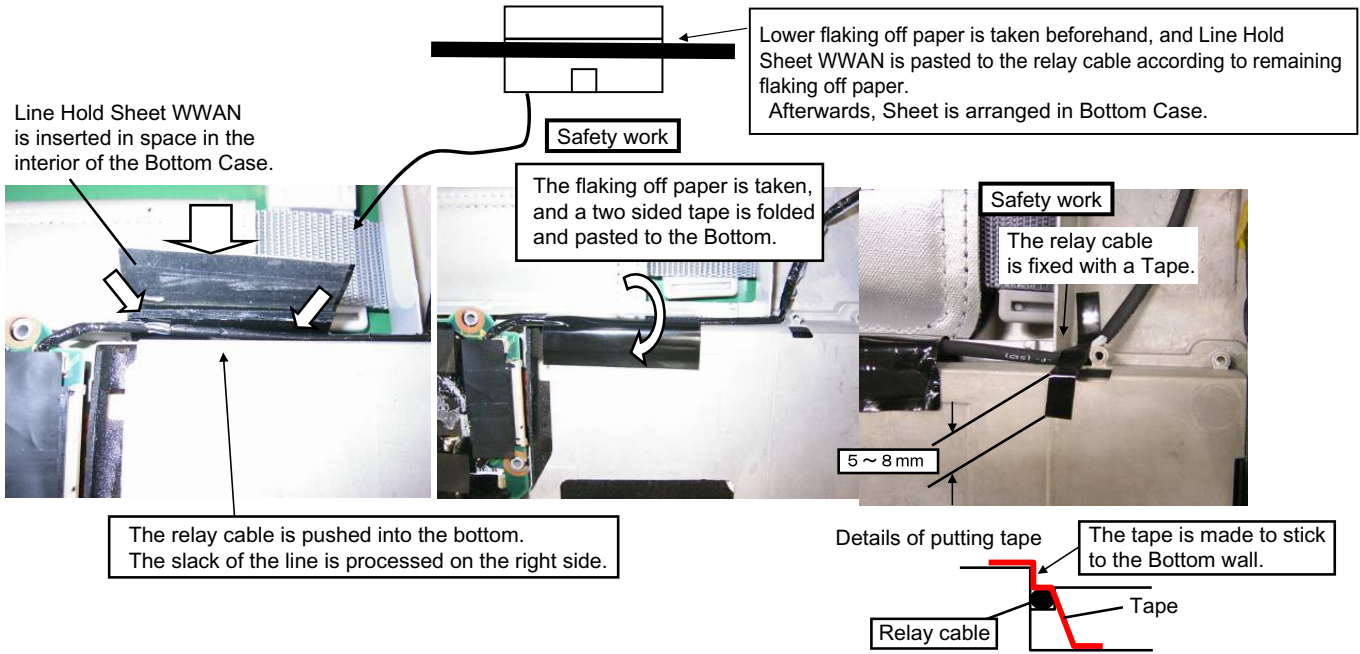

9.3.6.5. Assembly of the Top Case

<The tightening order>

- 1.3 Screws A (DXQT2+E6FNL) are tightened.
- 2.2 Screws B (DXQT26+D8FCL) are tightened.

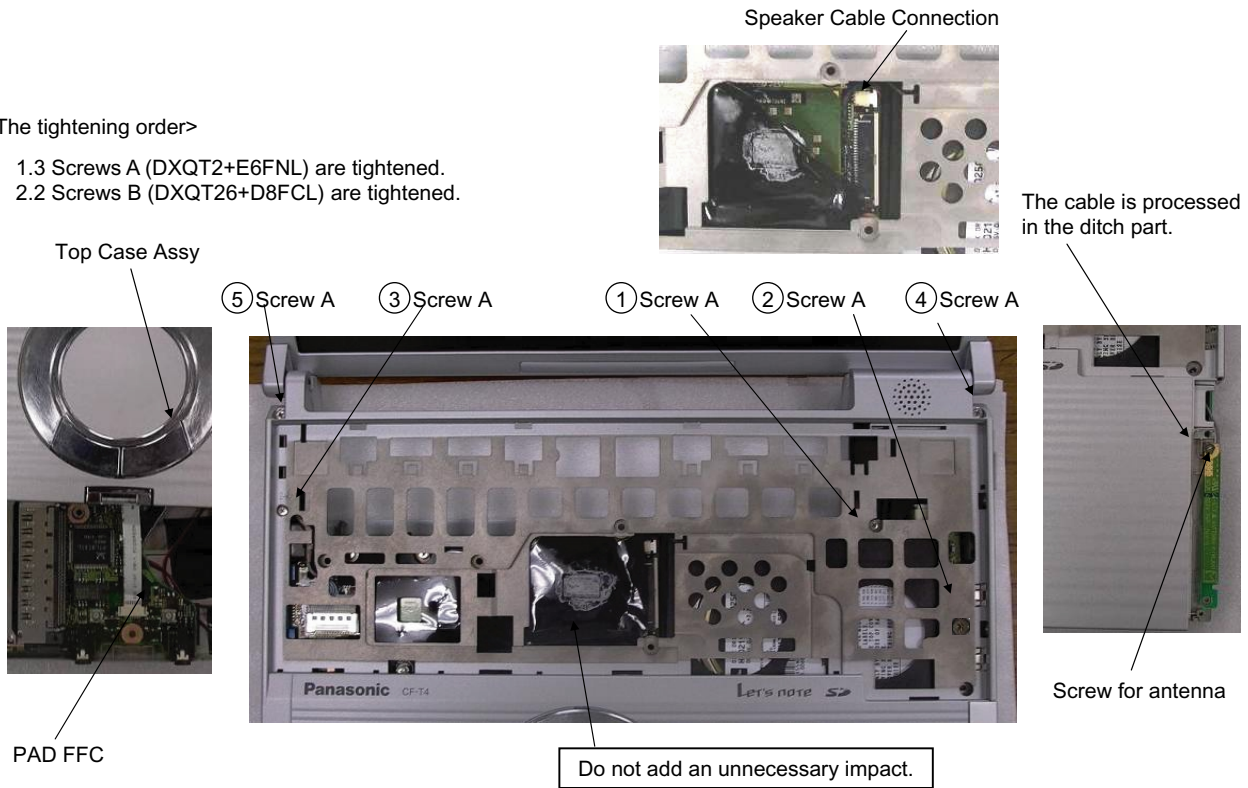

9.3.6.6. Assembly of the Keyboard

● Heat Sheet's KB (largeness) affixation

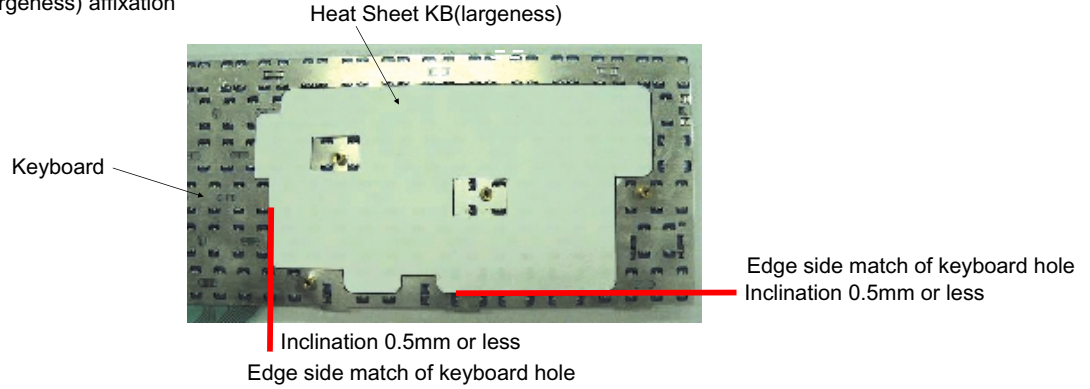

● KB Plate / KB Plate Sheet / Tape affixation

1. KB Plate assembly

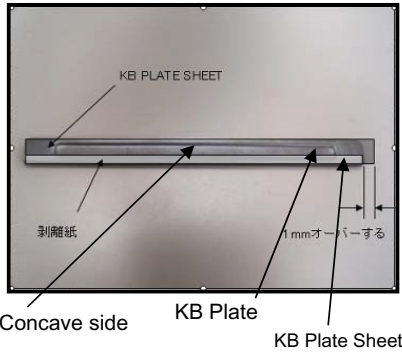

2. Both sides tape affixation

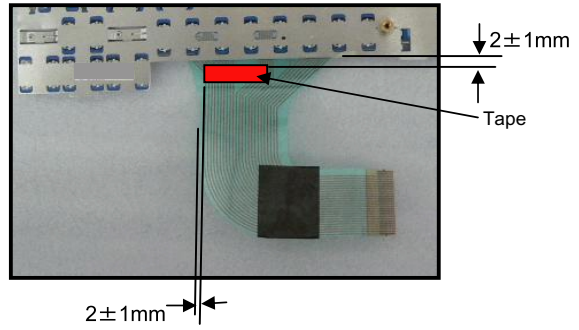

3. Bend of two sided tape putting and KB FPC

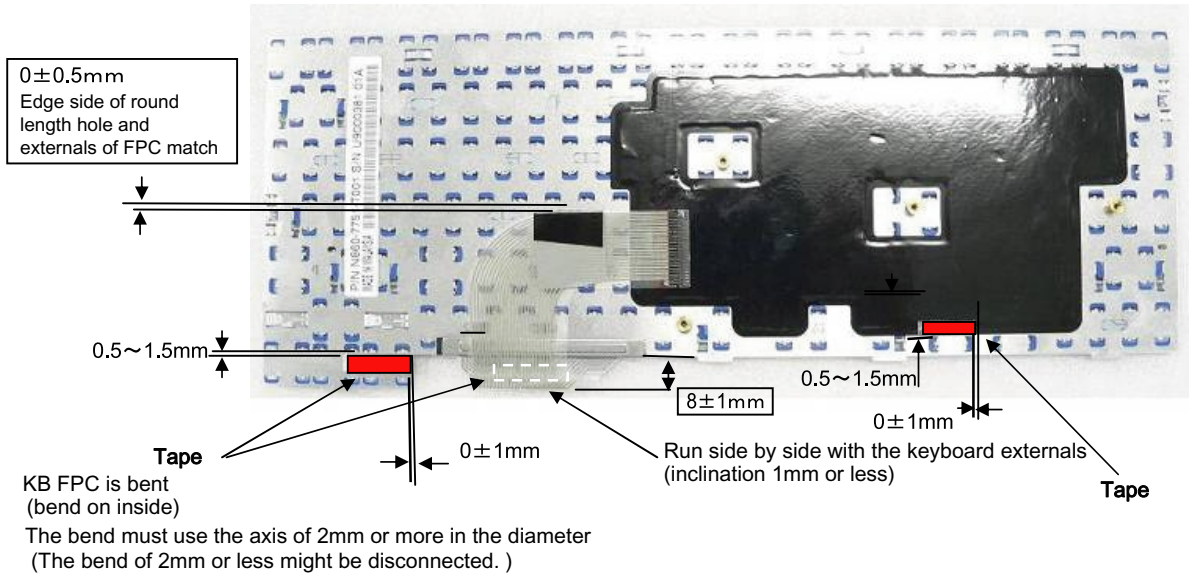

4. Affixation of KB plate

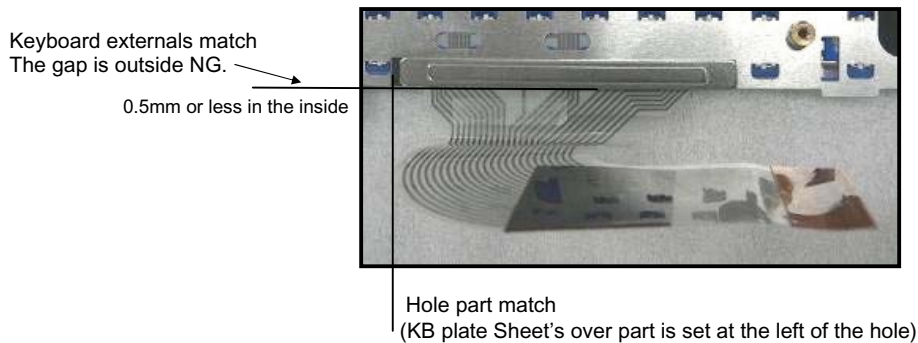

Flake off, and use a two sided tape newly when you recycle the keyboard.

9.3.6.7. Assembly of the Heat Spreader and Side Cover R

Grease (G-751) is spread

1~2mm

A remaining tape is affixed on an opposite side

PET Tape

Heat Spreader(Top Case Side)

1~2mm

Safety work

(Note)
When the part of aluminum with a thin all surroundings bends, Sheet and the cable might be damaged. Therefore, correct when bending. However, correct without correcting by bare-handed with a tool such as pliers.

Heat Spreader(Top Case Side)

Connection

MCH Rubber

Installs in the dent part of a top case
Thing on keyboard installation side without running aground

Side Cover R

2.5~3mm

Inserts from side and raises on

9.3.6.8. Setting Keyboard

Inserts in the corner hole part of a Top Case

Inserts under the Top Case

The hook is Hooked

The hook is Hooked

9.3.6.9. Setting DIMM Cover

Put the DIMM Thermal Sponge

DIMM Cover

Put the DIMM Thermal Sponge

Rib application (Space 0~1mm)

DIMM Cover is arranged making not run aground in screw tightening respect.

Do not run aground on the edge of the DIMM Cover surroundings

For the cutting lack part to get on the boss and so as not to go up, affixation

DIMM Heat Sheet

0~1mm

Insert the RAM module firmly into the inside of the slot.
将内存模块牢牢插入插槽内。

DIMM Cover Sheet

The position where the DIMM Cover and DIMM Heat Sheet is put is this corner line match.
0~1mm

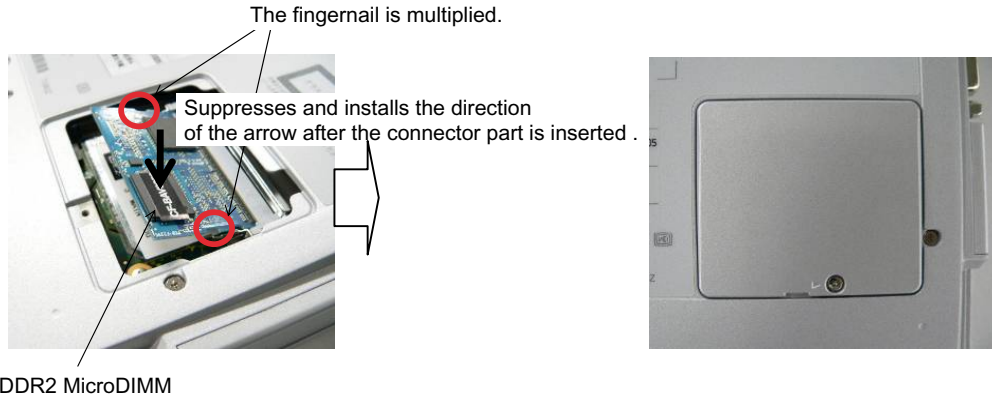

Screw A (XSB2+4FNL) is tightened. DIMM Cover

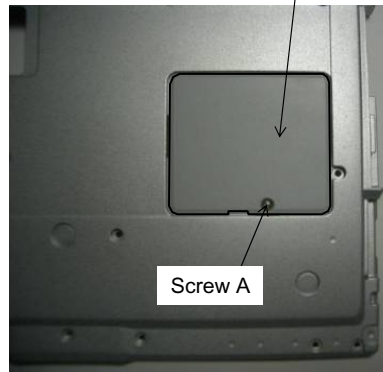

9.3.6.10. The tightening screw of Bottom Case

The Keyboard is inserted and after tightening of the Screw, the Keyboard Hook are inserted in order of the following.

- 1.7 Screws A (DXHM0039ZA) are tightened.
- 2.5 Screws B (DXHM0057ZA) are tightened.
- 3.3 Screws C (DXQT2+E12FNL) are tightened.
- 4.1 Screw D (DXQT2+D4FNL) is tightened.
- 5.1 Screw E (DXQT2+E10FNL) is tightened.
- 6.2 Screws F (DFHE5035ZB) are tightened.
- 7.2 KB Hooks (DFMD4057ZA) are tightened.
- 8.2 Pins (K1YE5000022) are tightened.

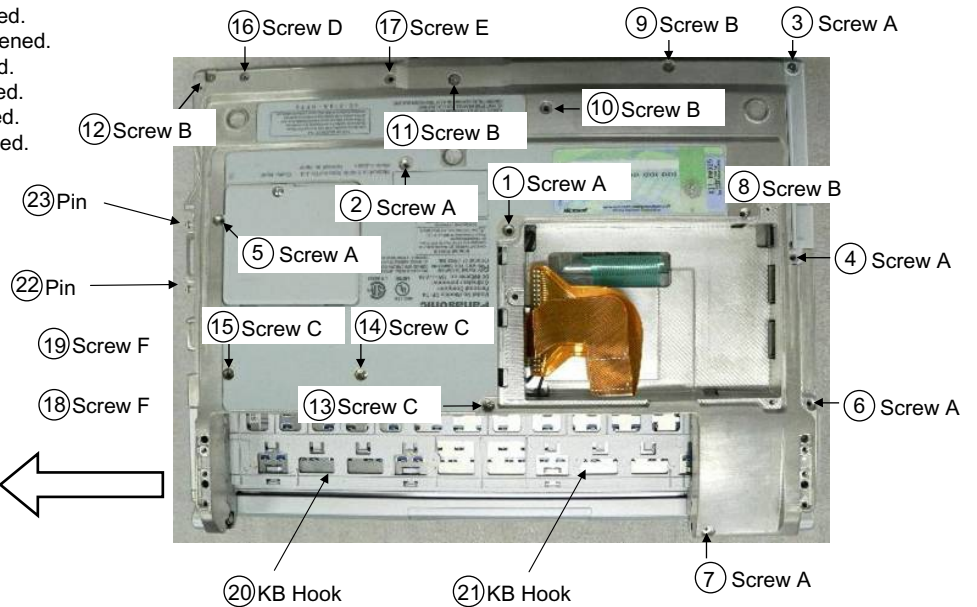
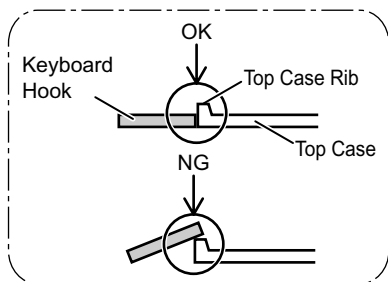

9.3.6.11. Putting Sheets

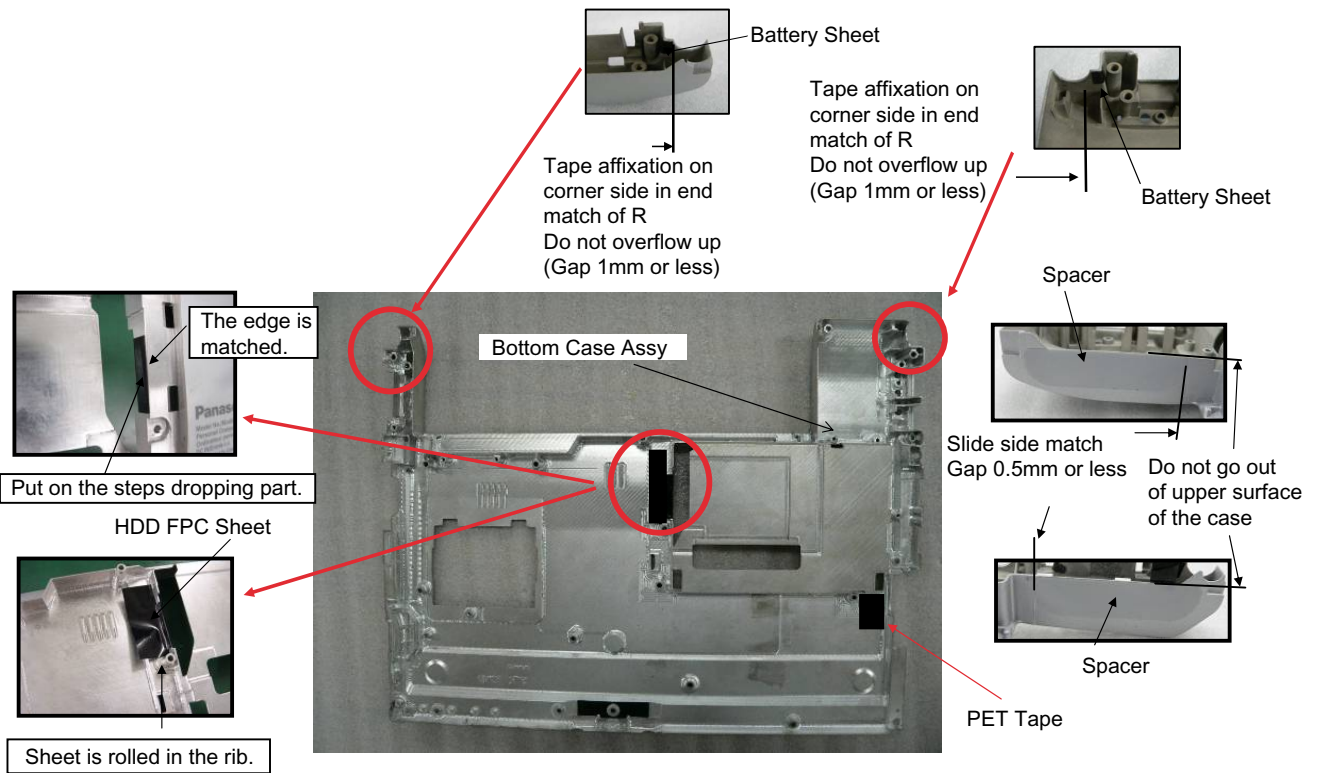
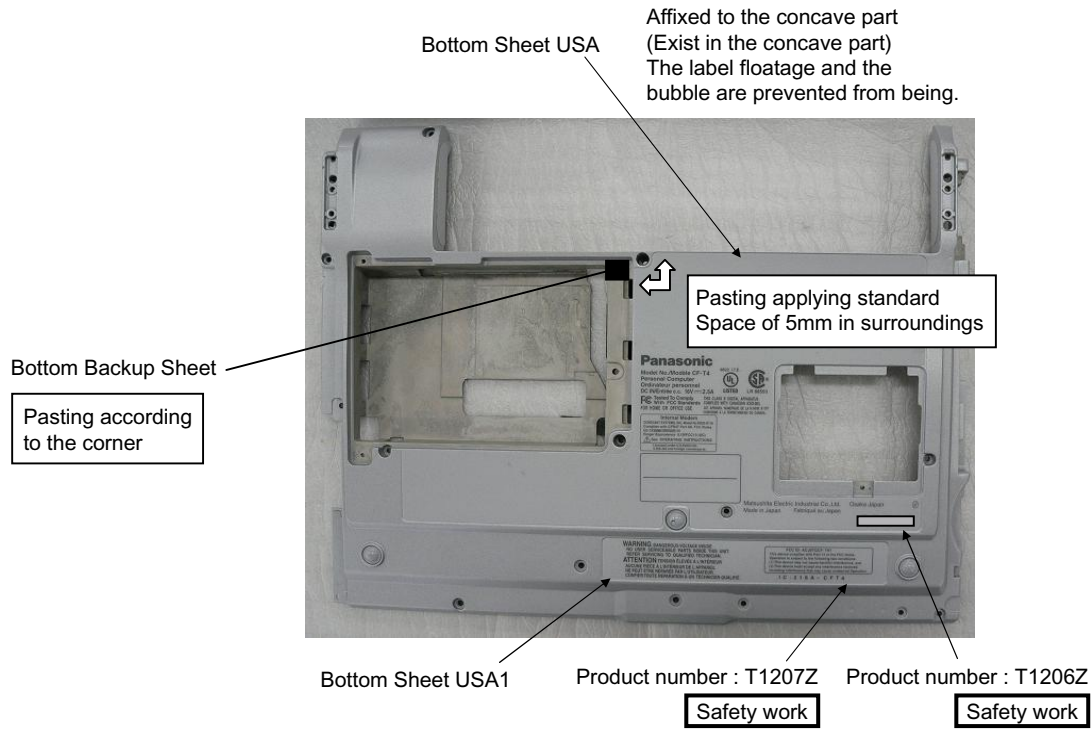

9.3.6.12. Setting Knobs

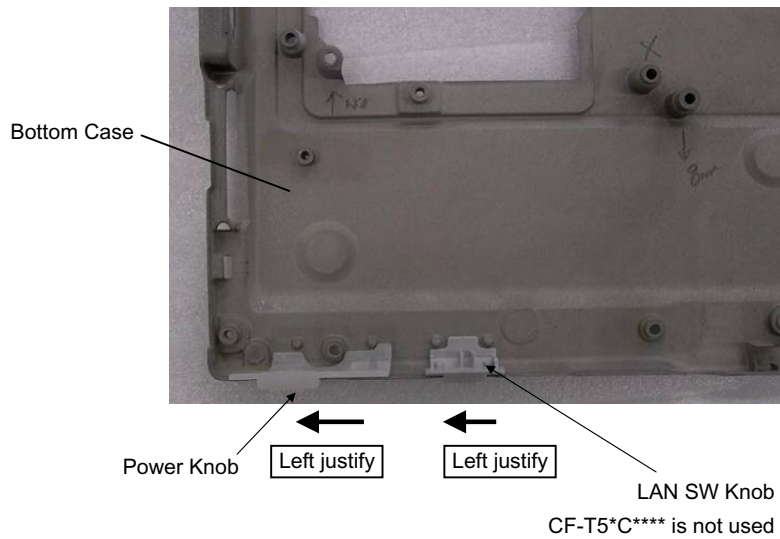

9.3.6.13. Putting RJ Cover and Labels

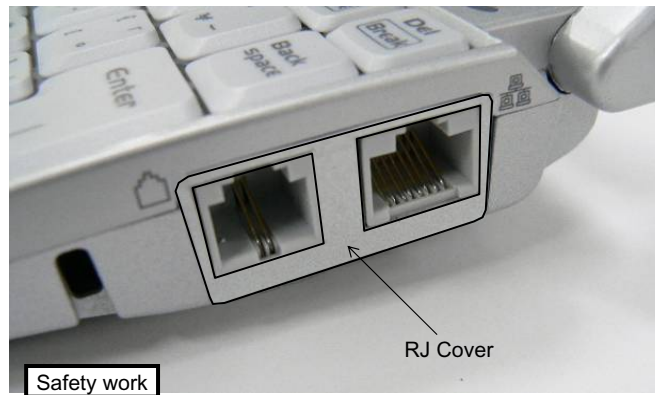

RJ Cover is put on the denting part.
 The paste is prevented from protruding beyond the edge side.
 The cover is prevented from protruding beyond the denting part.
 The cover is prevented from running aground from the denting part.
 It is not possible to recycle.

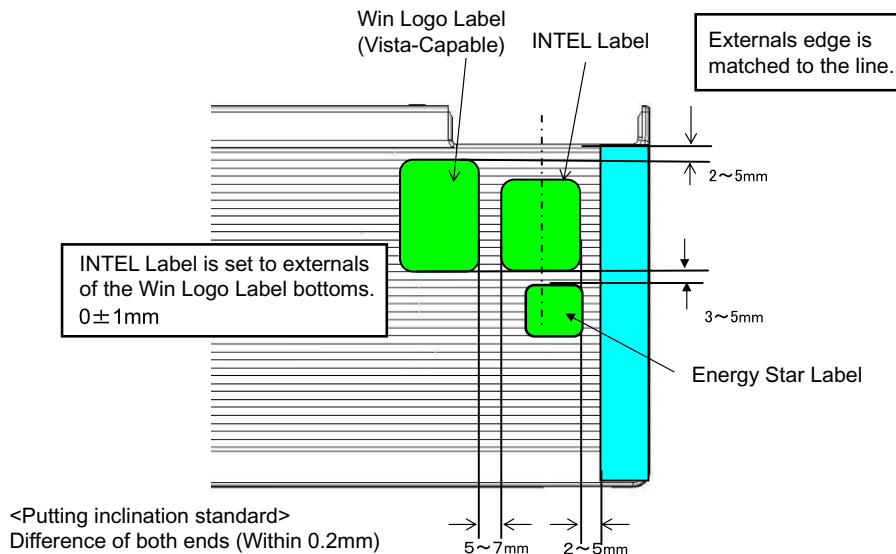

The label paste is prevented from protruding.

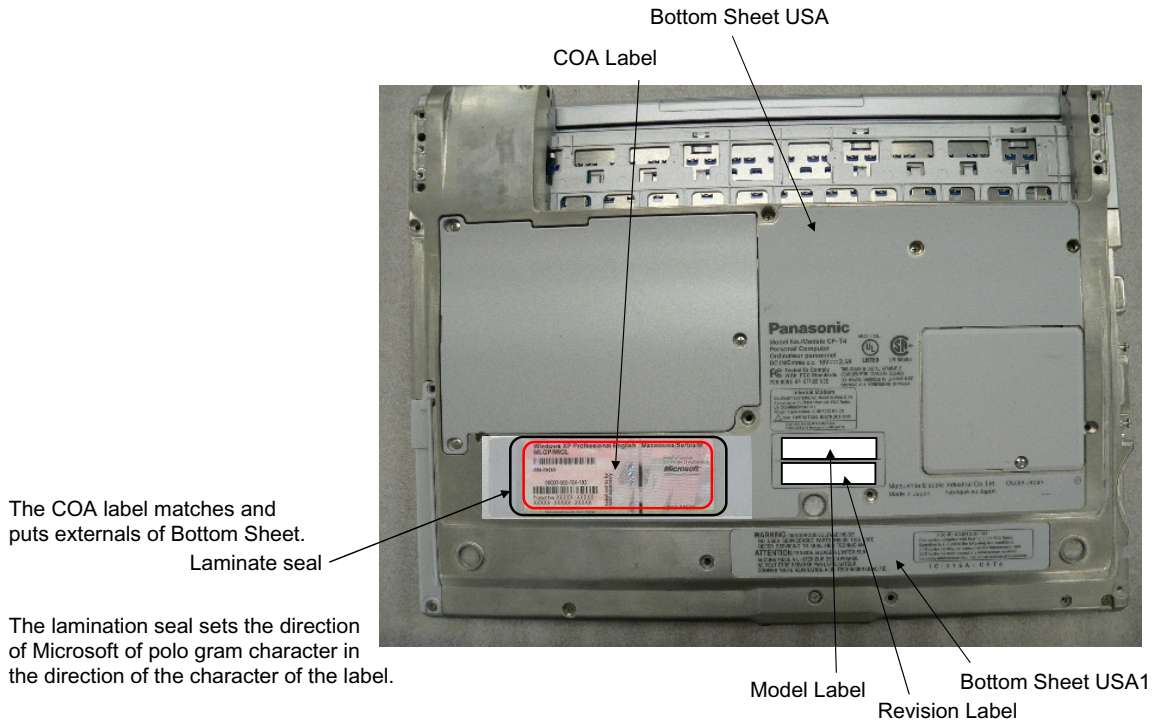

9.3.6.14. Assembly of the HDD / HDD Cover

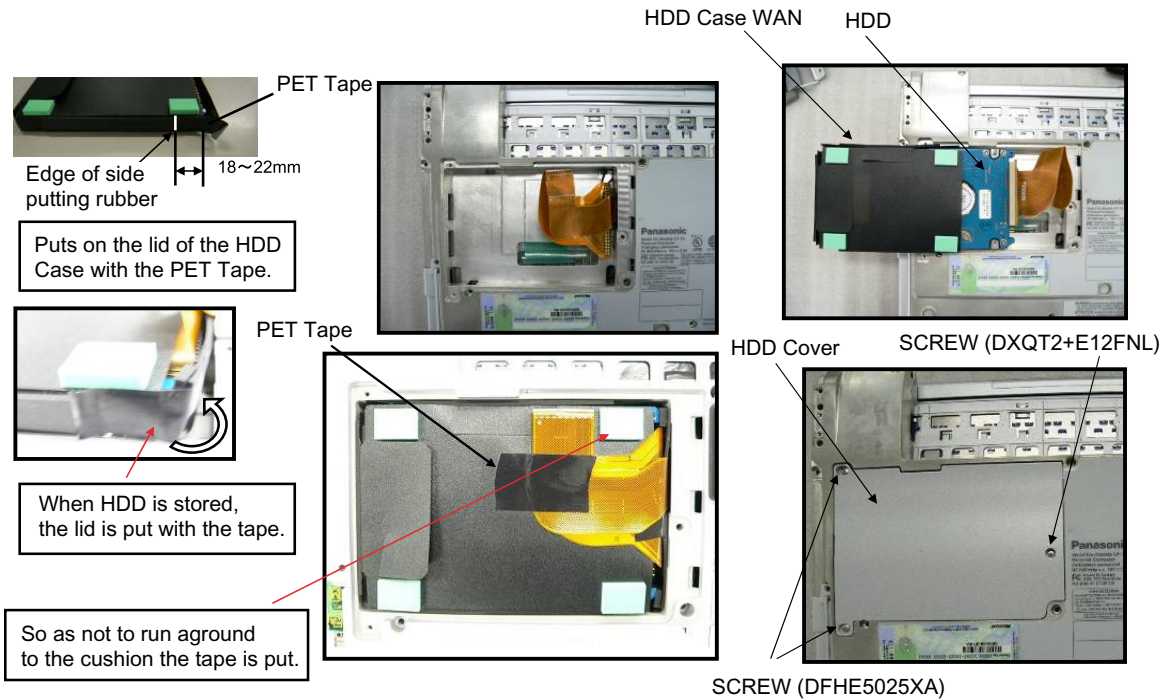

9.3.6.15. Putting HDD Cover Heat Sheet and Bottom Heat Sheet

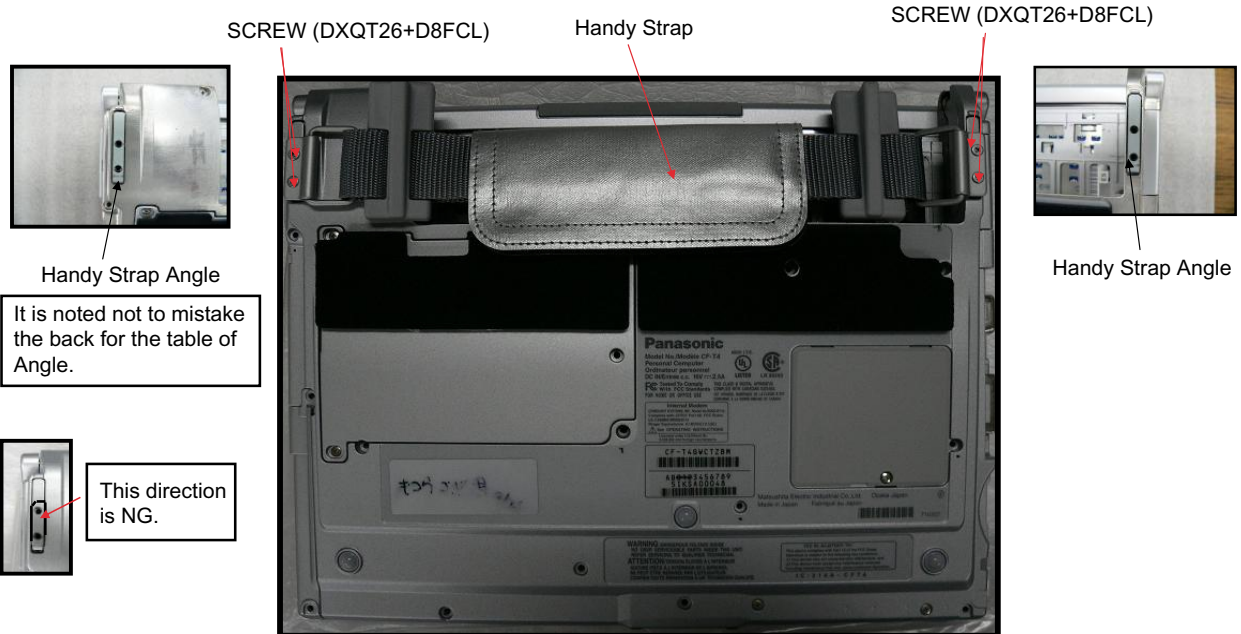
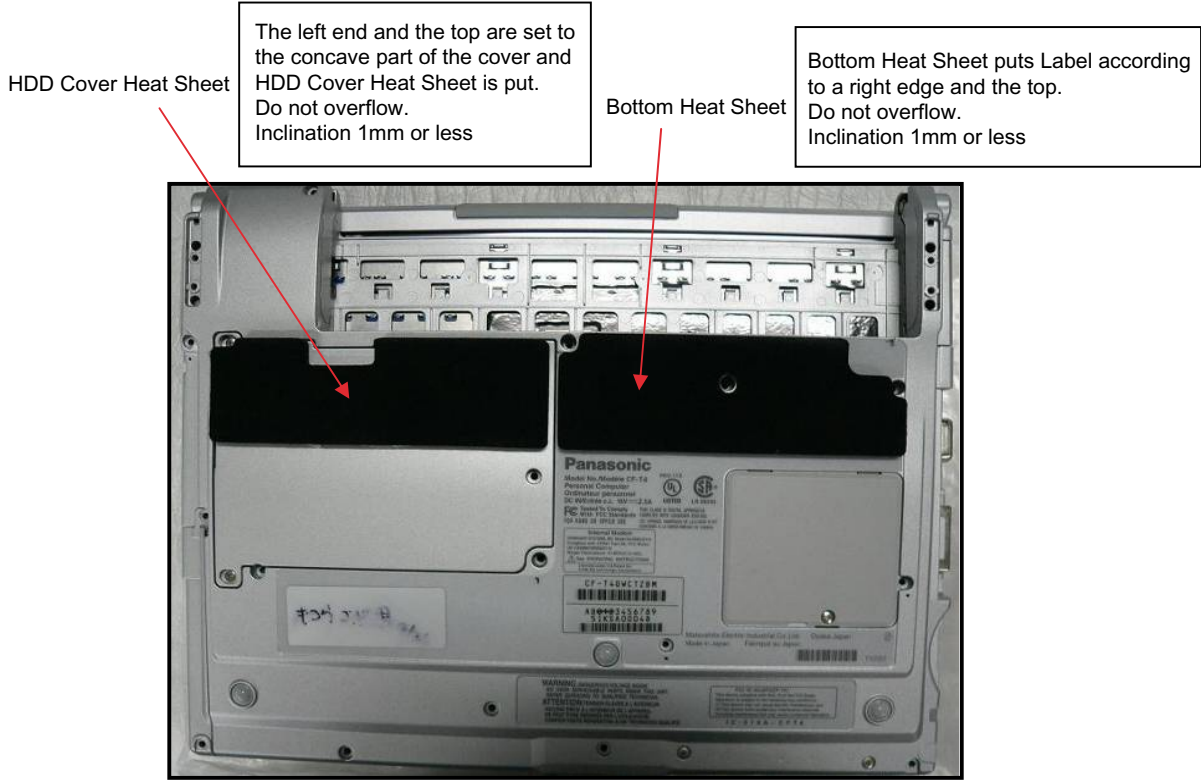

9.3.6.16. Putting Tapes for WWAN Antenna Cable

After the module is tested, the following work is executed.

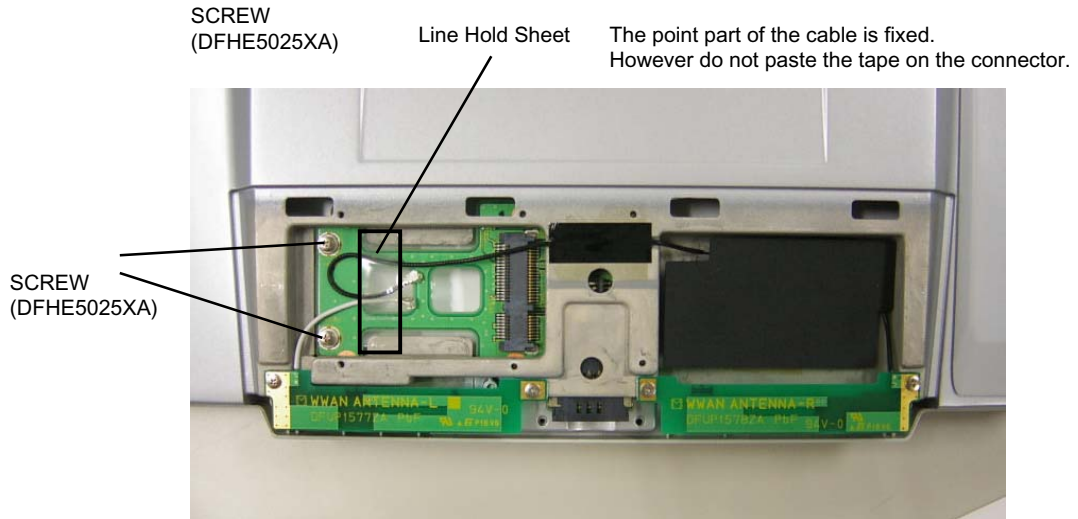

9.3.6.17. Assembly of the LCD Rear

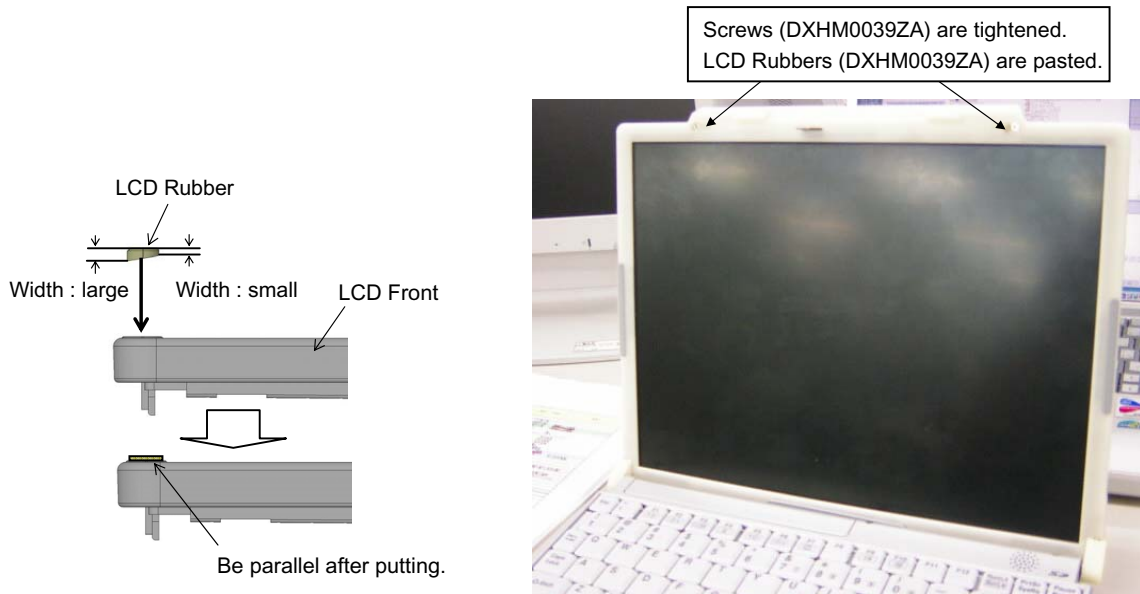
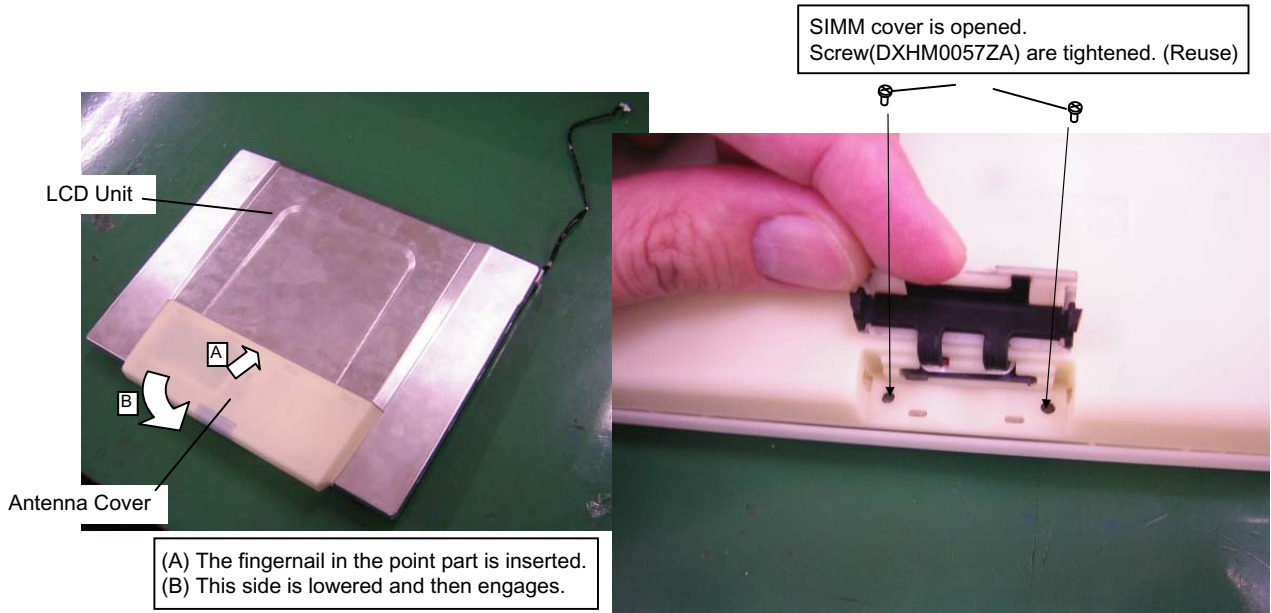

9.3.6.18. Assembly of the WWAN Module

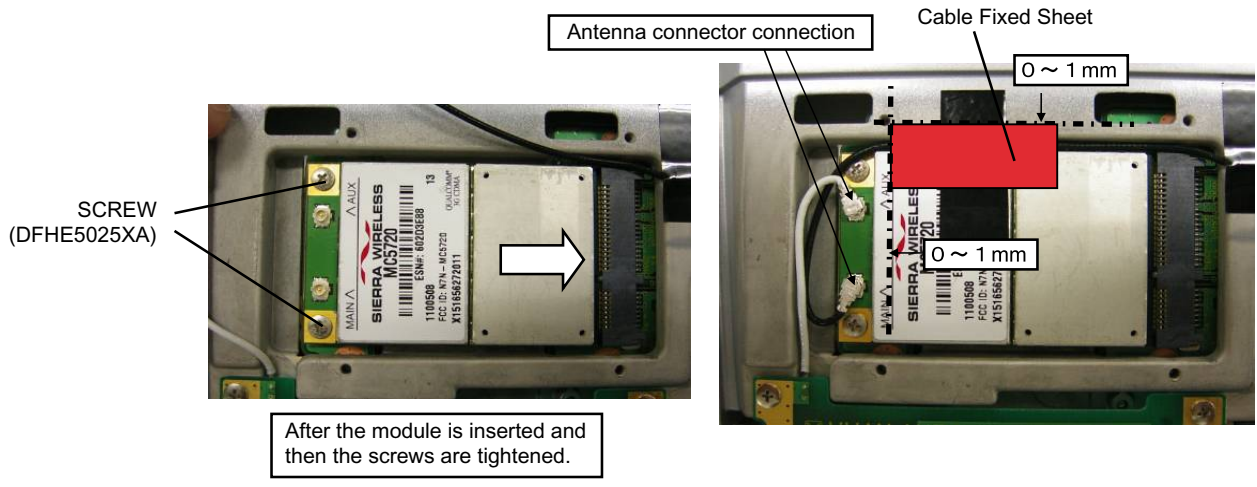
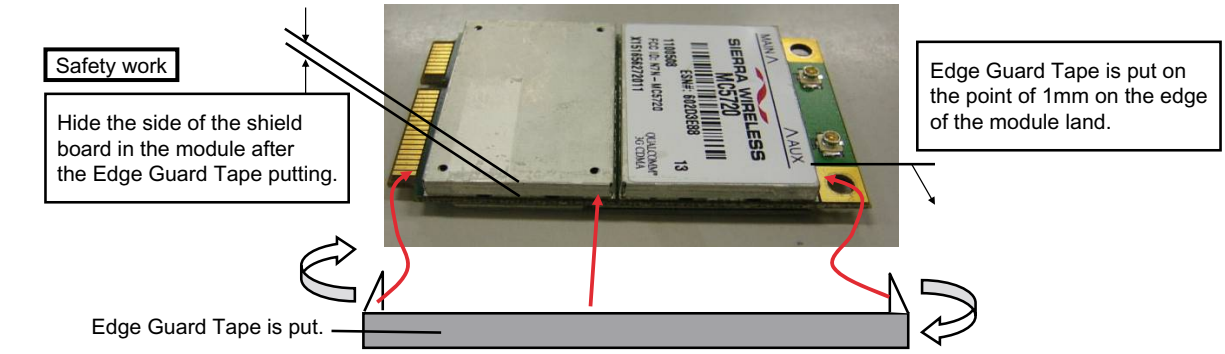

<Notes when module is inserted>

The card shall be inserted and separated correctly according to the direction and the process as shown below.

1. The card shall be inserted or separated with the right parallel to or inclined up to 5° ~ 10° against the mounted board.
2. The card shall be inserted completely.

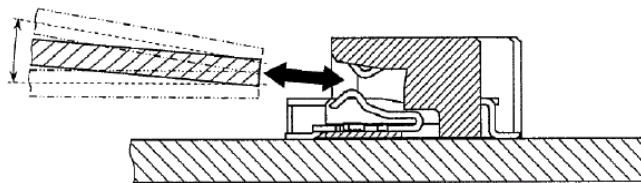

10 Exploded View

10.1. Display Section

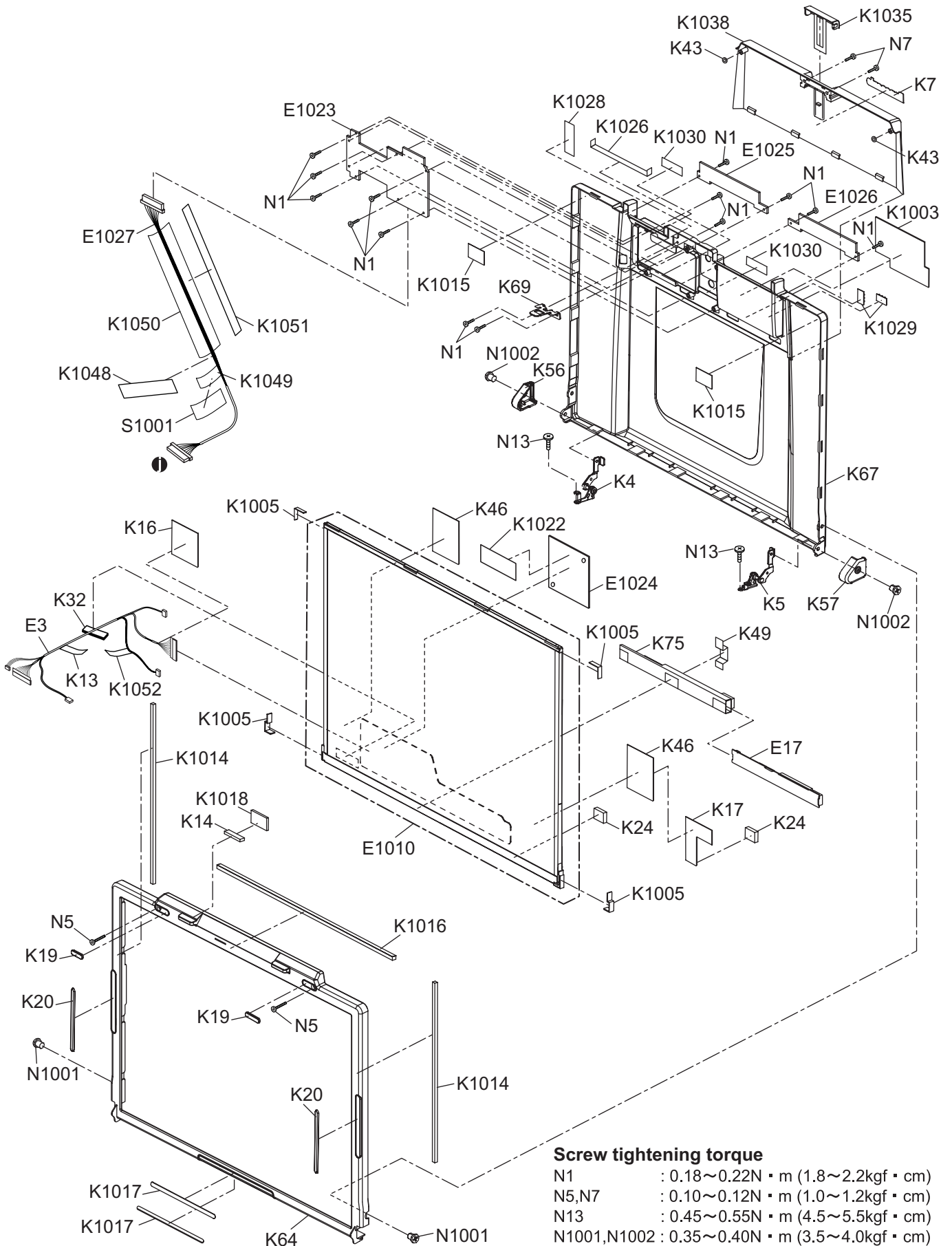

10.2. LCD Unit Ass'y / Pen Holder Section

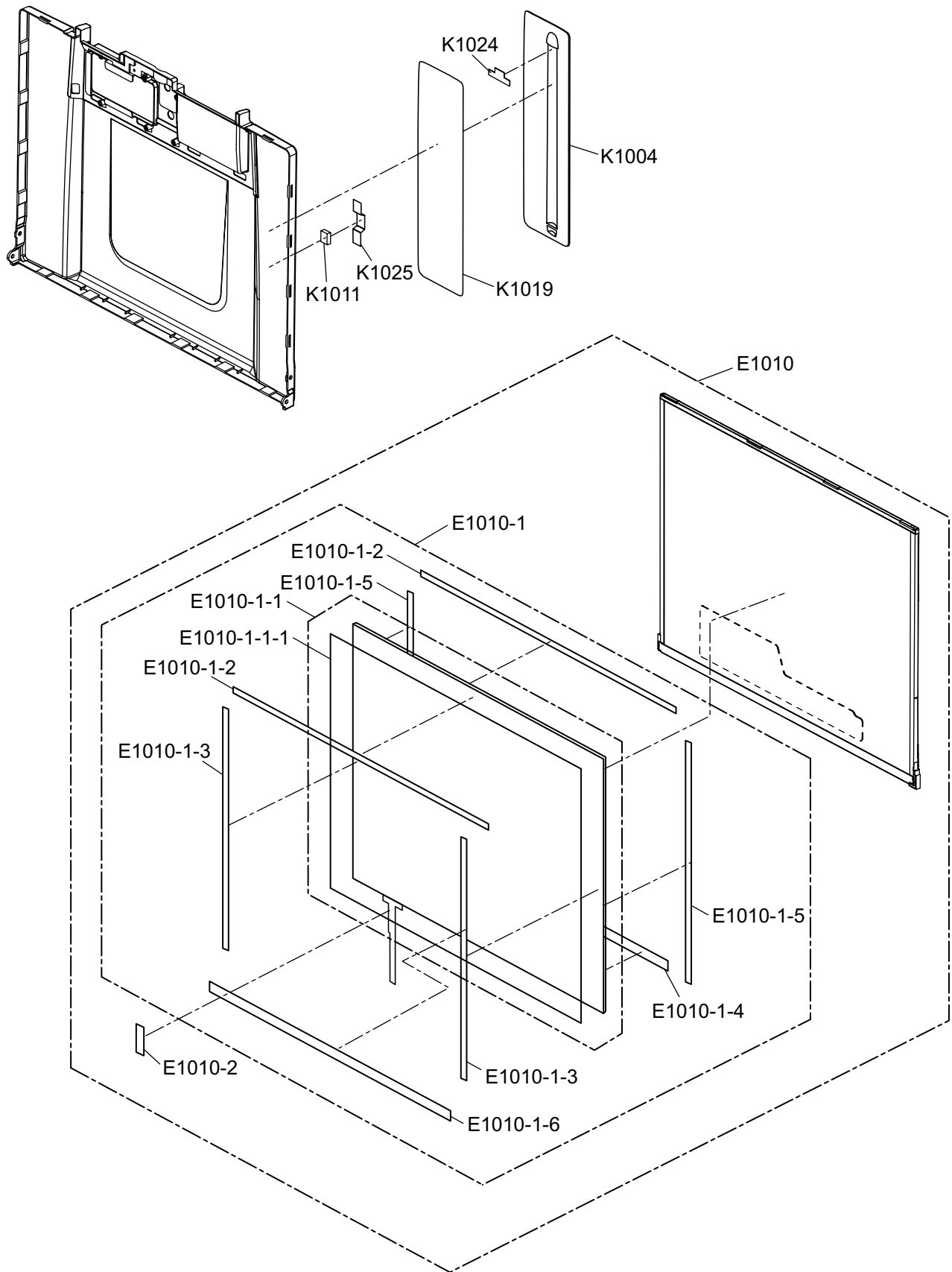

10.3. Cabinet Section

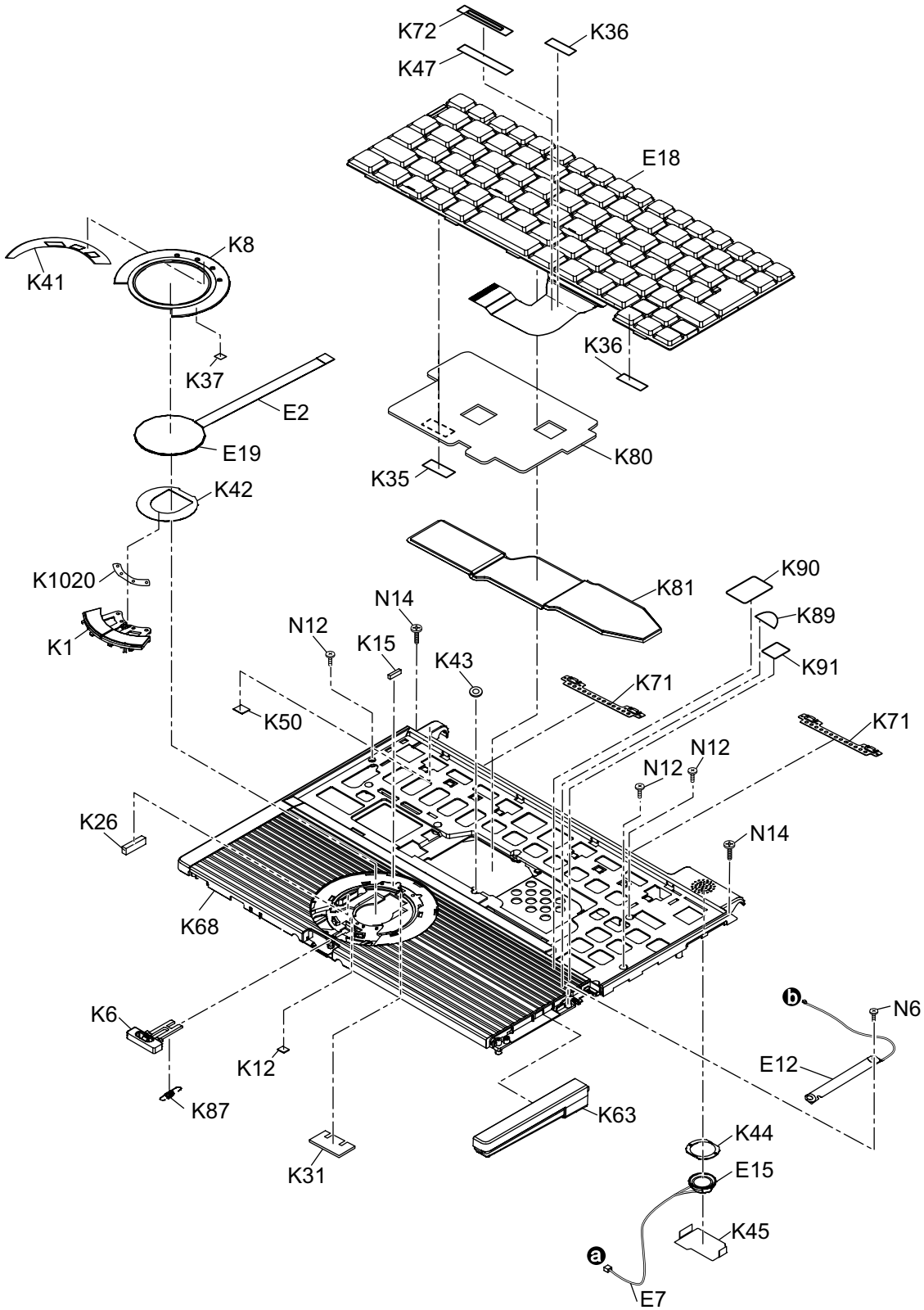

Screw tightening torque

- N6 : 0.10~0.12N · m (1.0~1.2kgf · cm)
- N12 : 0.45~0.55N · m (4.5~5.5kgf · cm)
- N14 : 0.18~0.22N · m (1.8~2.2kgf · cm)

10.4. Bottom Section

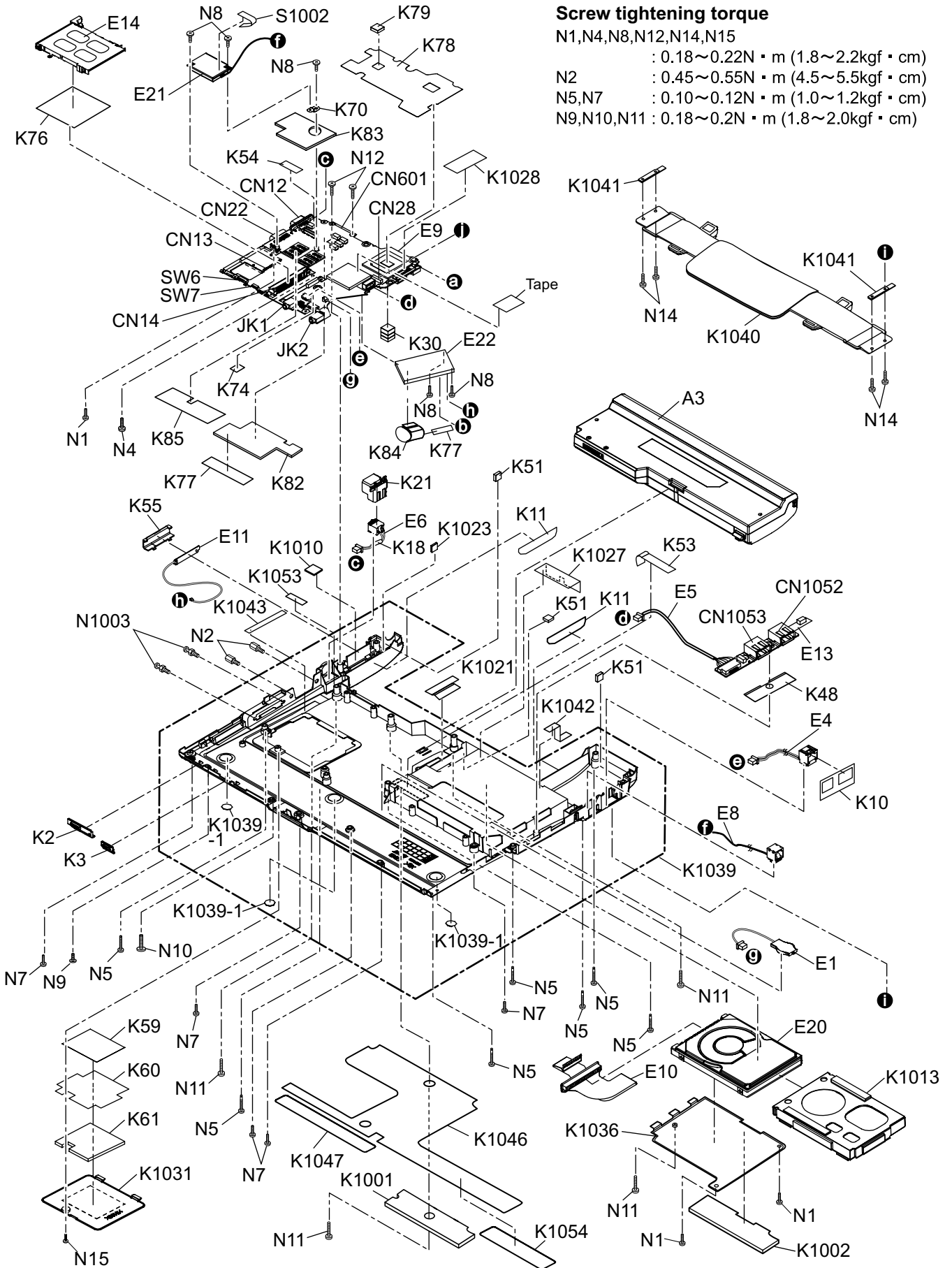

12 Replacement Parts List

Note : Important Safety Notice

Components identified by  mark have special characteristics important for safety. When replacing any of these components, use only manufacturer's specified parts.

CF-T5LWETZBM

REF. NO and AREA	PART NO.	DESCRIPTION	Q'TY
Main Block Unit			
E1	 CR2032/S5Y	LITHIUM BATTERY	1
E2	DFJK12U112BB	PAD FFC	1
E3	DFJS1050ZA	LCD CABLE	1
E4	DFJS958ZB	LAN CABLE	1
E5	DFJS980ZA	MAIN-SUB CABLE	1
E6	 DFJS1020YA	DC-IN CABLE	1
E7	DFJS962ZA	SP CABLE	1
E8	DFJS973ZB	MODEM CABLE	1
E9	DL3UP1534LAA	MAIN PWB UNIT(T5MK1 OVERSEAS)	RTL 1
E10	DL3UP1443AAA	HDD FPC UNIT	1
E11	N1ZY000002	ANTENNA PCB-L ASS'Y	1
E12	N1ZY000003	ANTENNA PCB-R ASS'Y	1
E13	DL3UP1477AAA	2-PORT USB PWB UNIT	1
E14	K1YYZZ000060	CONNECTOR	1
E15	L0AA01A00018	SPEAKER	1
E17	 N0GB1J000012	INVERTOR	1
E18	N2AZZJ000038	KBD US	1
E19	N2EAYYY00008	TOUCH PAD	1
E20	 N3CAYYY00006	HDD (60GB)	1
E21	 N5HAZ000014	MDC MODEM	1
E22	 N5HZC000019	WIRELESS LAN MODULE	1
E1010	DFWV08A0087	LCD UNIT ASS'Y	1
E1010-1	DFWV84A0275	TOUCH SCREEN PANEL KIT	1
E1010-1-1	DFWV84A0267	TOUCH SCREEN ASS'Y	1
E1010-1-1-1	DFHR9063ZA	PROTECTIVE FILM	1
E1010-1-2	DFHG1824ZA	FRONT TP CUSHION A	2
E1010-1-3	DFHG1825YA	FRONT TP CUSHION B	2
E1010-1-4	DFHG1826ZA	FRONT TP CUSHION C	1
E1010-1-5	DFHG1837ZA	FRONT TP CUSHION D	2
E1010-1-6	DFHG1849ZB	FRONT TP CUSHION E	1
E1010-2	DFHR3630ZA	TS FPC SPACER	1
E1023	DL3UP1567LAA	WWAN PWB UNIT	RTL 1
E1024	DL3UP1576LAA	TS PWB UNIT	1
E1025	DL3UP1577LAA	WWAN ANTENNA PCB UNIT(SUB)	RTL 1
E1026	DL3UP1578LAA	WWAN ANTENNA PCB UNIT(MAIN)	RTL 1
E1027	DFJS1048ZA	WM CABLE	1
Accessories			
A1	 CFAA1623AM9	AC ADAPTOR	1
A2	 K2CG3DR00003	AC CORD	1

A3	⚠	CGR-B/979A	LITHIUM ION BATTERY PACK(9CELL)	1
A4	⚠	DFQX5616ZA	MANUAL(CF-T5MK1)	1
A5		DFHR9081XA	PEN	1
A6		DFME0148ZA	TETHER T4	1
A7		DFJS1070ZA	MODEM CABLE	1
A8		DFHS9017ZA	TOUCHPANEL FUKINUNO	1
Packing Material				
P5		DFPK1194YA	PACKING CASE(OVERSEAS)	1
P6		DFPN0833ZA	CUSHION B	2
P7		DFPN0846ZA	CUSHION T	2
Mechanical Parts				
K1		DFBC0321ZA-0	PAD BUTTON	1
K2		DFBD0180ZB-0	POWER SWITCH KNOB	1
K3		DFBD0182ZA-0	LAN SWITCH KNOB	1
K4		DFBH3041ZA	HINGE-L TP	1
K5		DFBH3042ZA	HINGE-R TP	1
K6		DFBS0076ZA-0	LCD KNOB T5 WAN1	1
K7		DFGB0089VB-0	PANASONIC LABEL	1
K8		DFGE0124ZB-0	PAD COVER	1
K10		DFGX0425ZA-0	RJ COVER	1
K11		DFGX0428ZA-0	BATT SHEET(T4)	2
K12		DFHE0215ZA	SHEET	1
K13		DFHE0436ZA	CLOTH LCD CABLE 1	1
K14		DFHE0843ZA	LCD MAGNET	1
K15		DFHE0844ZA	GASKET PAD	1
K16		DFHE0943ZA	GASKET CLOTH(LCD CABLE)	1
K17		DFHE0945ZA	GASKET CLOTH(LCD)	1
K18		DFHE0953ZA	FERRITE SHEET	1
K19		DFHG1546ZB-0	LCD RUBBER	2
K20		DFHG1766ZA-0	LCD SIDE RUBBER	2
K21		DFHG1767ZA-0	DC JACK HOLDER	1
K24		DFHG1773ZA	LCD DAMPER C	2
K26		DFHG1778ZA	PCMCIA STOPPER CUSHION	1
K30		DFHG1786ZA	CPU CUSHION	1
K31		DFHG1787ZA	MINI-PCI CUSHION	1
K32		DFHG1797ZA	REAR DAMPER	1
K35		DFHP7098ZA	KB TAPE	1
K36		DFHP7106YA	BOTH SLDES TAPE	2
K37		DFHP7140ZA	DOUBLE SIDE TAPE CPU	1
K41		DFHP7220ZB	PAD COVER TAPE	1
K42		DFHP7221YA	PAD SHEET	1
K43		DFHR3416ZA	SPACER CU	3
K44		DFHR3A37ZB	SPEAKER RING	1
K45		DFHR3A39ZA	SPEAKER BOX	1
K46		DFHR3A78ZA	LCD INSULATOR	2
K47		DFHR3A88ZA	KB PLATE SHEET	1
K48		DFHR3C25ZA	USB SHEET	1
K49		DFHR3A95ZA	INVERTER TAPE	1
K50		DFHR3B19ZA	HINGE BACKUP SHEET	1
K51		DFHR3B22ZA	BOTTOM BACKUP SHEET	3
K53		DFHR3C13ZA	RJ CABLE SHEET	1
K54		DFHR3C33YA	LCD CABEL FIX SHEET	1

K55	DFKE0772ZA-0	ANTENNA COVER-L	1
K56	DFKE0877ZA-0	HINGE COVER L	1
K57	DFKE0878ZA-0	HINGE COVER R	1
K59	DFQT6342ZA	DIMM COVER SHEET T5	1
K60	DFMY3231ZA	DIMM HEAT SHEET	1
K61	DFMY0432ZA	DIMM THERMAL SPONGE	1
K63	DFKE0783YA-0	SIDE COVER-R	1
K64	DFKF0274ZA-0	LCD FRONT WAN	1
K67	DFKM0523ZA-0	LCD REAR WAN	1
K68	DFKM8172UA-0	TOP CASE ASSY	1
K69	DFMD1203ZA	LCD HOOK WAN	1
K70	DFMD3121ZA	MDC PLATE	1
K71	DFMD4057ZA	KB HOOK F999	2
K72	DFMD7A52ZA	KB PLATE	1
K74	DFMX0635ZB	EDGE SHEET	1
K75	DFMX1155ZA	INVERTER BOX	1
K76	DFMX1160ZA	PCMCIA-MAIN SHEET	1
K77	DFMX1184ZA	SW CABLE SHEET	2
K78	DFMX1262ZA	MAIN PWB SHEET	1
K79	DFMY0399ZA	MCH RUBBER	1
K80	DFMY0421ZA	HEAT SHEET KB LARGE	1
K81	DFMY3191YA	HEAT SPREADER TOP	1
K82	DFMY3192ZA	HEAT SPLEADER BOTTOM	1
K83	DFMY3206ZA	MEMORY SHEET TOP	1
K84	DFMY3208ZA	WLAN SHEET	1
K85	DFMY3230ZA	MEMORY HEAT SHEET	1
K87	DFUD0040ZA	LATCH SPRING	1
K89	DFQT0045ZA	ENERGY STAR LABEL	1
K90	DFQT0046ZA	VISTA CAPABLE LABEL	1
K91	DFQT9983ZA	CENTRINO SOLO LABEL	1
K1001	DFGX0430ZA-0	BOTTOM HEAT SHEET	1
K1002	DFGX0467ZA-0	HDD COVER HEAT SHEET WAN	1
K1003	DFGX0475ZA	CABLE BLIND SHEET	1
K1004	DFHG1810ZA-0	PEN HOLDER	1
K1005	DFHG1822ZA	LCD SIDE DAMPER TP	4
K1010	DFHG1847ZA	TP CABLE FIX CUSHION	1
K1011	DFHG1848ZA	PEN FIX CUSHION	1
K1013	DFHG1935ZA	HDD CASE WAN	1
K1014	DFHG1943ZA	LCD SIDE CUSHION	1
K1015	DFHG1944ZA	LCD REAR CUSHION	2
K1016	DFHG1948ZA	LCD DAMPER A	1
K1017	DFHG1953ZA	LCD BATT RUBBER WAN	2
K1018	DFHG1965ZA	MAGNET SPACER	1
K1019	DFHP7223ZA	PEN HOLDER TAPE	1
K1020	DFHP7268ZA	PAD BUTTON TAPE	1
K1021	DFHR3B98ZA	HDD FPC SHEET	1
K1022	DFHR3C01ZA	TAPE TP	1
K1023	DFHR3C34ZA	TP CABEL FIX SHEET	1
K1024	DFHR3C44ZA	HOLDER BOTTOM SHEET	1
K1025	DFHR3C48ZA	PEN FIX SHEET	1
K1026	DFHR3E85ZA	EDGE PROTECTION SHEET A	1
K1027	DFHR3E89ZA	LINE HOLD SHEET(WM)	1

K1028	DFHR3E92ZA	LINE HOLD SHEET A	2
K1029	DFHR5484ZA	CLAMP	2
K1030	DFHR8526ZA	CABLE FIXED SHEET	2
K1031	DFKE0815ZA-0	DIMM COVER LIGHT	1
K1035	DFKE0879ZA-0	SIMM COVER WAN	1
K1036	DFKE0884ZA-0	HDD COVER WAN	1
K1038	DFKF0275ZB-0	ANTENNA COVER	1
K1039	DFKF8166XA-0	BOTTOM CASE ASSY	1
K1039-1	DFHG371ZA-1	FOOT RUBBER	3
K1040	DFKH1020ZA-0	HANDY STRAP WAN	1
K1041	DFMD1191YA	HANDY STRAP ANGLE	2
K1042	DFMX0904ZA	DIMM CN SHEET	1
K1043	DFMX1251ZA	BOTTOM CABLE SHEET	1
K1046	 DFGT1206ZA	BOTTOM SHEET USA	1
K1047	 DFGT1207ZA	BOTTOM SHEET USA1	1
K1048	DFHE0463ZA	EMI SHEET 3	1
K1049	DFHE0862ZA	FILM IMPEDOR	1
K1050	DFHE1035ZA	WWAN EMI SHEET	1
K1051	DFHP7272ZA	WWAN TAPE	1
K1052	DFHR3154ZA	LCD CABLE TAPE	1
K1053	DFHR3F84ZA	LINE HOLD SHEET LCD	1
K1054	DFQX3998XA	OVERLAMINATE-SMALL	1
N1	DFHE5025XA	SCREW	17
N2	DFHE5035ZB	SCREW	2
N4	DRQT2+G6FKL	SCREW	1
N5	DXHM0039ZA	SCREW	9
N6	DXHM0056ZA	SCREW	1
N7	DXHM0057ZA	SCREW	7
N8	DXQT2+D25FNL	SCREW	5
N9	DXQT2+D4FNL	SCREW	1
N10	DXQT2+E10FNL	SCREW	1
N11	DXQT2+E12FNL	SCREW	4
N12	DXQT2+E6FNL	SCREW	5
N13	DXQT26+D5FNL	SCREW	2
N14	DXQT26+D8FCL	SCREW	6
N15	XSB2+4FNL	SCREW	1
N1001	DRHM0076ZA	SCREW	2
N1002	DRHM0108ZA	SCREW	2
N1003	K1YE50000022	IO PIN	2
S1001	TPD-X0033A	PET TAPE (19mmx50M/roll)	
S1002	TPD-X0034A	PET TAPE (10mmx50M/roll)	

Replacement Parts List

Note: Important Safety Notice

Components identified by  mark have special characteristics important for safety.

When replacing any of these components use only manufacturer's specified parts.

CF-T5LWETZBM (06-10-27)

REF. NO and AREA	PART NO.	DESCRIPTION	Q'TY
MAIN PCB			
C 3 C 13 C 15 C 29 C 33 C 34 C 37 C 41	F1J0J226A051	CAPACITOR, 6.3V, 22 μ F	8
C 5 C 60 C 61 C 69 C 89 C 185	EEFCX0D221R	CAPACITOR, 2V, 220 μ F	6
C 9 C 10 C 14 C 18 C 22 C 27 C 50 C 51 C 52 C 57 C 64 C 65 C 66 C 68 C 71 C 85 C 90 C 92 C 95 C 96 C 99 C 100 C 101 C 102 C 105 C 106 C 107 C 108 C 111 C 112 C 114 C 115 C 118 C 119 C 127 C 128 C 134	F1G1C104A042	CAPACITOR, 16V, 0.1 μ F	146

C 135
C 136
C 137
C 142
C 143
C 144
C 145
C 146
C 147
C 148
C 168
C 169
C 171
C 175
C 177
C 178
C 180
C 182
C 183
C 187
C 188
C 189
C 190
C 191
C 192
C 193
C 194
C 195
C 196
C 197
C 198
C 199
C 200
C 201
C 202
C 203
C 204
C 205
C 207
C 208
C 209
C 217
C 219
C 221
C 222
C 228
C 257
C 258
C 259
C 260
C 262
C 275
C 283
C 289
C 290
C 291
C 292
C 293
C 294
C 295

C 296				
C 298				
C 305				
C 310				
C 311				
C 313				
C 314				
C 315				
C 316				
C 317				
C 318				
C 319				
C 321				
C 323				
C 326				
C 328				
C 332				
C 347				
C 351				
C 358				
C 364				
C 375				
C 377				
C 378				
C 379				
C 383				
C 384				
C 386				
C 392				
C 393				
C 394				
C 406				
C 413				
C 420				
C 430				
C 431				
C 434				
C 435				
C 436				
C 437				
C 438				
C 442				
C 445				
C 604				
C 609				
C 639				
C 641				
C 674				
C 717				
C 45		F1J0J106A016	CAPACITOR, 6.3V, 10 μ F	27
C 48				
C 58				
C 59				
C 62				
C 63				
C 70				
C 72				
C 74				
C 87				
C 93				

C 167 C 176 C 206 C 280 C 297 C 303 C 304 C 325 C 339 C 368 C 395 C 441 C 446 C 447 C 668 C 695				
C 46 C 151 C 152 C 153 C 154 C 174 C 179 C 218 C 230 C 231 C 272 C 277 C 308 C 312 C 340 C 352 C 401 C 432 C 602 C 605 C 692		F1G1E103A062	CAPACITOR, 25V, 0.01 μ F	21
C 49		F1G1H222A496	CAPACITOR, 50V, 2200pF	1
C 53 C 54 C 165 C 166 C 337 C 342 C 343 C 344 C 345		F1G1A104A014	CAPACITOR, 10V, 0.1 μ F	9
C 55 C 56 C 67 C 78 C 79 C 94 C 97 C 98 C 103 C 104 C 109 C 110 C 113		F1H1A1050015	CAPACITOR, 10V, 1 μ F	38

C 116				
C 117				
C 130				
C 131				
C 132				
C 133				
C 138				
C 139				
C 140				
C 141				
C 172				
C 173				
C 184				
C 186				
C 214				
C 216				
C 301				
C 322				
C 338				
C 346				
C 390				
C 399				
C 606				
C 694				
C 702				
C 73		F1G1A474A018	CAPACITOR, 10V, 0.47 μ F	4
C 76				
C 88				
C 91				
C 77		F1J0J4750019	CAPACITOR, 6.3V, 4.7 μ F	11
C 80				
C 149				
C 150				
C 279				
C 330				
C 341				
C 370				
C 372				
C 373				
C 374				
C 81		F1H0J1050022	CAPACITOR, 6.3V, 1 μ F	11
C 82				
C 83				
C 84				
C 86				
C 129				
C 155				
C 156				
C 157				
C 158				
C 391				
C 120		F1G1H3R3A543	CAPACITOR, 50V, 3.3pF	2
C 121				
C 213		F1G1H3R0A543	CAPACITOR, 50V, 3pF	2
C 215				
C 159		F1G1H220A542	CAPACITOR, 50V, 22pF	8
C 160				
C 620				
C 623				
C 628				

C 667				
C 683				
C 686				
C 181		EEFSX0D331ER	CAPACITOR, 2V, 330µF	5
C 676				
C 698				
C 708				
C 709				
C 210		F1G1H100A544	CAPACITOR, 50V, 10pF	8
C 211				
C 212				
C 404				
C 415				
C 416				
C 418				
C 419				
C 223		EEFUD0J151ER	CAPACITOR, 6.3V, 150µF	1
C 224		EEFCX0J101R	CAPACITOR, 6.3V, 100µF	3
C 611				
C 612				
C 225		F1G1H102A496	CAPACITOR, 50V, 1000pF	32
C 229				
C 266				
C 267				
C 268				
C 269				
C 270				
C 271				
C 273				
C 274				
C 276				
C 278				
C 360				
C 361				
C 387				
C 388				
C 389				
C 403				
C 405				
C 443				
C 619				
C 622				
C 626				
C 644				
C 647				
C 663				
C 665				
C 670				
C 682				
C 689				
C 714				
C 716				
C 701		F1G1H152A496	CAPACITOR, 50V, 1500pF	1
C 226		F1G1H330A542	CAPACITOR, 50V, 33pF	9
C 227				
C 281				
C 282				
C 284				
C 285				
C 286				

C 287				
C 288				
C 263		F1J1A1050021	CAPACITOR, 10V, 1 μ F	1
C 264		F1G0J224A001	CAPACITOR, 6.3V, 0.22 μ F	7
C 265				
C 333				
C 334				
C 335				
C 336				
C 366				
C 306		F1G1H1010005	CAPACITOR, 50V, 100pF	8
C 307				
C 362				
C 363				
C 385				
C 615				
C 664				
C 691				
C 320		F1G1H5R0A543	CAPACITOR, 50V, 5pF	2
C 324				
C 329		F1L3D102A003	CAPACITOR, 2000V, 1000pF	1
C 354		F1L0J107A016	CAPACITOR, 6.3V, 100 μ F	2
C 356				
C 367		F1G1H471A496	CAPACITOR, 50V, 470pF	2
C 439				
C 400		F1G1A683A014	CAPACITOR, 10V, 0.068 μ F	1
C 411		F1G1H470A542	CAPACITOR, 50V, 47pF	2
C 412				
C 601		F1H1H104A731	CAPACITOR, 50V, 0.1 μ F	1
C 603		F1L1E106A017	CAPACITOR, 25V, 10 μ F	9
C 629				
C 651				
C 652				
C 658				
C 673				
C 677				
C 693				
C 705				
C 607		F1J1E105A009	CAPACITOR, 25V, 1 μ F	1
C 608		F1J1E104A081	CAPACITOR, 25V, 0.1 μ F	1
C 614		F1K1E1060001	CAPACITOR, 25V, 10 μ F	4
C 706				
C 707				
C 722				
C 616		F1H1H104A748	CAPACITOR, 50V, 0.1 μ F	16
C 618				
C 625				
C 659				
C 662				
C 669				
C 678				
C 681				
C 688				
C 697				
C 699				
C 700				
C 703				
C 704				
C 719				
C 732				

C 617 C 627		F1H1H103A748	CAPACITOR, 50V, 0.01µF	2
C 621 C 648 C 661 C 666 C 672 C 679 C 684 C 685		F1G1H221A495	CAPACITOR, 50V, 220pF	8
C 624 C 649 C 687 C 718 C 733		F1J0J475A009	CAPACITOR, 6.3V, 4.7µF	5
C 630 C 675		EEFCX0G151R	CAPACITOR, 2V, 150µF	2
C 637 C 638 C 640		F1G1C473A004	CAPACITOR, 16V, 0.047µF	3
C 642		F1G1H121A495	CAPACITOR, 50V, 120pF	1
C 643		F1G1H561A496	CAPACITOR, 50V, 560pF	1
C 645		F1H1H1830001	CAPACITOR, 50V, 0.018µF	1
C 646		F1G1H182A496	CAPACITOR, 50V, 1800pF	1
C 650		F1J1H224A533	CAPACITOR, 50V, 0.22µF	1
C 657 C 696		EEFCD0D101ER	CAPACITOR, 2V, 100µF	2
C 660 C 690		F1H1H472A748	CAPACITOR, 50V, 4700pF	2
C 671 C 680		F1H1H182A748	CAPACITOR, 50V, 1800pF	2
C 715		F1G1H331A496	CAPACITOR, 50V, 330pF	1
C 720		F1H1H222A748	CAPACITOA, 50V, 2200pF	1
CF 1		D4CC1103A038	THERMISTOR	1
CN 2		K1MMH2B00003	CONNECTOR	1
CN 3 CN 26		K1KA02BA0014	CONNECTOR	2
CN 4		K1MN45AA0044	CONNECTOR	1
CN 10		K1KA05BA0014	CONNECTOR	1
CN 11		K1KB30AA0049	CONNECTOR	1
CN 12		K1FB315BA003	CONNECTOR	1
CN 13		K1NA09E00076	CONNECTOR	1
CN 14		K1NA68E00096	CONNECTOR	1
CN 15		K1MY26BA0001	CONNECTOR	1
CN 16		K1KA08BA0014	CONNECTOR	1
CN 18		K1KB12A00099	CONNECTOR	1
CN 19		K1MY52BA0190	CONNECTOR	1
CN 21		K1MN12BA0134	CONNECTOR	1
CN 22		K1FY150BA007	CONNECTOR	1
CN 23		K1KA20BA0114	CONNECTOR	1
CN 24		K1KA05BA0181	CONNECTOR	1
CN 28		K1KA12BA0014	CONNECTOR	1
CN 600		K1KA02B00247	CONNECTOR	1
CN 601		K1KA10B00233	CONNECTOR	1
D 1 D 2 D 3 D 22		MA2J72900L	DIODE RECTIFIER	4
D 4		MA3J741E0L	DIODE	1
D 5		B0KB00000044	DIODE	2

D 6				
D 7		B0ADDH000004	DIODE	6
D 8				
D 9				
D 601				
D 602				
D 604				
D 10		B3ABB0000164	LED	4
D 11				
D 12				
D 13				
D 15		B3AKB0000008	LED	1
D 16		B3ACB0000020	LED	2
D 21				
D 20		B3ABB0000274	LED	1
D 23		MA2S111-TX	DIODE	3
D 619				
D 621				
D 600		B0JCPD000023	DIODE	3
D 603				
D 636				
D 605		MAZ81200ML	DIODE	1
D 606		MAZ81800ML	ZENER DIODE	1
D 607		MA3S132E0L	DIODE RECTIFIER	2
D 622				
D 608		B0JCQD000001	DIODE	1
D 609		B0JCMD000014	SHOTKEY BARRIER DIODE	7
D 611				
D 624				
D 626				
D 627				
D 629				
D 630				
D 610		B0JDAE000004	DIODE	2
D 625				
D 612		MAZ80510ML	DIODE	6
D 613				
D 614				
D 615				
D 617				
D 618				
D 616		MAZ80620ML	DIODE	1
D 620		B2ABAM000002	THYRISTOR	1
D 623		DEDRB081L20	DIODE	1
D 628		B0JCCE000008	DIODE	2
D 639				
F 1	⚠	K5H2021A0003	FUSE, 2A	2
F 7	⚠			
F 8	⚠	K5H202Z00005	FUSE, 2A	1
F 9	⚠	K5H402Z00003	FUSE, 4A	1
F 600	⚠	K5H632300002	FUSE, 6.3A	1
IC 1		C2GBC0000312	IC, CPU	1
IC 2		C1CB00002432	IC, CHIP SET	1
IC 3		C1DB00001541	IC, CHIP SET	1
IC 4		C0DBZY00017	IC	1
IC 5		C3ABSG000029	IC, DDR2 SDRAM	8
IC 6				
IC 7				
IC 8				
IC 9				

IC 10				
IC 11				
IC 12				
IC 13		C0JBZZ000388	IC, CLOCK GENERATOR	1
IC 16		C0CBCBG00008	IC, REGULATOR	1
IC 17		C1DB00001182	IC, LAN CONTROLLER	1
IC 18		C3EBCG000100	IC, EEPROM	1
IC 19		C0CBCBC00137	IC, REGURATOR	1
IC 20		C1CB00002540	IC, TEMPERATURE SENSOR IC	1
IC 21		C0DBZYY00026	IC, USB POWER SW	3
IC 22				
IC 71				
IC 27		C0JBAR000515	IC, Q-SWITCH	2
IC 29				
IC 28		C0DBZYY00016	IC	1
IC 30		C1CB00002449	IC, AUDIO CODEC	1
IC 31		C0CBCBC00181	IC	1
IC 33		C1CB00002268	IC, SECURITY CHIP	1
IC 34		C3FBLY000024	IC, SPI FLASH MEMORY	1
IC 36		C2CBJA000003	IC, MICON	1
IC 37		C0EBE0000460	IC	2
IC 38				
IC 42		C0JBAB000619	IC, GATE LOGIC	1
IC 43		C0JBAA000344	IC, GATE LOGIC	6
IC 44				
IC 54				
IC 55				
IC 61				
IC 614				
IC 45		C0JBAE000302	IC, LOGIC	2
IC 51				
IC 46		C0JBAA000346	IC, LOGIC	4
IC 47				
IC 48				
IC 49				
IC 50		C1CB00002295	IC	1
IC 52		C0JBAB000616	IC, LOGIC	3
IC 603				
IC 604				
IC 53		C0ABBA000093	OP AMP	2
IC 601				
IC 58		C0DBZYY00019	IC, POWER MANAGEMENT SWITCH	1
IC 64		C0JBAZ002422	IC, FET SWITCH	2
IC 70				
IC 69		C1BB00001025	IC, AUDIO AMP	1
IC 600		C0DBALH00003	IC	4
IC 602				
IC 609				
IC 611				
IC 605		C0DBAYY00155	IC, DC/DC	1
IC 606		C0DBEFH00002	IC, REGULATOR	1
IC 607		C0DBDJH00009	IC, LINEAR	1
IC 608		C0ABZA000047	IC, AMP	1
IC 610		C0EBE0000333	IC	1
JK 1		K2HC1YYB0027	JACK	2
JK 2				
L 1		G1C1R0MA0076	INDUCTOR	2
L 3				
L 2		G1C91NM00001	INDUCTOR	1
L 4		J0JJC0000021	INDUCTOR	1

L 5 L 7 L 26 L 54		J0JHC0000074	INDUCTOR	4
L 13 L 14 L 27 L 28 L 29 L 30 L 31 L 32 L 33		J0JCC0000186	INDUCTOR	9
L 17 L 18 L 19		J0JBC0000072	INDUCTOR, FILTER	3
L 21 L 22		J0ZZB0000080	INDUCTOR, COMMON MODE FILTER	2
L 25		DDB5Z024E-L	INDUCTOR	1
L 34 L 35 L 36 L 37		DDB5Z024C-L	INDUCTOR, FERRITE PARTS	4
L 38 L 39 L 40 L 41 L 42 L 43		DDB5Z021C-Y	INDUCTOR	6
L 55 L 56		DDB5Z032A-L	INDUCTOR, FERRITE PARTS	2
L 57		J0MAB0000116	INDUCTOR, EMI FILTER	1
L 601 L 606 L 607		G1C4R7MA0022	INDUCTOR	3
L 608		G1A160H00001	INDUCTOR	1
L 602		DDAZS100MT3T	INDUCTOR	1
L 605		G1C220MA0077	INDUCTOR	1
L 604		G1C2R8MA0022	INDUCTOR, COIL	1
L 603		G1CR88ZA0140	INDUCTOR, COIL	1
L 600		J0JKC0000007	INDUCTOR	1
PA 1 PA 2 PA 3		D4FB1R100009	SWITCH	3
Q 1 Q 41 Q 51 Q 52		B1GDCFNN0031	TRANSISTOR	4
Q 2 Q 4 Q 43 Q 50 Q 604 Q 606 Q 645 Q 646 Q 651 Q 652 Q 653 Q 657		B1GBCFJN0037	TRANSISTOR	12

Q 6 Q 7 Q 27 Q 647 Q 654 Q 662 Q 663 Q 666		B1CFGD000023	TRANSISTOR	8
Q 10 Q 36 Q 38 Q 628 Q 631 Q 632 Q 634 Q 635 Q 636		XP0421300L	TRANSISTOR	9
Q 11 Q 40 Q 630 Q 633		B1DHDC000028	TRANSISTOR	4
Q 28 Q 35 Q 37		B1MBDCA00004	TRANSISTOR	3
Q 29 Q 54 Q 601 Q 603 Q 605 Q 611 Q 624		B1GBCFNN0042	TRANSISTOR	7
Q 46 Q 47 Q 600		XP0421400L	TRANSISTOR	3
Q 48		B1GFCFEN0003	TRANSISTOR	1
Q 53		B1GBCFNL0017	TRANSISTOR	1
Q 602		B1CFMC000008	FET	1
Q 607 Q 610		B1CHRD000001	FET	2
Q 608 Q 655		B1DHFD000015	TRANSISTOR	2
Q 612 Q 613		B1CFRD000014	FET	2
Q 614 Q 643		B1CFGD000003	FET	2
Q 615 Q 644		B1MBEDA00017	FET	2
Q 627		B1DHFB000003	TRANSISTOR	1
Q 637 Q 641 Q 642 Q 650 Q 656		B1DBGD000006	FET	5
Q 638		B1DFGD000032	TRANSISTOR	1
Q 648		B1MBEDA00018	FET	1
Q 649		B1CFRD000013	FET	1
R 1 R 57 R 61 R 62		ERJ2GEJ102X	RESISTOR, 1/16W, 1KΩ	15

R 187 R 218 R 235 R 272 R 273 R 392 R 393 R 462 R 479 R 480 R 492				
R 2 R 5 R 6 R 9		ERJ2GEJ510X	RESISTOR, 1/16W, 51Ω	4
R 13 R 14 R 65 R 203 R 237 R 332 R 350 R 362 R 391 R 478 R 486 R 502 R 504 R 508 R 518 R 608 R 609 R 667 R 668 R 673 R 676 R 677 R 678 R 679 R 697		ERJ2GEJ101X	RESISTOR, 1/16W, 100Ω	25
R 15 R 696		ERJ2RKF1001X	RESISTOR, 1/16W, 1KΩ	2
R 16		ERJ2RKF2001X	RESISTOR, 1/16W, 2KΩ	1
R 18		ERJ2RKF51R0X	RESISTOR, 1/16W, 51Ω	1
R 19 R 21		ERJ2RKF27R4X	RESISTOR, 1/16W, 27.4Ω	2
R 20 R 22 R 32 R 33		ERJ2RKF54R9X	RESISTOR, 1/16W, 54.9Ω	4
R 24		ERJ2GEJ680X	RESISTOR, 1/16W, 68Ω	1
R 25 R 27 R 28		ERJ2GEJ560X	RESISTOR, 1/16W, 56Ω	3
R 26		ERJ3GEYJ201V	RESISTOR, 1/16W, 200Ω	1
R 30 R 34 R 35 R 86 R 228		ERJ2RKF24R9X	RESISTOR, 1/16W, 24.9Ω	5

R 31 R 354 R 610 R 614 R 616 R 747		ERJ2GEJ562X	RESISTOR, 1/16W, 5.6KΩ	6
R 37 R 39		ERJ2RKF2210X	RESISTOR, 1/16W, 221Ω	2
R 38 R 40 R 42		ERJ2RKF1000X	RESISTOR, 1/16W, 100Ω	3
R 41		ERJ2RKF2000X	RESISTOR, 1/16W, 200Ω	1
R 63		ERJ2RKF1002X	RESISTOR, 1/16W, 10KΩ	1
R 66 R 319 R 320 R 325 R 326 R 394 R 395		ERJ2GEJ222X	RESISTOR, 1/16W, 2.2KΩ	7
R 74 R 75		ERJ2RKF80R6X	RESISTOR, 1/16W, 80.6Ω	2
R 78 R 170 R 196 R 197 R 220 R 268 R 457		D1H81034A024	RESISTOR ARRAY	7
R 384		D1H84734A024	RESISTOR ARRAY	1
R 79 R 80		ERJ2GEJ390X	RESISTOR, 1/16W, 39Ω	2
R 81 R 759		ERJ2RKF1501X	RESISTOR, 1/16W, 1.5KΩ	2
R 82		ERJ2RKF2550X	RESISTOR, 1/16W, 255Ω	1
R 83 R 84 R 85 R 327 R 328 R 329 R 488 R 489 R 490		ERJ2RKF1500X	RESISTOR, 1/16W, 150Ω	9
R 91		ERJ3GEJ220V	RESISTOR, 1/16W, 22Ω	1
R 93 R 173 R 234 R 242 R 243 R 264 R 282 R 313 R 314 R 335 R 336 R 338 R 348 R 349 R 358		ERJ2GEJ103X	RESISTOR, 1/16W, 10KΩ	47

R 372				
R 374				
R 396				
R 402				
R 413				
R 421				
R 422				
R 426				
R 428				
R 437				
R 444				
R 447				
R 448				
R 452				
R 453				
R 484				
R 519				
R 520				
R 521				
R 619				
R 639				
R 644				
R 688				
R 704				
R 708				
R 712				
R 713				
R 728				
R 733				
R 734				
R 743				
R 817				
R 95		ERJ2GEJ201X	RESISTOR, 1/16W, 200Ω	4
R 96				
R 97				
R 98				
R 99		D1HG1008A001	RESISTOR ARRAY	8
R 100				
R 101				
R 102				
R 127				
R 128				
R 129				
R 130				
R 103		ERJ2GEJ100X	RESISTOR, 1/16W, 10Ω	37
R 104				
R 105				
R 106				
R 107				
R 108				
R 109				
R 110				
R 111				
R 112				
R 113				
R 114				
R 115				
R 116				
R 117				
R 118				

R 119				
R 120				
R 121				
R 122				
R 123				
R 124				
R 125				
R 126				
R 341				
R 636				
R 637				
R 649				
R 650				
R 705				
R 706				
R 716				
R 717				
R 725				
R 726				
R 737				
R 738				
R 131		ERJ2GE0R00X	RESISTOR, 1/16W, 0Ω	68
R 132				
R 133				
R 134				
R 135				
R 136				
R 137				
R 138				
R 139				
R 140				
R 141				
R 142				
R 143				
R 144				
R 145				
R 146				
R 147				
R 148				
R 149				
R 150				
R 151				
R 152				
R 153				
R 154				
R 155				
R 156				
R 189				
R 192				
R 224				
R 226				
R 233				
R 238				
R 239				
R 240				
R 247				
R 252				
R 257				
R 316				
R 317				

R 333				
R 346				
R 386				
R 399				
R 406				
R 407				
R 430				
R 431				
R 449				
R 450				
R 458				
R 472				
R 481				
R 485				
R 487				
R 491				
R 501				
R 600				
R 692				
R 703				
R 719				
R 760				
R 761				
R 763				
R 768				
R 773				
R 774				
R 785				
R 787				
R 157		D1HA56080001	RESISTOR ARRAY	7
R 158				
R 159				
R 160				
R 161				
R 162				
R 163				
R 165		ERJ2GEJ104X	RESISTOR, 1/16W, 100KΩ	31
R 171				
R 215				
R 248				
R 249				
R 250				
R 308				
R 311				
R 331				
R 334				
R 337				
R 342				
R 343				
R 352				
R 383				
R 454				
R 459				
R 460				
R 461				
R 475				
R 476				
R 503				
R 506				
R 611				

R 621				
R 623				
R 624				
R 625				
R 664				
R 666				
R 672				
R 166		ERJ3GEYJ1R0V	RESISTOR, 1/16W, 1Ω	8
R 167				
R 168				
R 169				
R 245				
R 699				
R 762				
R 769				
R 174		ERJ2GEJ472X	RESISTOR, 1/16W, 4.7KΩ	2
R 754				
R 179		ERJ2GEJ330X	RESISTOR, 1/16W, 33Ω	20
R 181				
R 183				
R 184				
R 185				
R 186				
R 191				
R 217				
R 271				
R 368				
R 404				
R 419				
R 424				
R 493				
R 494				
R 495				
R 496				
R 497				
R 498				
R 499				
R 193		ERJ2GEJ473X	RESISTOR, 1/16W, 47KΩ	15
R 195				
R 270				
R 292				
R 347				
R 400				
R 620				
R 634				
R 684				
R 378				
R 388				
R 390				
R 505				
R 515				
R 517				
R 216		D1H84724A024	RESISTOR ARRAY	1
R 219		DEARA8AJ103M	RESISTOR ARRAY	7
R 265				
R 266				
R 267				
R 455				
R 456				
R 513				

R 221 R 222 R 443 R 473		ERJ2GEJ470X	RESISTOR, 1/16W, 47Ω	4
R 229		ERJ2RKF22R6X	RESISTOR, 1/16W, 22.6Ω	1
R 246		ERJ3GEYJ121V	RESISTOR, 1/16W, 120Ω	1
R 255 R 280 R 355		ERJ2GEJ334X	RESISTOR, 1/16W, 330KΩ	3
R 258		ERJ2GEJ203X	RESISTOR, 1/16W, 20KΩ	1
R 259		ERJ2GEJ106X	RESISTOR, 1/16W, 10MΩ	1
R 260 R 361 R 397 R 398 R 622 R 669		ERJ2GEJ105X	RESISTOR, 1/16W, 1MΩ	6
R 274 R 275		ERJ2GEJ363X	RESISTOR, 1/16W, 36KΩ	2
R 305		ERJ2RKF3922X	RESISTOR, 1/16W, 39.2KΩ	1
R 330		ERJ6GEY0R00V	RESISTOR, 1/10W, 0Ω	1
R 339		ERJ2RKF2002X	RESISTOR, 1/16W, 20KΩ	1
R 353		ERJ2RHD562X	RESISTOR, 1/16W, 5.6KΩ	1
R 356 R 357 R 359 R 360		ERJ2RKF49R9X	RESISTOR, 1/16W, 49.9Ω	4
R 367		EXBV8V750JV	RESISTOR ARRAY	1
R 369		ERJ2RKF5101X	RESISTOR, 1/16W, 5.1KΩ	1
R 376 R 377		ERJ3GEYJ330V	RESISTOR, 1/16W, 33Ω	2
R 382 R 385 R 423 R 767 R 775 R 776		ERJ3GEY0R00V	RESISTOR, 1/16W, 0Ω	6
R 401 R 757		ERJ2GEJ471X	RESISTOR, 1/16W, 470Ω	2
R 415 R 471		ERJ2GEJ561X	RESISTOR, 1/16W, 560Ω	2
R 446		ERJ2RKF3901X	RESISTOR, 1/16W, 3.9KΩ	1
R 451 R 603 R 607		ERJ2RHD103X	RESISTOR, 1/16W, 10KΩ	3
R 465 R 467 R 469 R 470		J0JBC0000107	RESISTOR, 150mA, 0.8Ω	4
R 474 R 483		ERJ6GEYJ101V	RESISTOR, 1/10W, 100Ω	2
R 507		ERJ2GEJ273X	RESISTOR, 1/16W, 27KΩ	1
R 522 R 740		ERJ2GEJ221X	RESISTOR, 1/16W, 220Ω	2
R 523 R 524		ERJ3GEYJ151V	RESISTOR, 1/16W, 150Ω	2
R 525		ERJ2GEJ331X	RESISTOR, 1/16W, 330Ω	1
R 601		ERJ3GEYJ562V	RESISTOR, 1/16W, 5.6KΩ	1
R 602		D1ZZ00000046	RESISTOR, 1W, 5mΩ	1
R 604		D1BDR4700001	RESISTOR, 1/8W, 0.47Ω	1

R 605 R 613		ERJ2RHD104X	RESISTOR, 1/16W, 100K Ω	2
R 606 R 612		ERJ2RKD154X	RESISTOR, 1/16W, 150K Ω	2
R 615 R 617		ERJ1TYJ331U	RESISTOR, 1W, 330 Ω	2
R 618		ERJ3GEYJ3R3V	RESISTOR, 1/16W, 3.3 Ω	1
R 628		D1BDR1000002	RESISTOR, 1/8W, 0.1 Ω	1
R 626 R 627		RL1220SR15F	RESISTOR, 1/8W, 0.15 Ω	2
R 629 R 630 R 631 R 651 R 652 R 701 R 702 R 723 R 724 R 741 R 742 R 755 R 756 R 777		D1BDR0220001	RESISTOR, 1/8W, 0.022 Ω	14
R 632		ERJ2RKF1102X	RESISTOR, 1/16W, 11K Ω	1
R 633		ERJ2RKF1302X	RESISTOR, 1/16W, 13K Ω	1
R 635 R 718 R 720 R 739 R 745 R 772		ERJ2GEJ474X	RESISTOR, 1/16W, 470K Ω	6
R 638 R 707 R 727 R 816		ERJ2GEJ153X	RESISTOR, 1/16W, 15K Ω	4
R 640 R 709 R 729 R 818		ERJ3GEYJ100V	RESISTOR, 1/16W, 10 Ω	4
R 641 R 648		ERA3YEB622V	RESISTOR, 1/16W, 6.2K Ω	2
R 642 R 751 R 752		ERA3YKB104V	RESISTOR, 1/16W, 100K Ω	3
R 643 R 731		ERA3YEB203V	RESISTOR, 1/16W, 20K Ω	2
R 645		ERJ2GEJ333X	RESISTOR, 1/16W, 33K Ω	1
R 646 R 753 R 793		ERA3YEB333V	RESISTOR, 1/16W, 33K Ω	3
R 647		ERA3YEB123V	RESISTOR, 1/16W, 12K Ω	1
R 663		ERJ2GEJ684X	RESISTOR, 1/16W, 680K Ω	1
R 665		ERJ2GEJ225X	RESISTOR, 1/16W, 2.2M Ω	1
R 680		ERJ2GEJ223X	RESISTOR, 1/16W, 22K Ω	1
R 681 R 821		ERJ6GEYJ122V	RESISTOR, 1/10W, 1.2K Ω	2
R 682 R 683		ERJ6GEYJ222V	RESISTOR, 1/10W, 2.2K Ω	2
R 687		ERJ2RKF1603X	RESISTOR, 1/16W, 160K Ω	1

R 689		ERJ2RKF1003X	RESISTOR, 1/16W, 100KΩ	1
R 690		ERJ2RKF1800X	RESISTOR, 1/16W, 180Ω	1
R 693		ERJ2RKF1801X	RESISTOR, 1/16W, 1.80KΩ	1
R 694		ERJ2RKF4701X	RESISTOR, 1/16W, 4.7KΩ	2
R 710				
R 695		ERJ2RKF4221X	RESISTOR, 1/16W, 4.22KΩ	1
R 700		D1ZZ00000093	RESISTOR, 1W, 1mΩ	1
R 711		ERJ2RKF1502X	RESISTOR, 1/16W, 15KΩ	2
R 735				
R 714		ERJ2RKF5102X	RESISTOR, 1/16W, 51KΩ	1
R 715		ERJ2RKF2402X	RESISTOR, 1/16W, 24KΩ	1
R 721		D1BDR0470002	RESISTOR, 1/8W, 0.047Ω	1
R 730		ERA3YEB621V	RESISTOR, 1/16W, 620Ω	1
R 732		ERA3YEB243V	RESISTOR, 1/16W, 24KΩ	2
R 792				
R 736		ERJ2RHD123X	RESISTOR, 1/16W, 12KΩ	1
R 744		ERJ2RKD114X	RESISTOR, 1/16W, 110KΩ	1
R 746		ERJ2RHD3652X	RESISTOR, 1/16W, 36.5KΩ	1
R 748		ERJ2GEJ154X	RESISTOR, 1/16W, 150KΩ	1
R 749		ERJ2RHD302X	RESISTOR, 1/16W, 3KΩ	2
R 750				
R 758		ERJ2RKF4702X	RESISTOR, 1/16W, 47KΩ	1
R 766		ERJ3GEYJ101V	RESISTOR, 1/16W, 100Ω	1
R 771		ERJ2RKF6801X	RESISTOR, 1/16W, 6.80KΩ	1
R 790		ERJ3RED754V	RESISTOR, 1/16W, 750KΩ	1
R 791		ERA3YKB513V	RESISTOR, 1/16W, 51KΩ	1
SW 5		K0ZZ00000617	SWITCH	1
SW 6		ESD165225	SLIDE SWITCH	1
SW 7		K0D112B00071	SLIDE SWITCH	1
SW 8		EVQPLDA15	SWITCH	2
SW 9				
T 1		G5BYC0000015	TRANCE	1
X 1		H0J143500058	OSCILLATOR, 14.318MHz	1
X 2		H0J327200115	OSCILLATOR, 32.768KHz	1
X 4		H0J250500067	OSCILLATOR, 25MHz	1
X 5		H2D800400015	OSCILLATOR, 8MHz	1
ZA 1		DRHM0114ZA	SCREW	1
ZA 2		DRHM0113ZA	SCREW	1
ZA 3		K1YGZZ000060	SPACER	2
ZA 4				
USB PCB				
C 1051		EEFUD0J151ER	CAPACITOR, 6.3V, 150μF	2
C 1052				
CN 1051		K1KA12BA0014	CONNECTOR	1
CN 1052		K1FB104B0062	USB CONNECTOR	2
CN 1053				
D 1051		B0KB00000044	DIODE	2
D 1052				
L 1053		J0JHC0000074	INDUCTOR	4
L 1054				
L 1055				
L 1056				
L 1051		J0MAB0000116	INDUCTOR, EMI FILTER	2
L 1052				
TS PCB				
C 1105		F1G1H681A450	CAPACITOR, 50V, 680pF	4
C 1106				
C 1107				
C 1108				
C 1109		F1G1C104A042	CAPACITOR, 16V, 0.1μF	3

C 1112				
C 1113				
C 1110		F1G1E223A062	CAPACITOR, 25V, 0.022µF	1
C 1101		F1G1E472A062	CAPACITOR, 25V, 4700pF	4
C 1102				
C 1103				
C 1104				
C 1111		F1G1H102A450	CAPACITOR, 50V, 1000pF	1
C 1114		F1G0J224A001	CAPACITOR, 6.3V, 0.22µF	1
C 1115		F1J0J475A009	CAPACITOR, 6.3V, 4.7µF	1
C 1116		F1J0J106A024	CAPACITOR, 6.3V, 10µF	1
CN 1101		K1KA05BA0014	CONNECTOR	1
CN 1102		K1MN04B00078	CONNECTOR	1
IC 1101		C0EBE0000460	IC	1
IC 1102		C1CB00002515	IC, TOUCHPANEL CONTROLLER	1
IC 1103		C0CBCAC00312	IC, REGULATOR	1
Q 1101		XP0431400L	TRANSISTOR	2
Q 1102				
Q 1103		UNR9113J0L	TRANSISTOR	1
Q 1104		UNR9213J0L	TRANSISTOR	1
R 1101		ERJ2GEJ473X	RESISTOR, 1/16W, 47KΩ	2
R 1107				
R 1104		ERJ2GEJ102X	RESISTOR, 1/16W, 1KΩ	12
R 1106				
R 1110				
R 1111				
R 1112				
R 1113				
R 1118				
R 1120				
R 1121				
R 1122				
R 1123				
R 1130				
R 1114		ERJ2GEJ822X	RESISTOR, 1/16W, 8.2KΩ	4
R 1115				
R 1116				
R 1117				
R 1124		DEARA8AJ473M	RESISTOR ARRAY	1
R 1125		ERJ2GEJ270X	RESISTOR, 1/16W, 27Ω	2
R 1126				
R 1127		ERJ2GEJ152X	RESISTOR, 1/16W, 1.5KΩ	1
R 1129		ERJ2GE0R00X	RESISTOR, 1/16W, 0Ω	1
R 1109		ERJ2GEJ273X	RESISTOR, 1/16W, 27KΩ	1
R 1119		ERJ2GEJ512X	RESISTOR, 1/16W, 5.1KΩ	1
X 1101		H2D600400005	OSCILLATOR, 6MHz	1
WWAN PCB				
C 1501		F1J0J106A016	CAPACITOR, 6.3V, 10µF	3
C 1523				
C 1527				
C 1502		F1G1C104A042	CAPACITOR, 16V, 0.1µF	5
C 1503				
C 1504				
C 1516				
C 1528				
C 1505		F1G1H101A451	CAPACITOR, 50V, 100pF	1
C 1520		F1G1H221A495	CAPACITOR, 50V, 220pF	1
C 1524		EEFCX0G151R	CAPACITOR, 2V, 150µF	2
C 1525				
CN 1501		K1KA12BA0014	CONNECTOR	1

CN 1502		K1MY52BA0190	MINI-PCI-EXP CONNECTOR	1
CN 1503		K1NA08E00007	CONNECTOR	1
D 1520		DEDRB081L20	DIODE	1
IC 1520		C0DBAYY00204	IC, DC/DC CONVERTER	1
L 1520		G1C2R7MA0273	INDUCTOR, COIL	1
Q 1520		B1CFGD000023	TRANSISTOR	1
Q 1522		B1DHFD000015	TRANSISTOR	1
Q 1521		B1GBCFNN0042	TRANSISTOR	1
R 1502 R 1504		ERJ2GEJ101X	RESISTOR, 1/16W, 100Ω	2
R 1503 R 1505		ERJ2GE0R00X	RESISTOR, 1/16W, 0Ω	2
R 1521 R 1523		ERJ2GEJ103X	RESISTOR, 1/16W, 10KΩ	2
R 1522		D1BDR0330001	RESISTOR, 1/8W, 0.033Ω	1
R 1524		ERJ2RKF1002X	RESISTOR, 1/16W, 10KΩ	1
R 1525		ERA3YEB303V	RESISTOR, 1/16W, 30KΩ	1
R 1526		ERJ2RKF1001X	RESISTOR, 1/16W, 1KΩ	1
R 1527		D1BDR0470002	RESISTOR, 1/8W, 0.047Ω	1
SW 1501		K0D211A00015	DIP SWITCH	1
ZA 1501 ZA 1502		K1YGZZ000060	SPACER	2